

MODEL 212
as of model year 2014

- 1 Engine air intake duct
- 2 Cold air intake
- 3 Carrier
- 4 Screw
- 5 Headlamp
- 6 Bolts
- 7 Screw
- 8 Screw

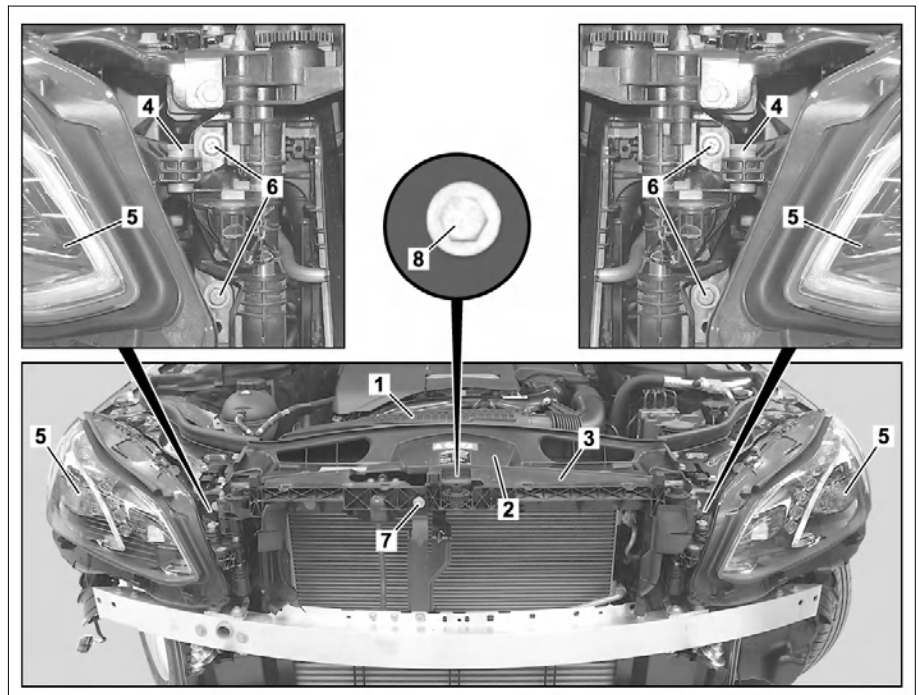

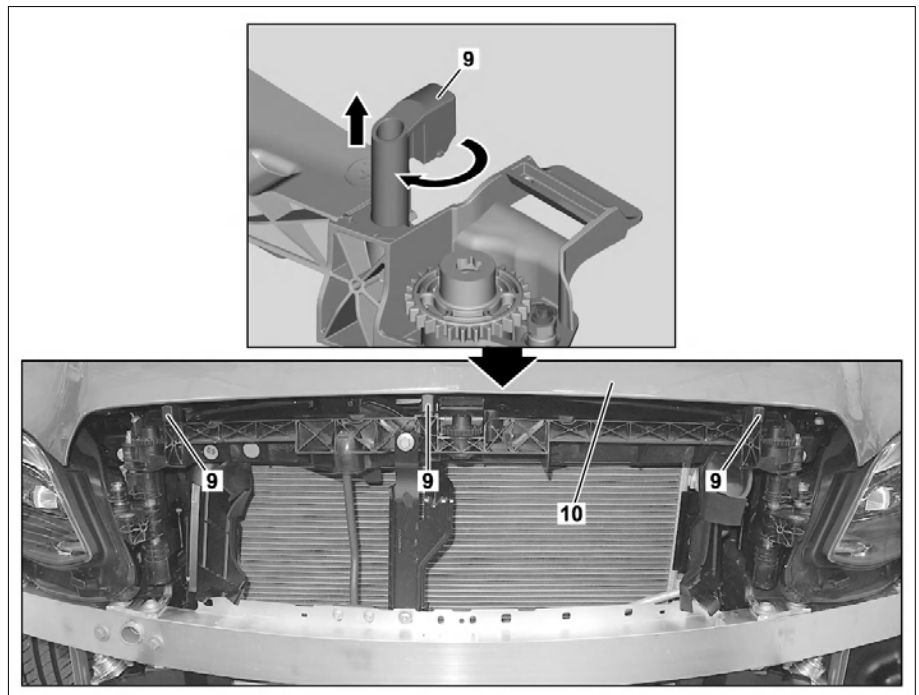

P88.20-4010-06

- 9 Adjusting aid
- 10 Engine hood



P88.20-4011-06

	Remove		
1	Remove front bumper		AR88.20-P-2000EWM
2	Remove engine air intake duct (1)		
3	Detach cold air intake (2) and fold toward rear		
4	Detach headlamp (5)	<p>i To do this, unscrew bolts (4).</p> <p>i Detach headlamp (5) until screws (6) are accessible.</p>	AR82.10-P-4730EWM
5	Remove screw/bolts (6)		
6	Remove screw/bolt (7)		

7	Loosen bolt (8)		
8	Remove carrier (3)		
	Install		
9	Install carrier (3)	 Only position bolts (6, 7, 8), do not tighten.	
10	Pull adjustment aid (9) upward and turn clockwise 180° (arrow) until adjustment aid (9) arrests		
11	Close engine hood (10)		
12	Lift carrier (3) until adjustment aid (9) makes contact with engine hood (10)		
13	Tighten bolts (6, 7, 8)		
14	Open engine hood (10)		
15	Turn adjustment back (9) and arrest in carrier (3)		
16	Install cold air intake (2)		
17	Install engine intake air duct (1)		
18	Fasten headlamp (5)		AR82.10-P-4730EWM
19	Install front bumper		AR88.20-P-2000EWM