

MODEL 212
with CODE 475 (Tire pressure monitor (premium))
Schrader

Valid up to model year 2014

- A1 Instrument cluster
- A1e66 Tire pressure monitor warning lamp
- A1p13 Multifunction display
- A69/1 Left front tire pressure sensor
- A69/2 Right front tire pressure sensor
- A69/3 Left rear tire pressure sensor
- A69/4 Right rear tire pressure sensor
- B14 Outside temperature sensor
- N10/1 Front SAM control unit with fuse and relay module
- N73 Electronic ignition switch control unit
- N80 Steering column module control unit
- N88 Tire pressure monitor control unit
- N135 Steering wheel electronics
- S110 Left multifunction steering wheel button group
- S111 Right multifunction steering wheel button group
- X11/4 Diagnostic connector
- CAN B Interior CAN
- CAN D Diagnostic CAN
- CAN E Chassis CAN
- LIN E1 Steering LIN

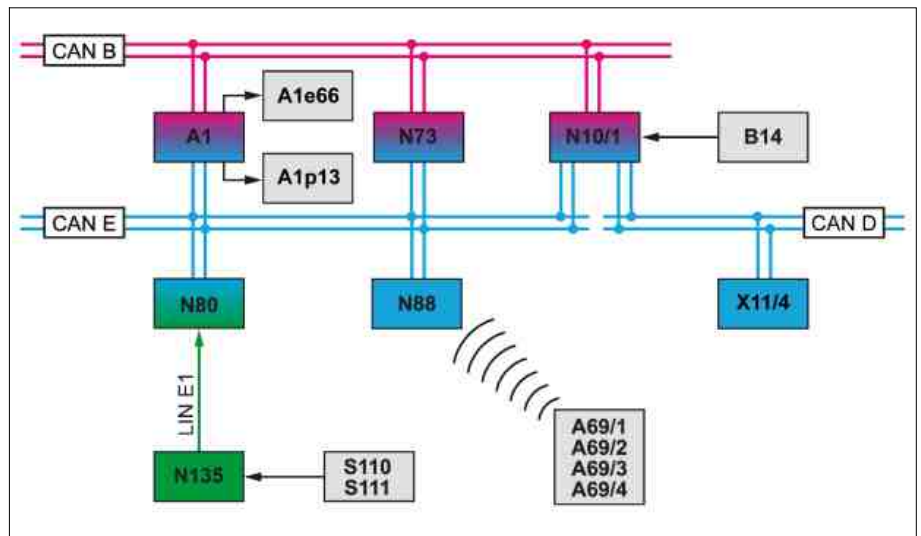

P40.15-2541-75

Valid as of model year 2014

- A1 Instrument cluster
- A1e66 Tire pressure monitor warning lamp
- A1p13 Multifunction display
- A69/1 Left front tire pressure sensor
- A69/2 Right front tire pressure sensor
- A69/3 Left rear tire pressure sensor
- A69/4 Right rear tire pressure sensor
- B14 Outside temperature sensor
- N10/1 Front SAM control unit with fuse and relay module
- N73 Electronic ignition switch control unit
- N80 Steering column module control unit
- N88 Tire pressure monitor control unit
- N135 Steering wheel electronics
- S110 Left multifunction steering wheel button group
- S111 Right multifunction steering wheel button group
- X11/4 Diagnostic connector
- CAN B Interior CAN
- CAN D Diagnostic CAN
- CAN E1 Chassis CAN 1
- CAN E2 Chassis CAN 2
- LIN E1 Steering LIN

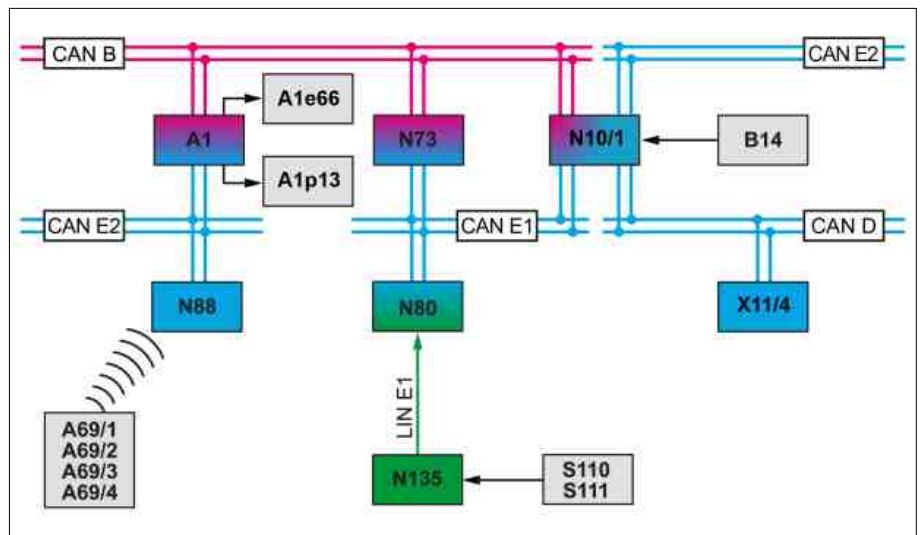

P40.15-2546-75