

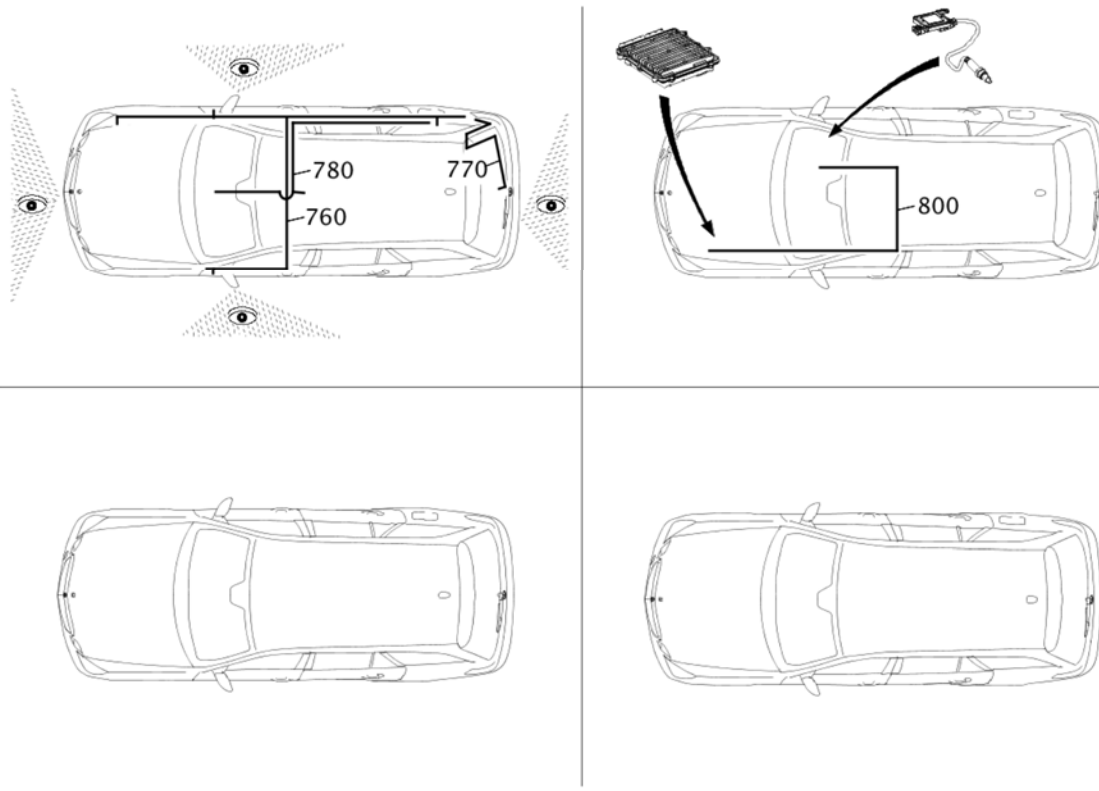



















- Parts list -

Mode	BM mode	BM overview	E 350 4MATIC
VIN/mod. des.	C212288	Catalog	D24
VIN		Group	54 ELECTRICAL EQUIPMENT AND INSTRUMENTS
Assortment class	PC		
Market		Sub-group	545 FRAME FLOOR UNIT MAIN CABLE HARNESS



Copyright 2019-10-22 Daimler AG

Image ID: drawing_B54545000650

Item	Part number	Designation/additional information	Qty
760	A 212 440 85 37 	* ELECTRICAL WIRING HARNESS 360 DEGREE VIEWING SYSTEM  Code: (804/805)+501;	1
760	A 212 440 29 58 	* ELECTRICAL WIRING HARNESS 360 DEGREE VIEWING SYSTEM  Code: (806/807/808)+501;	1
770	A 212 440 88 36 	* ELECTRICAL WIRING HARNESS 360 DEGREE VIEWING SYSTEM X8/46*5 TO B84/10*1  Code: (804/805)+501;	1
770	A 212 540 55 02 	* ELECTRICAL WIRING HARNESS 360 DEGREE VIEWING SYSTEM X8/46*5 TO B84/10*1  Code: (806/807/808)+501;	1
780	A 212 440 51 38 	* ELECTRICAL WIRING HARNESS 360 DEGREE VIEWING SYSTEM  Code: 501+(804/805)+-518;	1
780	A 212 440 94 37  	* ELECTRICAL WIRING HARNESS 360 DEGREE VIEWING SYSTEM  Code: 501+518+(804/805);	1
780	A 212 440 65 35  	* ELECTRICAL WIRING HARNESS 360 DEGREE VIEWING SYSTEM  Code: 501+518+(804/805);	1
780	A 212 440 56 59  	* ELECTRICAL WIRING HARNESS 360 DEGREE VIEWING SYSTEM  Code: 501+531+(806/807/808);	1