

Shown on injection valve for cylinder 1

- 1 Fuel distributor
 1a Connection fitting
 2 Securing clamp
 2a Pin
 2b Molding
 3 O-ring

Y62/1 Cylinder 1 injection valve

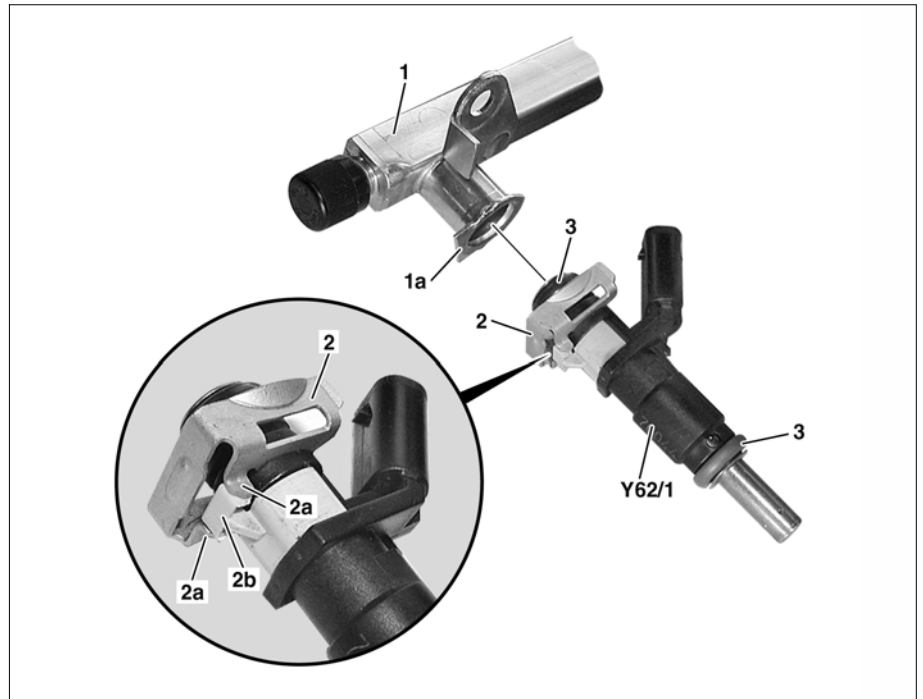

P07.03-2270-06

	Removing		
	Notes on avoiding damage through contamination and foreign objects		AH00.00-P-5000-01A
1	Switch off ignition		
2	Remove air filter housing		AR09.10-P-1150EWS
3	Remove fuel distributor (1)		AR07.03-P-1451EW
4	Pry out securing clamps (2) of injection valves (Y62/1 up to Y62/6 or Y62/8)		
5	Pull injection valves (Y62/1 to Y62/6 or Y62/8) out of fuel distributor (1)	Intercept escaping fuel with an absorbent rag.	
	Install		
6	Replace O-rings (3)		
7	Slide securing clamps (2) onto injection valves (Y62/1 to Y62/6 or Y62/8)	Slide on so that journals (2a) of securing clamps (2) surround formed sections (2b) on the injection valves (Y62/1 to Y62/6 or Y62/8).	
8	Apply lubricating paste to O-rings (3)	Lubricant paste	*BR00.45-Z-1002-06A
9	Slide injection valves (Y62/1 to Y62/6 or Y62/8) into fuel distributor (1) in the correct position	The shapes of securing clamps (2) and connection fittings (1a) determine the installation position of the injection valves (Y62/1 to Y62/6 or Y62/8). The safety clips (2) must latch in audibly.	
10	Install in the reverse order		
11	Risk of accident caused by vehicle starting off by itself when engine is running. Risk of injury caused by contusions and burns during starting procedure or when working near the engine as it is running Carry out an engine test run and check fuel system for leaks	Secure vehicle to prevent it from moving by itself. Wear closed and snug-fitting work clothes. Do not touch hot or rotating parts.	AS00.00-Z-0005-01A

Repair materials

Number	Designation	Order number
BR00.45-Z-1002-06A	Lubricating paste, rubber parts 2.5 kg, DB supply specification 6867.00	A 000 989 01 60