

172 589 00 63 00

Adapter plate

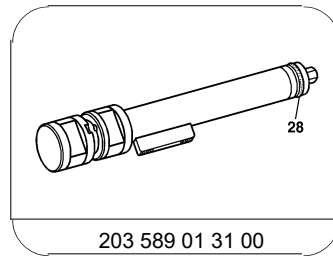

203 589 01 31 00

Tensioning device

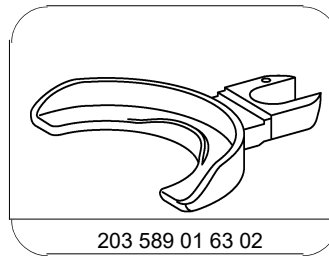

203 589 01 63 02

Clamping plate

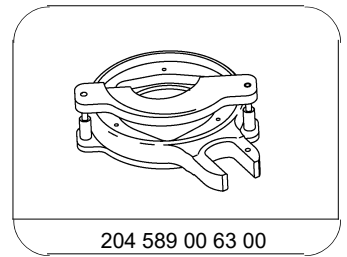

204 589 00 63 00

Clamping plate

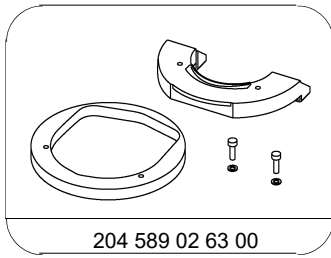

204 589 02 63 00

Adapter plate

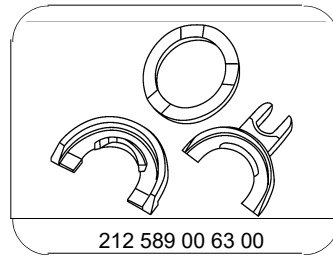

212 589 00 63 00

Adapter plate

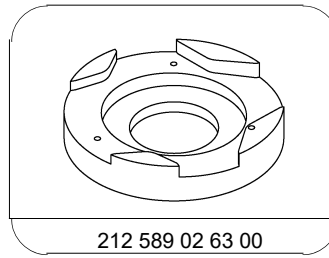

212 589 02 63 00

Adapter plate

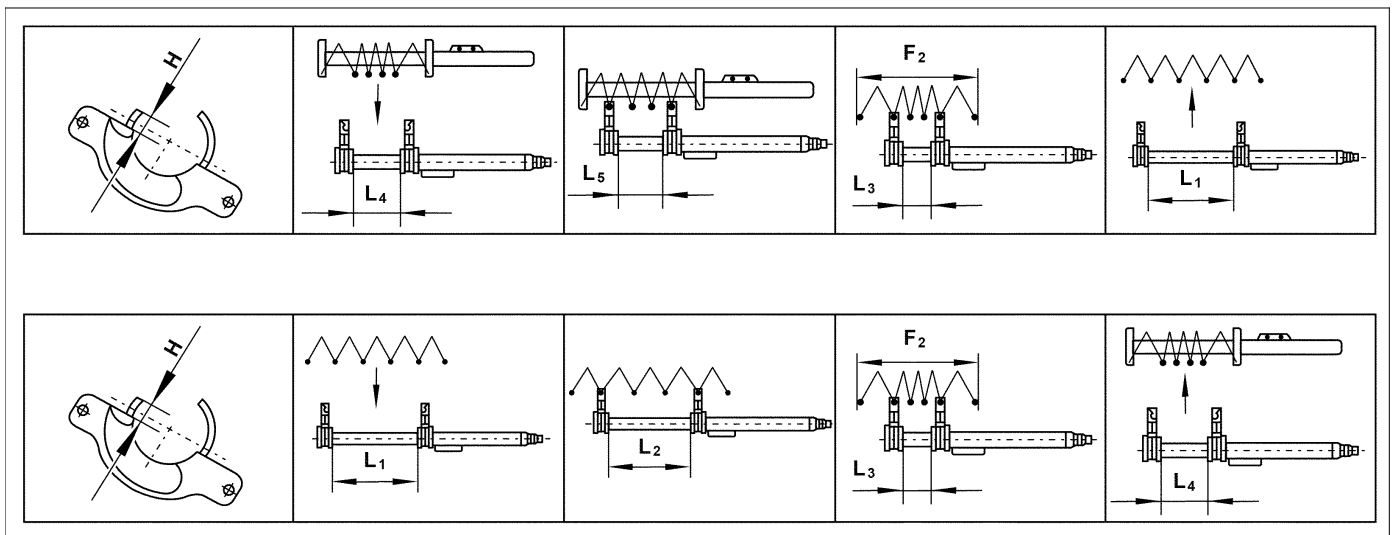

P32.25-2241-08

Positioning dimensions for tensioning device:

Model 172 without code (483) ADVANCED AGILITY package

$H = 5 \text{ mm}$
 $L1 = 260 - 280 \text{ mm}$
 $L2 = 240 - 260 \text{ mm}$

$L3 = 45 - 50 \text{ mm}$
 $L4 = 190 - 200 \text{ mm}$
 $L5 = 140 - 150 \text{ mm}$

Model 172 with code (483) ADVANCED AGILITY package

$H = 5 \text{ mm}$
 $L1 = 230 - 240 \text{ mm}$
 $L2 = 210 - 220 \text{ mm}$

$L3 = 45 - 48 \text{ mm}$
 $L4 = 185 \text{ mm}$
 $L5 = 135 - 140 \text{ mm}$

Model 204.0/2/3, 207, 204.9 with code (486) Sports suspension

$H = 10 \text{ mm}$
 $L1 = 270 - 285 \text{ mm}$
 $L2 = 230 - 250 \text{ mm}$

$L3 = 55 \text{ mm}$
 $L4 = 160 - 165 \text{ mm}$
 $L5 = 150 \text{ mm}$

Model 204.9 without code (486) Sports suspension

$H = 40 \text{ mm}$
 $L1 = 250 - 270 \text{ mm}$
 $L2 = 225 - 230 \text{ mm}$

$L3 = 60 \text{ mm}$
 $L4 = 160 - 175 \text{ mm}$
 $L5 = 130 - 140 \text{ mm}$

Model 212 with code (482) Suspension for increased ground clearance

$H = 30 \text{ mm}$
 $L1 = 285 - 290 \text{ mm}$
 $L2 = 250 - 270 \text{ mm}$

$L3 = 70 \text{ mm}$
 $L4 = 175 - 185 \text{ mm}$
 $L5 = 150 - 160 \text{ mm}$

Model 212 with code (485) Comfort suspension

$H = 30 \text{ mm}$
 $L1 = 290 \text{ mm}$
 $L2 = 245 - 260 \text{ mm}$

$L3 = 80 \text{ mm}$
 $L4 = 185 - 200 \text{ mm}$
 $L5 = 160 - 170 \text{ mm}$

Model 212 with code (677) AVANTGARDE suspension, model 218 without code (486) Sports suspension and without code (488) Steel/air suspension

H = 30 mm
L1 = 290 mm
L2 = 230 - 240 mm

L3 = 55 mm
L4 = 160 - 170 mm
L5 = 130 - 145 mm



Model 212, 218 with code (486) Sports suspension or code (488) Steel/air suspension

H = 10 mm
L1 = 210 - 220 mm
L2 = 180 - 195 mm

L3 = 50 mm
L4 = 155 - 160 mm
L5 = 115 - 130 mm



Dismantle front spring

i  The clamping devices must be mounted to prevent unintended twisting of the front spring.



- 1  Mount clamping device part 1 (01) and  spacer ring (03) on upper  clamping plate (04) with bolts (3).

i Assembly position for clamping device:

Model 172:

 The clamping device part 1 (01) must be positioned in bore 11 and 19 relative to the upper  clamping plate (04).

Model 204, 207, 212, 218:

 The clamping device part 1 (01) must be positioned in bore 7 and 15 relative to the upper  clamping plate (04).

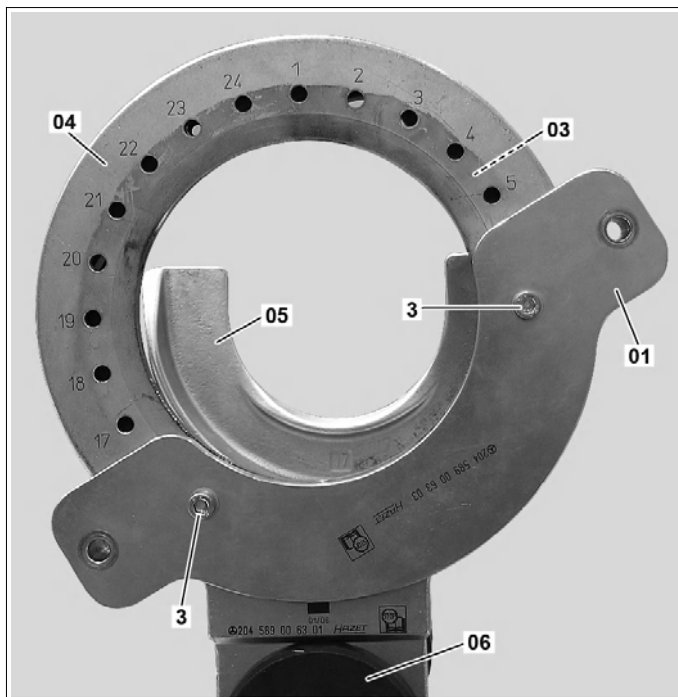

P32.25-2242-12

i Assignment of  spacer ring (03):

Model 172:

-  Use spacer ring (03) from 172 589 00 63 00.

Model 204.0/2/3, 207:

-  Use spacer ring (03) from 204 589 00 63 00.

Model 204.9:



-  Use spacer ring (03) from 204 589 02 63 00.

Model 212 with code (482) Suspension for greater ground clearance or code (485) Comfort suspension or code (677) AVANTGARDE suspension, model 218 without code (486) Sports suspension and without code (488) Steel/air suspension:

-  Use spacer ring (03) from 212 589 00 63 00.

Model 212, 218 with code (486) Sports suspension or code (488) Steel/air suspension:

-  Use spacer ring (03) from 212 589 02 63 00.

- 2  Mount lower clamping plate (05) and move tensioning device  (06) into assembly position.

i Assignment of  clamping plate (05):

Model 172, 204, 207, 218,

-  Use clamping plate (05) from 203 589 01 63 02.

For model 204.9 also use  protective insert 204 589 02 63 02 from 204 589 02 63 00.

Model 212, with code (486) Sports suspension or code (488) Steel/air suspension or code (677) AVANTGARDE suspension:



-  Use clamping plate (05) from 203 589 01 63 02.

Model 212 with code (482) Suspension for greater ground clearance or code (485) Comfort suspension:

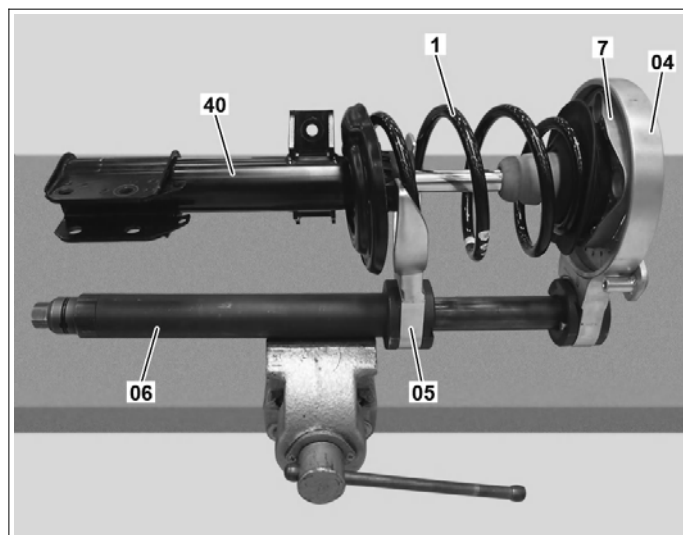

-  Use clamping plate (05) 212 589 00 63 00.



P32.25-2243-11

- 3 Insert suspension strut (40) into preassembled upper clamping plate (04)  and lower  clamping plate (05).

i Insert suspension strut (40) by turning between upper and lower  clamping plate (04, 05).

- 4 Align head bearing (7) with  spacer ring (03) and move  tensioning device (06) into insert position "L4".

i The head bearing (7) only fits in one position in the  spacer ring (03).

- 5 Mount clamping device part 2 (02) on clamping device part 1 (01) with clamp bolts (2).

Tighten clamp bolts (2) by hand until the clamping device part 2 (02) abuts the front spring (1).

Assignment of clamp bolts (2):

Model 204.0/2/3, 207,
model 212 with code (482) Suspension for greater ground clearance or code (485) Comfort suspension or code (677) AVANTGARDE suspension,
model 218 without code (486) Sports suspension or without code (488) Steel/air suspension:

- Use clamp bolts (2) from 204 589 00 63 00.

Model 172, 204.9

model 212, 218 with code (486) Sports suspension or code (488) Steel/air suspension:

- Use clamp bolts (2) from 204 589 02 63 00.

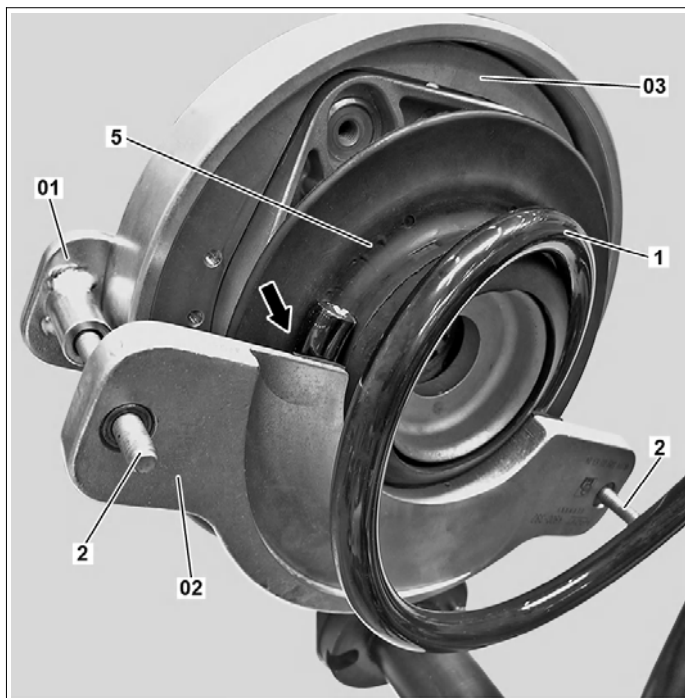

P32.25-2244-12

- 6 Twist front spring (1) so that the start of the spring coil reaches position "H" (arrow).

- 7 Clamp front spring (1) until the clamping position "L5" is reached.

- 9 Clamp front spring (1) with tensioning device (06) until the clamping position "L3" is reached.

- 10 Detach nut from piston rod.

Counterhold piston rod with Torx TX50

- 11 Move out suspension strut (6).

- 12 Move tensioning device (06) into removal position "L1".

- 13 Remove front spring (1) and head bearing (7).

- 8 Tighten clamping bolts (2).

Always observe the guide value of 5 Nm. Otherwise, the thrust bearing (5) may be damaged or the front spring (1) may twist during clamping.

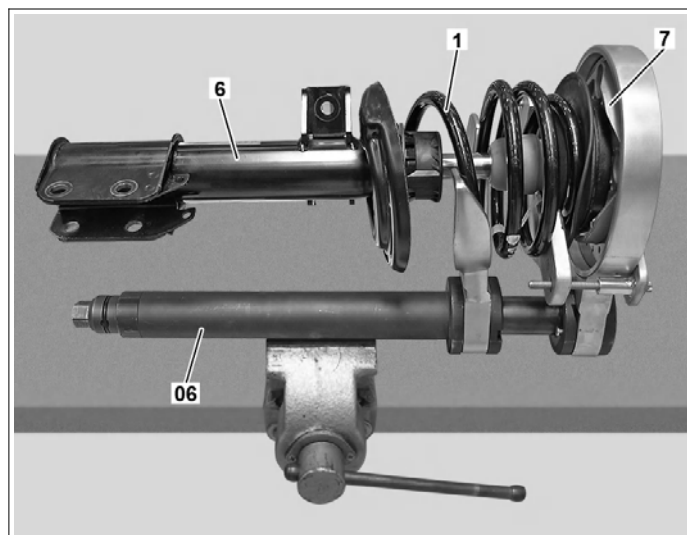

P32.25-2245-11

Mount front spring (1)

The clamping devices must be mounted to prevent unintended twisting of the front spring (1).

- 14 Mount clamping device part 1 (01) and spacer ring (03) on upper clamping plate (04) with bolts.

Assembly position for clamping device:

Model 172:

The clamping device part 1 (01) must be positioned in bore 11 and 19 relative to the upper clamping plate (04).

Model 204, 207, 212, 218:

The clamping device part 1 (01) must be positioned in bore 7 and 15 relative to the upper clamping plate (04).

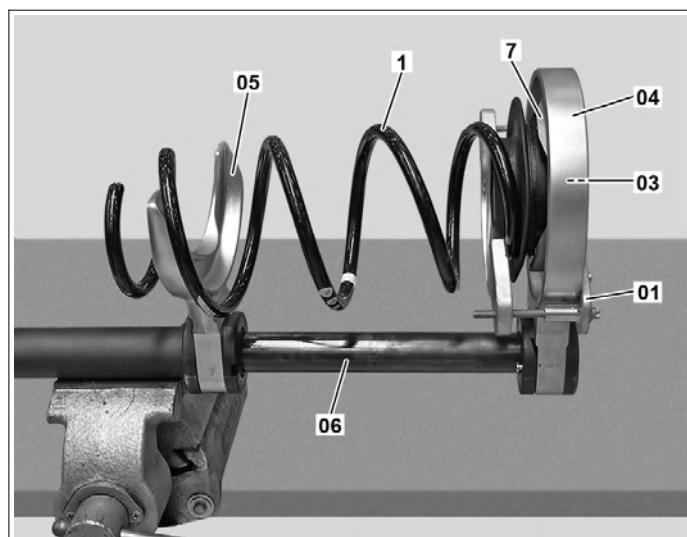

P32.25-2246-11

i Assignment of  spacer ring (03):

Model 172:

-  Use spacer ring (03) from 172 589 00 63 00.

Model 204.0/2/3, 207:

-  Use spacer ring (03) from 204 589 00 63 00.

Model 204.9:



-  Use spacer ring (03) from 204 589 02 63 00.

Model 212 with code (482) Suspension for greater ground clearance or code (485) Comfort suspension or code (677) AVANTGARDE suspension, model 218 without code (486) Sports suspension and without code (488) Steel/air suspension:

-  Use spacer ring (03) from 212 589 00 63 00.

Model 212, 218 with code (486) Sports suspension or code (488) Steel/air suspension:

-  Use spacer ring (03) from 212 589 02 63 00.

15  Mount lower clamping plate (05) and move tensioning device  (06) into assembly position.

i Assignment of  clamping plate (05):

Model 172, 204, 207, 218,

-  Use clamping plate (05) from 203 589 01 63 02.

For model 204.9 also use  protective insert 204 589 02 63 02 from 204 589 02 63 00.

Model 212, with code (486) Sports suspension or code (488) Steel/air suspension or code (677) AVANTGARDE suspension:



-  Use clamping plate (05) from 203 589 01 63 02.



Model 212 with code (482) Suspension for greater ground clearance or code (485) Comfort suspension:

-  Use clamping plate (05) 212 589 00 63 00.

16 Place head bearing (7) in  spacer ring (03).

i The head bearing (7) only fits in one position in the spacer ring (03) and must abut the upper  clamping plate (04).

18  Mount clamping device part 2 (02)  on clamping device part 1 (01) with clamp bolts (2). 

i  Tighten clamp bolts (2) by hand until the  clamping device part 2 (02) abuts the front spring (1).

i Assignment of  clamp bolts (2):

Model 204.0/2/3, 207,

model 212 with code (482) Suspension for greater ground clearance or code (485) Comfort suspension or code (677) AVANTGARDE suspension, model 218 without code (486) Sports suspension or without code (488) Steel/air suspension:

-  Use clamp bolts (2) from 204 589 00 63 00.

Model 172, 204.9

model 212, 218 with code (486) Sports suspension or code (488) Steel/air suspension:

-  Use clamp bolts (2) from 204 589 02 63 00.

17  Move tensioning device (06) into insert position "L1" and insert front spring (1).

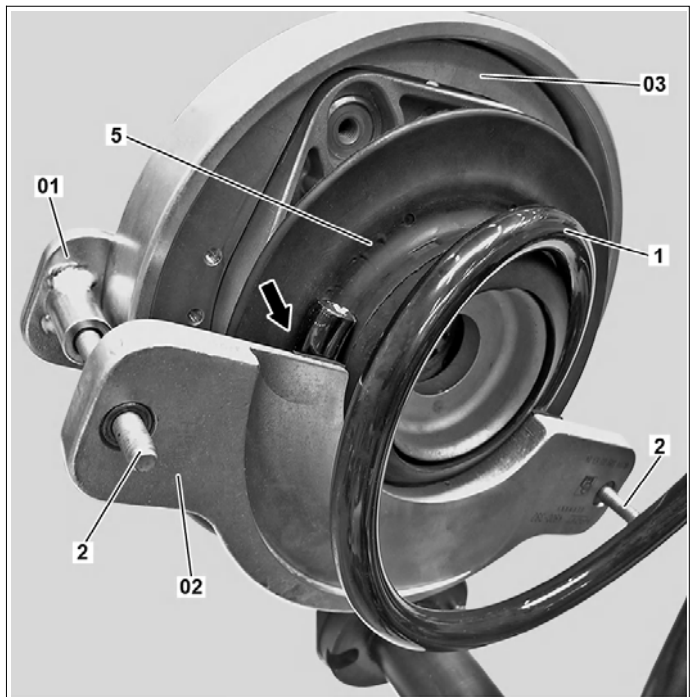

P32.25-2244-12

19 Twist front spring (1) so that the start of the spring coil reaches position "H" (arrow).

i So that the front spring (1) can be correctly applied at the thrust bearing (5), the front spring (1) may not yet be positioned in the lower  clamping plate.

20  Tighten clamp bolts (2).

i Always observe the guide value of 5 Nm. Otherwise, the thrust bearing (5) may be damaged or the front spring (1) may twist during clamping.

- 21 Position front spring (1) in the lower clamping plate (05) and move tensioning device (06) into the clamping position "L5".
- 22 Check positioning of front spring (1) in the tensioning device (06) and in the clamping plates (04, 05).
- 23 Clamp front spring (1) until the clamping position "L3" is reached.
 ⚠️ Clamp carefully. Otherwise clamping device part 2 (02) may damage the front spring (1) (arrow).



P32.25-2247-12

- 24 Insert suspension strut (6) and mount new nut on piston rod.
 ⓘ Counterhold piston rod with Torx T50
 Observe position of front spring (1) in lower spring cup (8). The end of the spring coil must abut the end stop (9) in the lower spring cup (8).
- 25 Release front spring (1) until the release position "L5" is reached.
 ⚠️ Do not release front spring (1) further. Otherwise there is a risk of damaging clamping device part 1 (01) and clamping device part 2 (02).
- 26 ⚙️ Detach clamping device part 2 (02) from clamping device part 1 (01) with clamp bolts (2).
- 27 ⚙️ Move tensioning device (06) into removal position "L4".
- 28 Detach suspension strut (40) from tensioning device (06).
 ⓘ Detach suspension strut (40) by turning out of upper and lower clamping plate (04, 05).

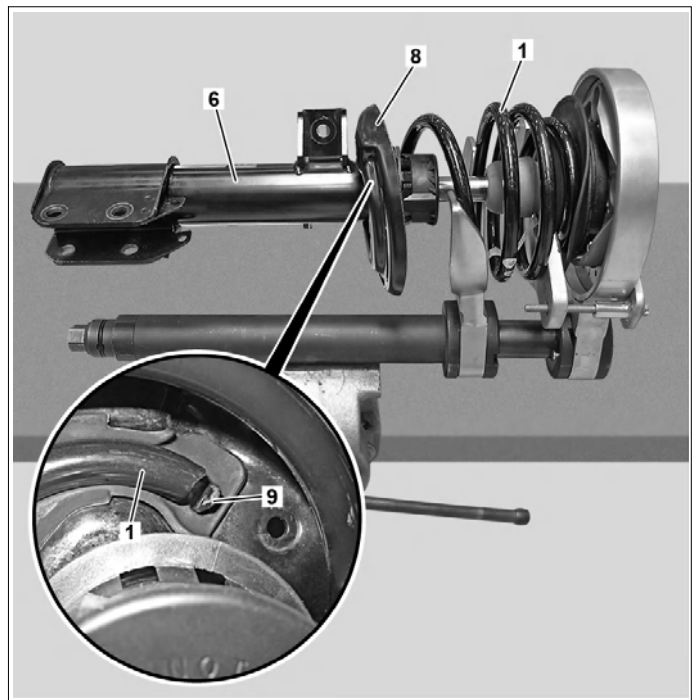

P32.25-2248-12