

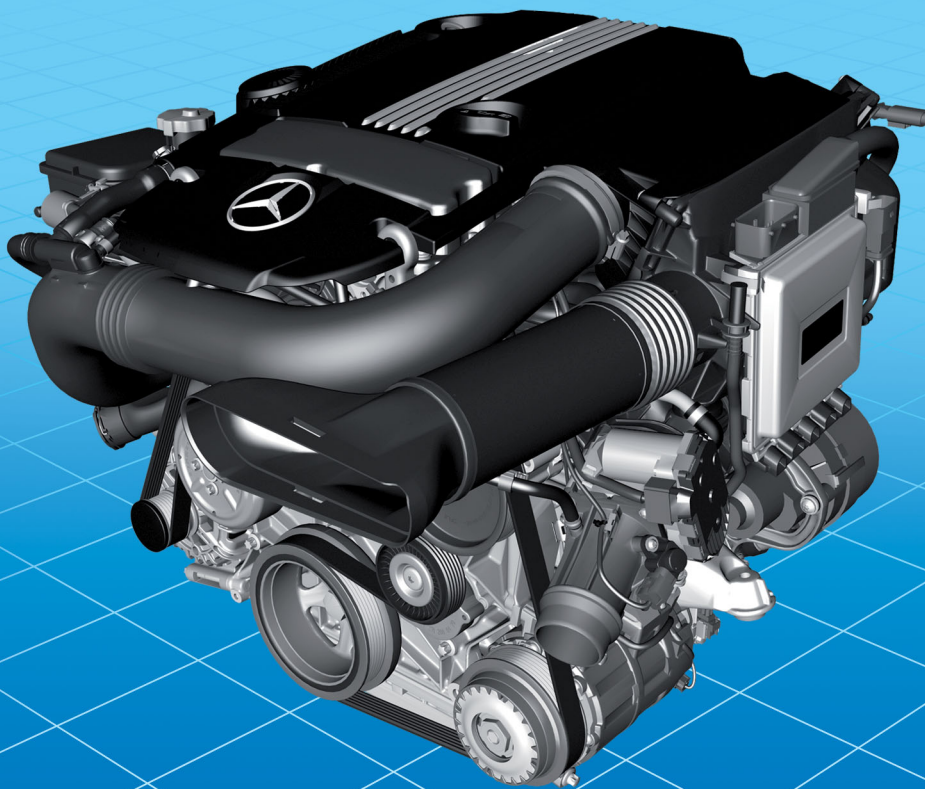

New 4-Cylinder Gasoline Engine M 271 EVO

Introduction into Service Manual

Mercedes-Benz



Introduction of the New 4-Cylinder Gasoline Engine M 271 EVO

Introduction into Service Manual

Ordering workshop information

All printed workshop information from GSP/OI, such as Introduction into Service Manuals, System Descriptions, Function Descriptions, Technology Guides and Technical Data Manuals, can be ordered as follows:

In Germany

Through our GSP/TI Shop on the Internet

Link: <http://gsp-ti-shop.de>

or alternatively

Email: customer.support@daimler.com

Phone: +49-(0)18 05 /0 10-79 79

Fax: +49-(0)18 05 /0 10-79 78

Outside Germany

Please get in touch with the contact person responsible for your market.

Product Portfolio

Comprehensive information about our full Product Portfolio can also be found at our Internet Portal.

Link: <http://aftersales.mercedes-benz.com>

Questions and suggestions

If you have any questions or suggestions concerning this product, please write to us.

Email: customer.support@daimler.com

Fax: +49-(0)18 05 /0 10-79 78

or alternatively

Address: Daimler AG

GSP/OIS

HPC R822, W002

D-70546 Stuttgart

© 2009 by Daimler AG

This document, including all its parts, is protected by copyright.

Any further processing or use requires the previous written consent of Daimler AG, Department GSP/OIS, HPC R822, W002, D-70546 Stuttgart.

This applies in particular to reproduction, distribution, alteration, translation, microfilming and storage and/or processing in electronic systems, including databases and online services.

Image no. of title image: P01.00-3188-00

Order no. of this publication: 6516 1370 02

04 / 09

Preface	5
----------------	---

Overview

Brief description	6
New features	7
Engine views	8
Engine data	9

Mechanical components

Cylinder head	10
Crankcase	12
Chain drive	14
Crank assembly	16
Belt drive	17

Fuel injection

Homogeneous direct injection	18
Fuel system	21

Forced induction

System overview	22
Boost pressure control	25
Swirl flap control	30

Exhaust aftertreatment

Lambda control	32
Secondary air injection	34

Cooling and lubrication

Engine cooling	36
Engine lubrication	40

Vehicle electronics

Motor electronics control unit	42
Ignition system	46
ECO start/stop system	47

Special tools

Engine	50
--------	----

Abbreviations	54
---------------	----

Index	55
-------	----

Dear reader,

This Introduction into Service Manual presents the changes and new features in the 4-cylinder gasoline engine M 271 EVO.

It allows you to familiarize yourself with the technical highlights of this new engine in advance of its market launch. This brochure is primarily intended to provide information for people employed in service, maintenance and repair as well as for aftersales staff. It is assumed that the reader is already familiar with the Mercedes-Benz model series and engines currently on the market.

In terms of the contents, the emphasis in this Introduction into Service Manual is on presenting new and modified components, systems, system components and their functions.

This Introduction into Service Manual aims to provide an overview of the technical innovations and an insight into the complex systems.

However, this Introduction into Service Manual is not intended as a basis for repair work or technical diagnosis. For such needs, more extensive information is available in the Workshop Information System (WIS) and in the XENTRY Diagnostics system.

WIS is updated monthly. Therefore, the information available there reflects the latest technical status of our vehicles.

The contents of this brochure are not updated. No provision is made for supplements. We will publicize modifications and new features in the relevant WIS documents. The information presented in this Introduction into Service Manual may therefore differ from the more up-to-date information found in WIS.

All the information relating to specifications, equipment and options is valid as of the copy deadline in March 2009 and may therefore differ from the current production configuration.

Daimler AG

Technical Information
and Workshop Equipment (GSP / OI)

Brief description

M 271 EVO

From September 2009 the M 271 EVO will be used in the BlueEFFICIENCY models of the C-Class and E-Class. There are three power variants: 115, 135 and 150 kW.

The development of the M 271 EVO combines the following objectives:

- Improved responsiveness due to increased power and higher torque
- Improved comfort thanks to smoother running
- Significantly lower fuel consumption and reduced CO₂ emissions
- Compliance with the Euro 5 standard

The M 271 EVO therefore combines the BlueEFFICIENCY requirements for economy and environmental compatibility with comfort and driving pleasure.

These objectives are realized by a variety of technical innovations and improvements:

- Low-noise and low-maintenance chain drive
- Camshaft adjustment
- Lanchester balancer
- Homogeneous direct injection with 140 bar injection pressure
- Fuel injectors
- Quantity-controlled fuel pump
- Turbocharger
- Lambda control
- Secondary air injection for rapid heating of the catalytic converter
- Two-disk thermostat with three-disk functionality
- Radiator shutters
- Regulated oil pump with high efficiency
- Ignition system
- ECO start / stop system



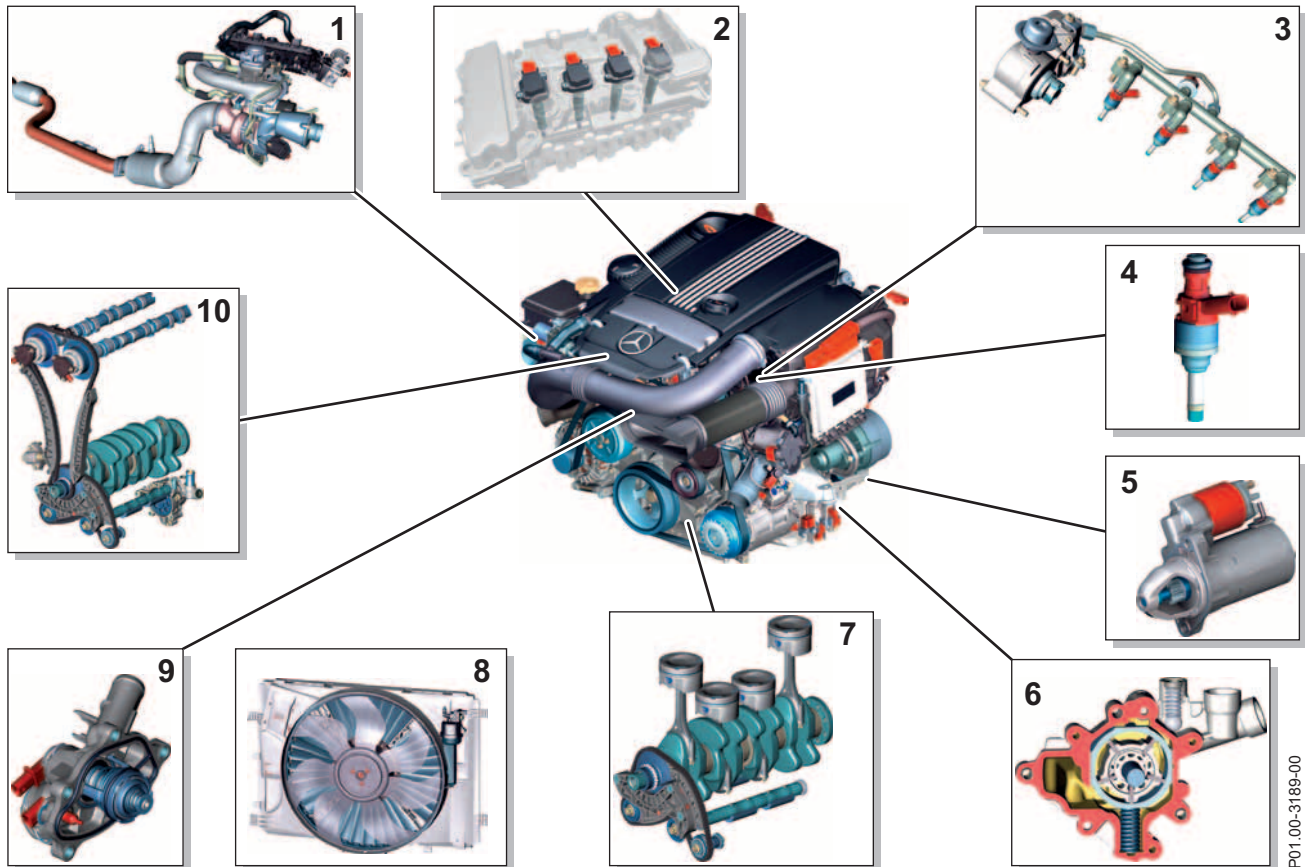

P01.00-3189-00

Overview of new features and improvements

- 1 Exhaust system with turbocharger, optimized lambda control and secondary air injection
- 2 Ignition system
- 3 Homogeneous direct injection with quantity-controlled fuel pump
- 4 Fuel injectors
- 5 ECO start/stop system
- 6 Regulated oil pump
- 7 Lanchester balancer
- 8 Radiator shutters
- 9 Two-disk thermostat with three-disk functionality
- 10 Low-noise and low-maintenance chain drive with optimized camshaft adjustment

Engine views



M 271 EVO control end

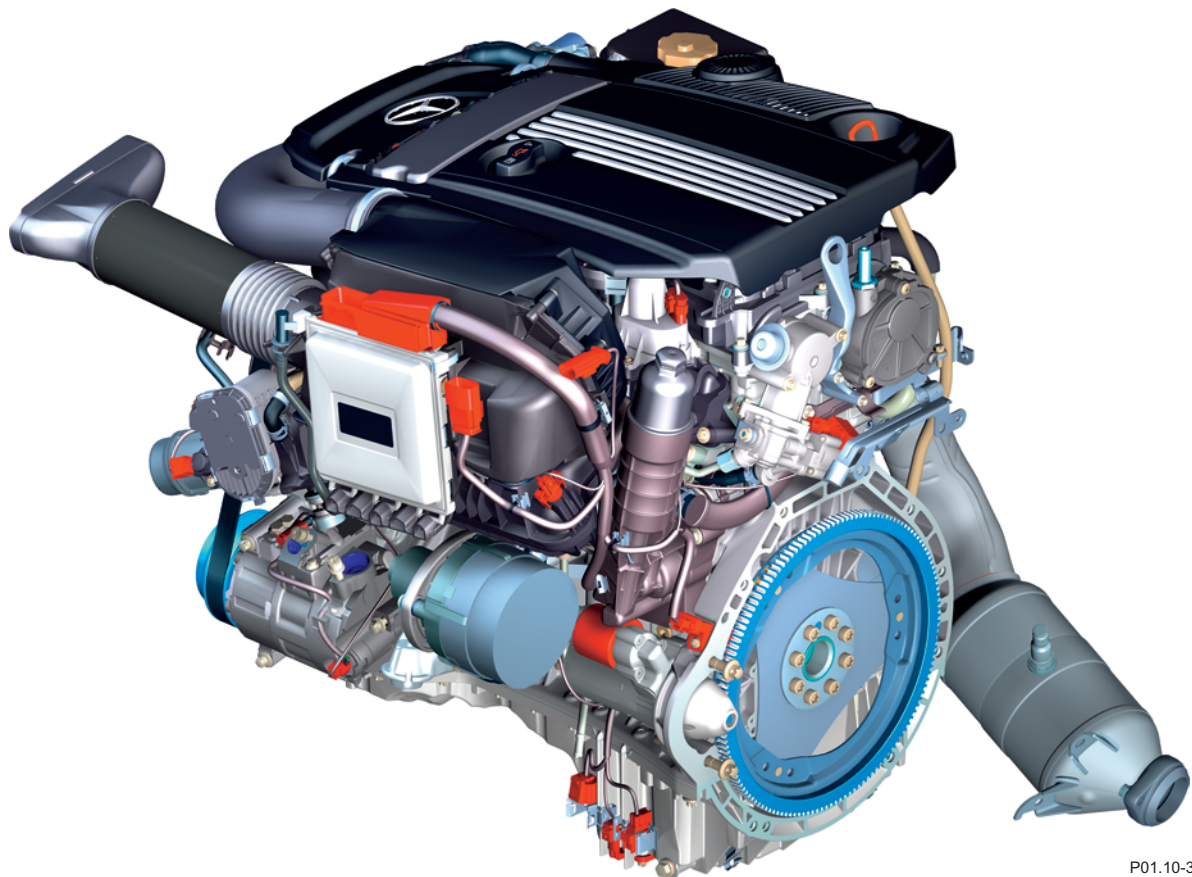

M 271 EVO output end

M 271 EVO		271.820	271.860	271.860
Displacement	cm ³	1,796	1,796	1,796
Rated output	kW at rpm	115 5,000	135 5,250	150 5,500
Rated torque	Nm at rpm	250 1,600...4,300	270 1,800...4,600	310 2,000...4,300
Compression ratio	ε	9.8 : 1	9.3 : 1	9.3 : 1

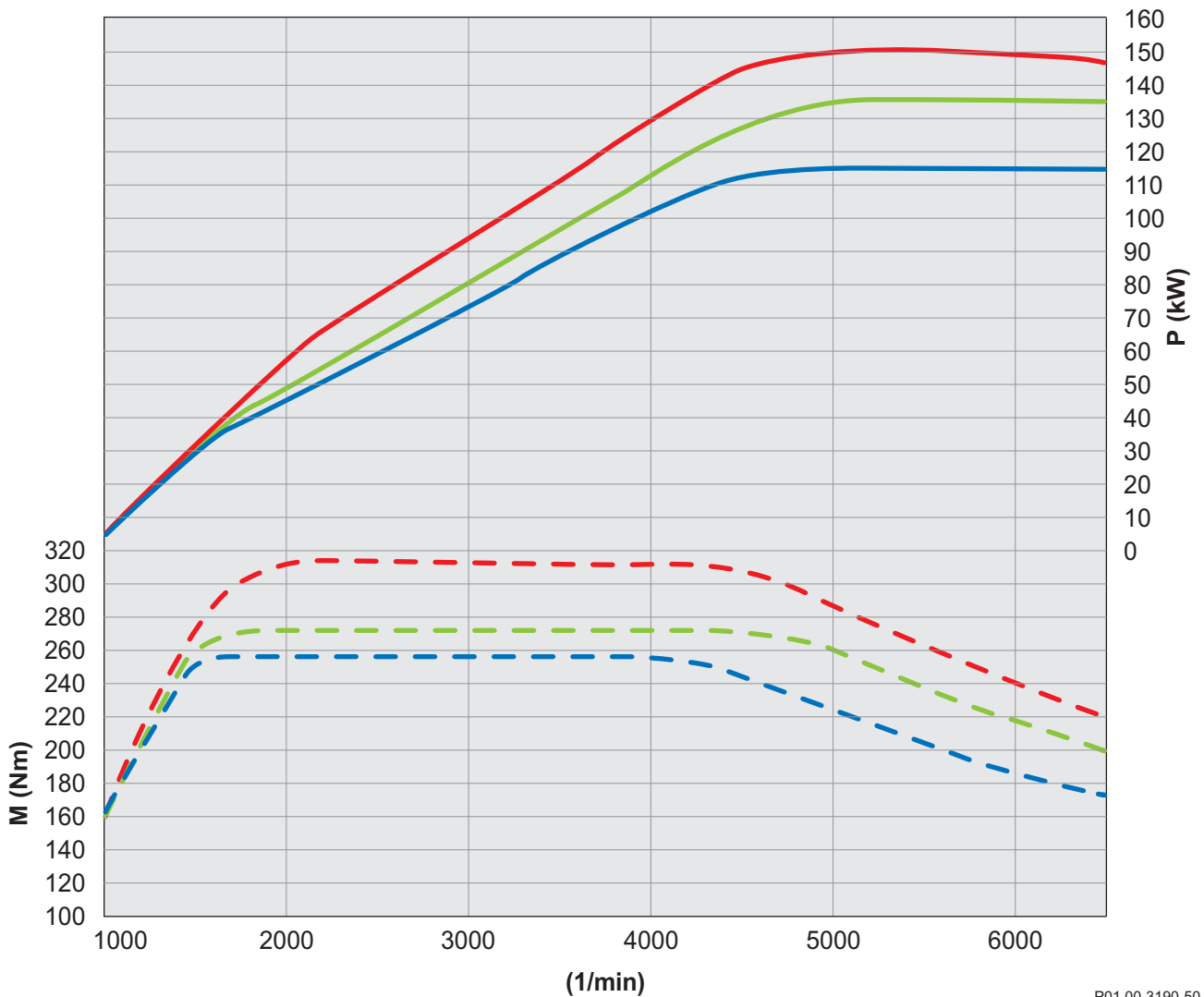

P01.00-3190-50

Performance graph

■ M 271 EVO with 115 kW
 ■ M 271 EVO with 135 kW
 ■ M 271 EVO with 150 kW

Cylinder head

The cylinder head and the intake valves have been adapted to cope with the demands of homogeneous direct injection.

The M 271 EVO operates according to the four-valve concept with two camshafts, two camshaft adjusters and central spark plugs.

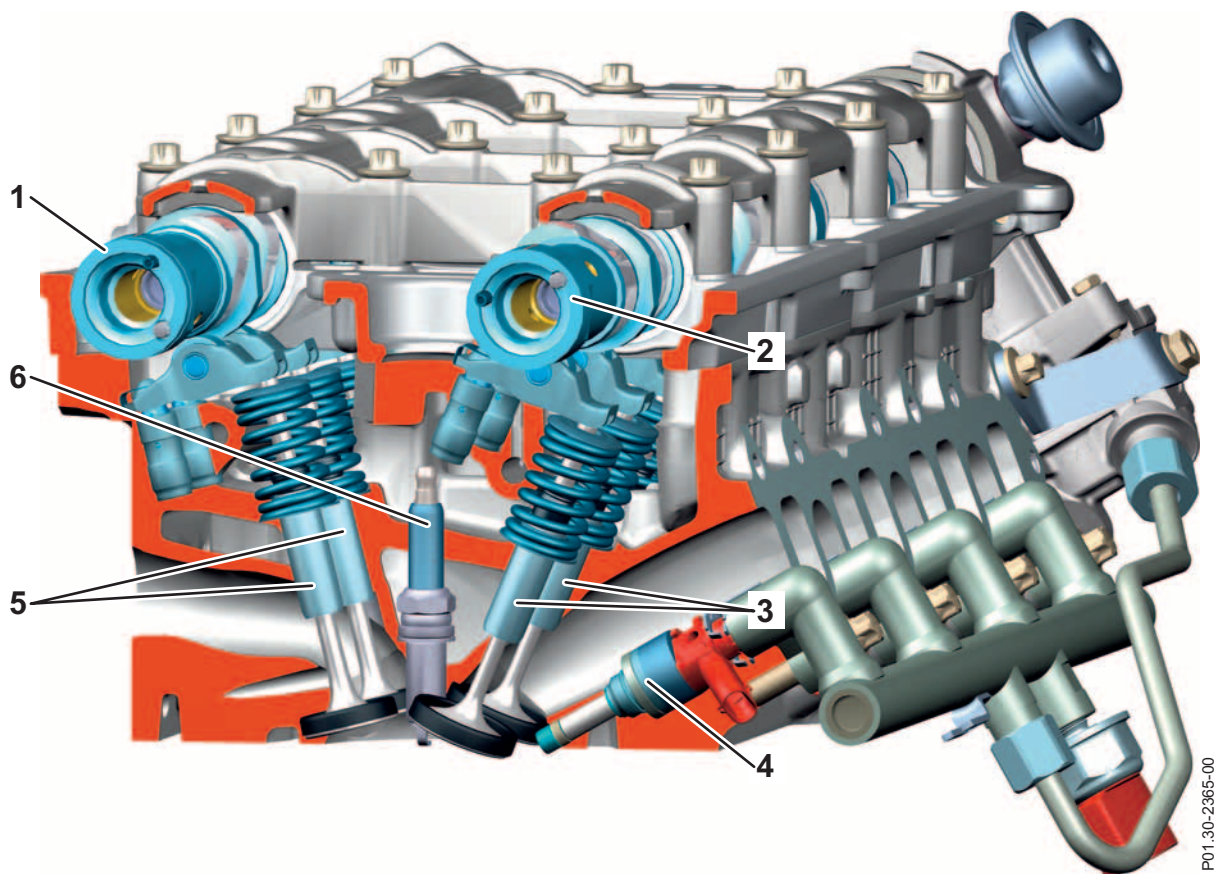

Cylinder head

- | | |
|--------------------|------------------|
| 1 Exhaust camshaft | 4 Fuel injector |
| 2 Intake camshaft | 5 Exhaust valves |
| 3 Intake valves | 6 Spark plug |

Camshaft adjuster

The camshaft adjusters of the forged intake and exhaust camshafts are vane-cell adjusters and have been further improved. They allow the timing to be varied steplessly and more quickly than before.

The camshaft adjuster is a hydraulic swivel drive. The adjustment angle is 40° (crank angle) – corresponding to an angle of 20° performed at the adjuster (exhaust). The adjustment of the camshafts optimizes the engine torque curve and improves exhaust characteristics.

A spring-loaded pin locks the camshaft adjuster in the basic position when the engine is switched off in order to prevent uncontrolled movement of the adjuster during start-up.

The new camshaft adjuster is 34% lighter while the rate of adjustment is twice as fast.

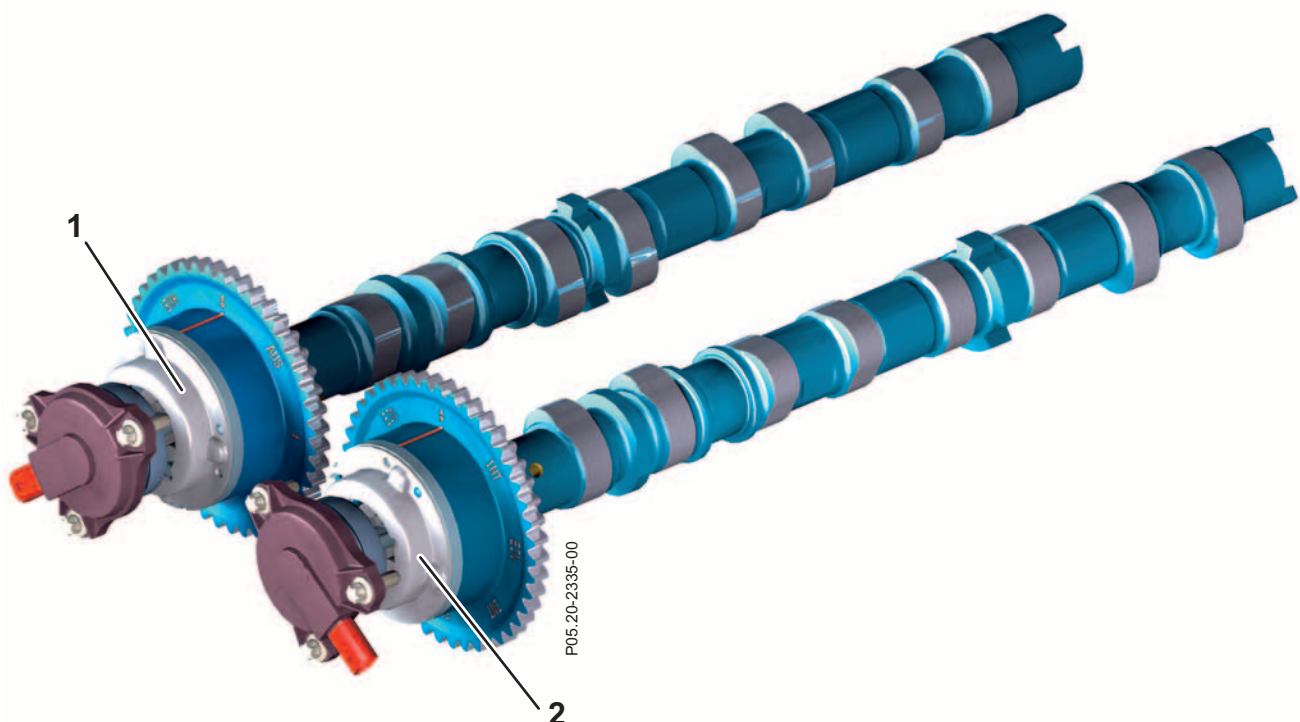

Camshaft adjuster

- 1 Exhaust camshaft adjuster
- 2 Intake camshaft adjuster

Crankcase

Crankcase ventilation

The M 271 EVO features two crankcase ventilation systems:

- Partial load ventilation with single cyclone oil separator
- Full load ventilation with double cyclone oil separator

Partial load ventilation

The single cyclone oil separator is responsible for separating the oil at the partial load ventilation line. The partial load ventilation line runs from the left engine support flange into the charge air distribution line downstream of the throttle valve actuator.

Via an opening in the crankcase the blow-by gas (blow-by quantity) flows into the single cyclone separator which is located behind the left engine support. The oil separator is in the form of a cyclone: Incoming air is made to spiral and the resulting centrifugal forces separate the oil, which flows back into the housing.

The air cleaned in this way leaves the oil separator through a combination valve installed above the cyclone, which acts as a check valve in the event of overpressure in the charge air distribution line and as an air shutoff valve to protect the catalytic converter.

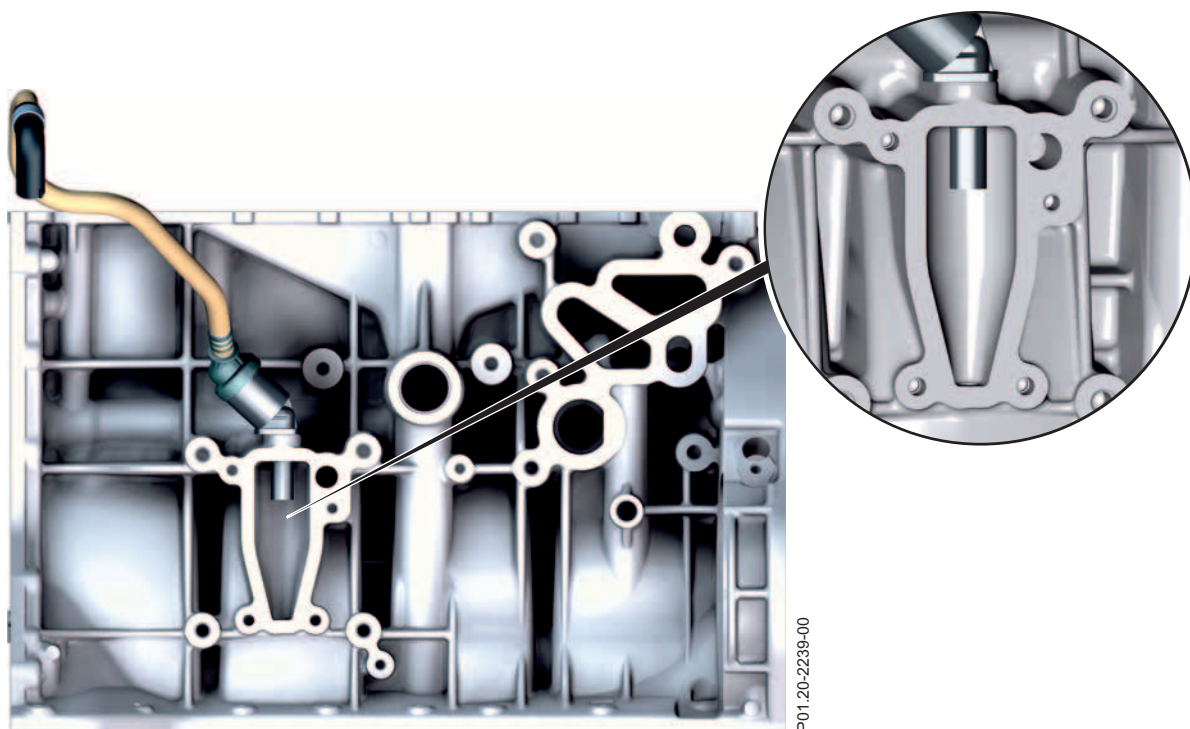

Partial load ventilation with cyclone oil separator

Full load ventilation

The full load ventilation line runs from the oil separator into the charge air line upstream of the turbocharger. The oil separators are integrated in the cylinder head cover. The full load ventilation gases emerge on the exhaust side.

A parallel double cyclone oil separator provides highly efficient and precise oil separation.

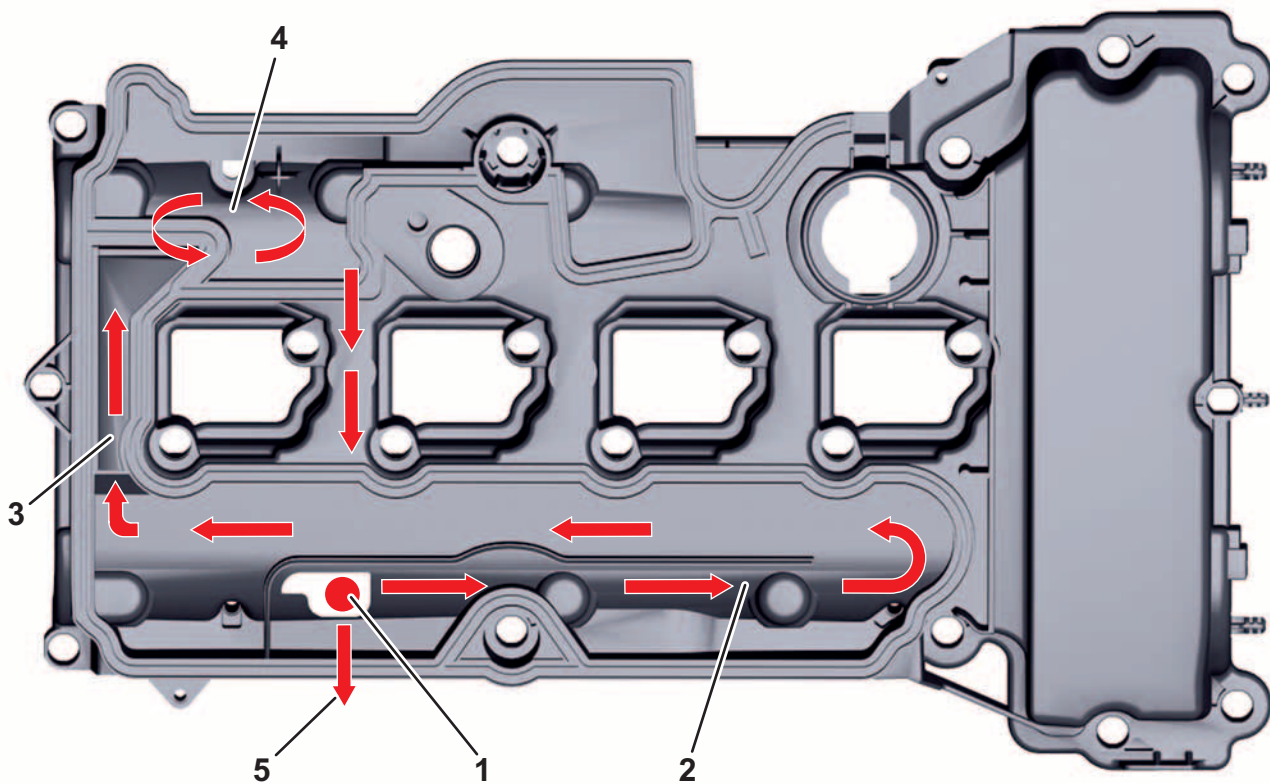

P01.20-2240-00

Blow-by gases in the cylinder head cover

- 1 Entry of blow-by gases
- 2 Volume separator
- 3 Ramp
- 4 Double cyclone oil separator
- 5 Exit of blow-by gases

Chain drive

Low-noise chain drive

The camshafts are driven by a newly developed toothed bush chain.

The bearing for the leading slide rail and tensioning rail is arranged to have no contact with the timing case cover. This results in a considerable reduction in noise.

The lower position of the chain tensioner and resultant reduction in force in the chain drive contribute to this.

The two Lanchester balance shafts are driven by a second chain, which is also located at the front of the engine. The oil pump is driven via the left Lanchester balance shaft.

A new simplex bush chain is used for this.

Note

Besides the lower mass, the impact forces of the bushes in the tooth roots are reduced by the chain links striking the shoulders on each side of the sprocket and absorbing a part of the impact pulses.

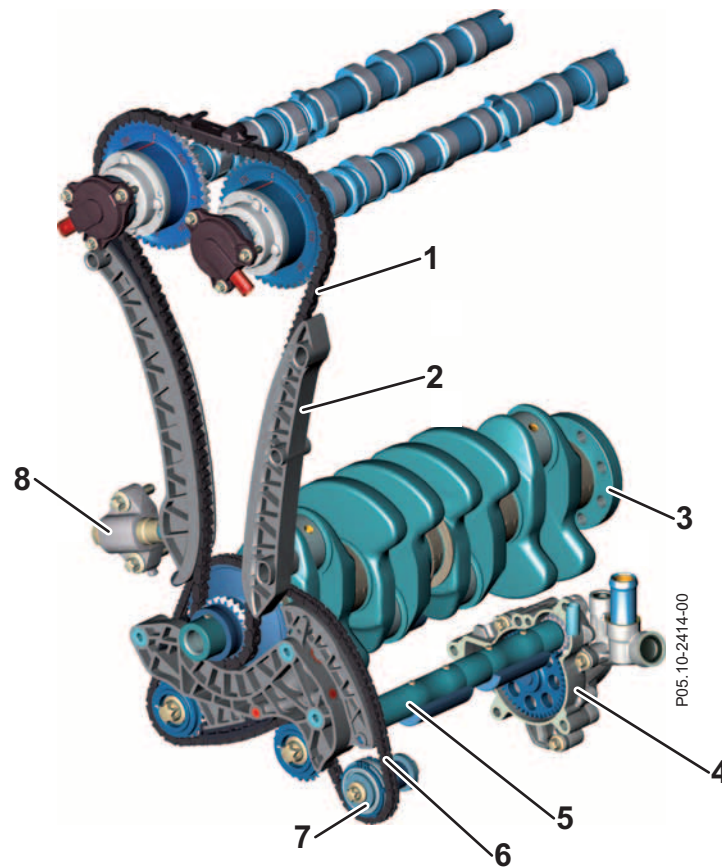

Chain drive

- 1 Toothed bush chain: Drives the camshafts
- 2 Slide rail
- 3 Crankshaft
- 4 Oil pump
- 5 Balance shaft
- 6 Simplex bush chain: Drives the Lanchester balance shafts
- 7 Sprocket
- 8 Chain tensioner with tensioning rail

Crank assembly

Lanchester balancer

With the new Lanchester balancer it has been possible to achieve a considerable reduction in disturbing vibrations caused by piston movements, providing comfortable smooth running.

The Lanchester balancer operates with two contrarotating balance shafts, each mounted in three bearings in a one-piece die-cast aluminum housing.

These tubular steel shafts are inserted into the bearing channel of the housing and are then bolted to the imbalance mass segments. The faces of the imbalance mass segments also act as locators and axial bearings for the shafts in the housing.

i Note

The housing in which the balance shafts are mounted is located inside the oil pan and is bolted to the crankcase from underneath. This housing also acts as a ladder-type frame which serves as a stiffening bridge for the bearing seats and thus improves the cross-bracing of the crankcase.

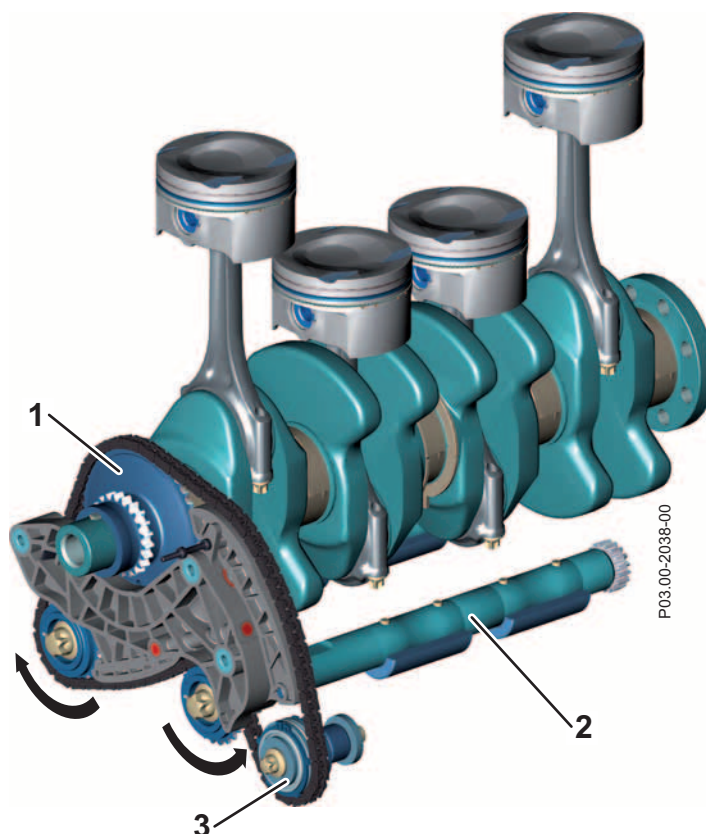

Lanchester balancer

- 1 Crankshaft drive
- 2 Balance shaft

- 3 Sprocket



General

The major assemblies in the M 271 EVO have been relocated, due in part to the omission of the mechanical supercharger.

The belt pulley of the crankshaft drives the following major assemblies:

- Power steering pump
- Refrigerant compressor
- Alternator
- Coolant pump

They are driven by means of a one-piece, low-maintenance poly-V belt. The poly-V belt is tensioned by an automatic belt tensioner with tensioner pulley.

i Note

When installing the poly-V belt, make sure the installation position is correct as described in the repair instructions.

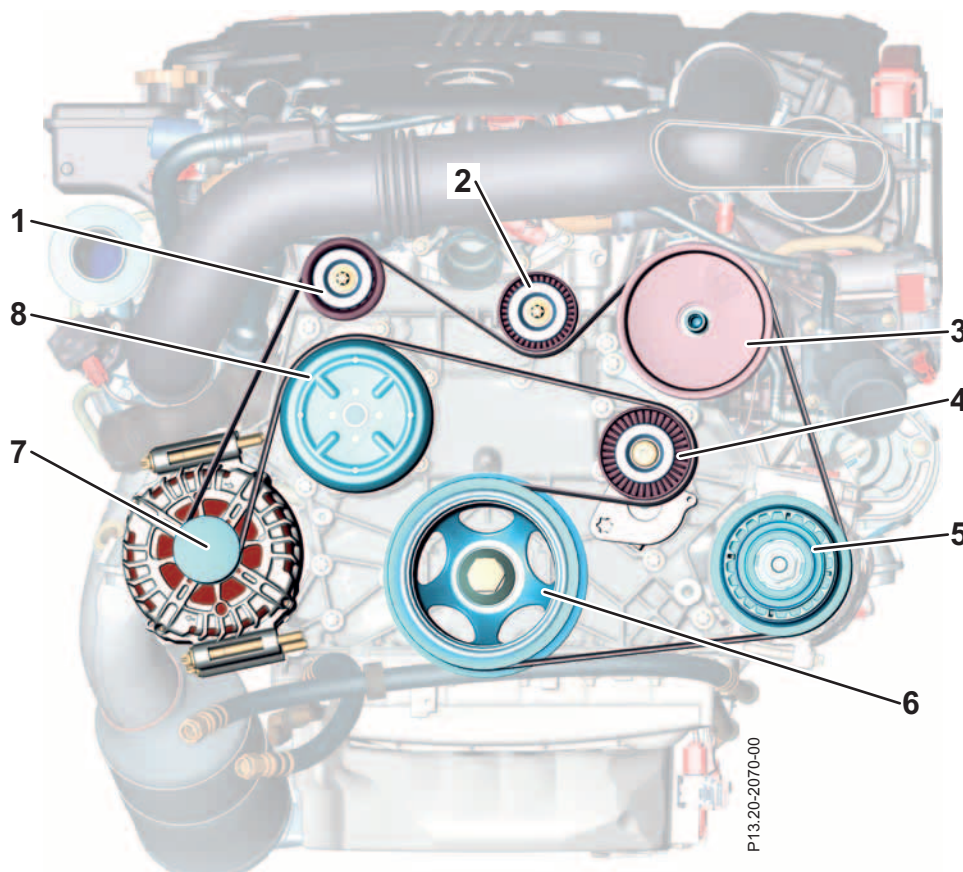

Belt drive

- | | |
|--|--------------------------|
| 1 Guide pulley | 5 Refrigerant compressor |
| 2 Guide pulley | 6 Belt pulley |
| 3 Power steering pump | 7 Alternator |
| 4 Belt tensioner with tensioner pulley | 8 Coolant pump |

Homogeneous direct injection

Injection technology

The M 271 EVO features homogeneous direct injection with spark ignition and turbocharging. These improve fuel economy and significantly reduce pollutant emissions.

Operating principle of fuel injection control

The current fuel pressure in the rail is registered by the rail pressure sensor and forwarded to the quantity control valve. This valve causes the fuel high-pressure pump to build up a pressure of up to 140 bar in the rail.

The exact injection time is calculated by the ME-SFI control unit.

The ME-SFI control unit evaluates signals from the following components:

- Throttle valve actuator
- Camshaft sensor
- Crankshaft Hall sensor
- Rpm sensor
- Pressure sensors
- Temperature sensor

The timing of the intake and exhaust valves is variable.

This means that the mixture formation in the combustion chamber can be adapted to suit the current operating conditions.

The intake and exhaust valves are controlled by the adjustable camshafts. The exact position of the camshafts is detected by the camshaft sensors and forwarded to the ME-SFI control unit.

Rail

In a storage-type fuel injection system with fuel rail the pressure generation and injection functions are decoupled. The injection pressure is generated and regulated by the fuel high-pressure pump. The pressure is available in the rail during injection. The ME-SFI control unit actuates the quantity control valve and the fuel injectors spray the fuel into the combustion chamber with high precision.

Fuel injectors

The fuel injectors are installed so that the fuel is injected at a certain angle. This angle is selected so as to prevent the fuel from being deposited on the wall of the combustion chamber or flooding the intake valves.

The multi-hole valves in the fuel injectors produce individual jets which are precisely adjusted according to the charge movement and the internal pressure in the cylinder.

This results in highly stable combustion, low emissions and low fuel consumption.

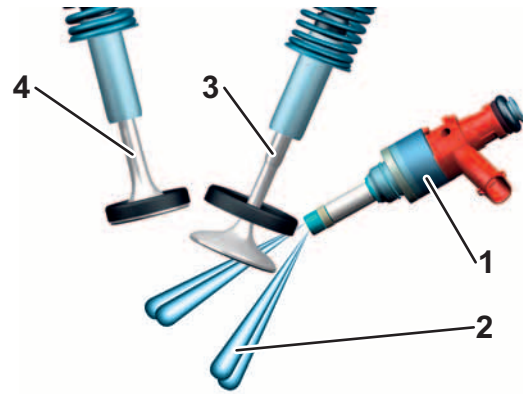

P07.03-2272-00

Fuel injector with individual jets

- 1 Fuel injector
- 2 Individual jets
- 3 Intake valve
- 4 Exhaust valve

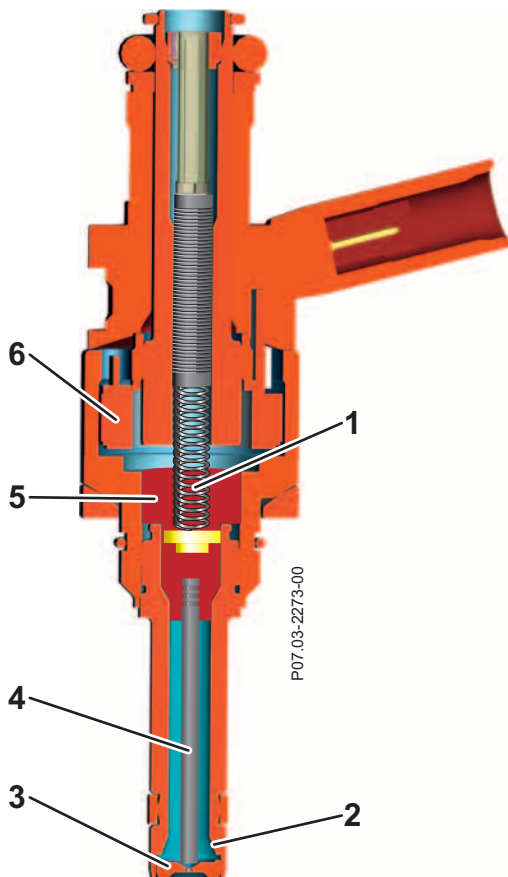

P07.03-2273-00

Cross section through the fuel injector

- 1 Coil spring
- 2 Valve seat
- 3 Multi-hole disk
- 4 Nozzle needle
- 5 Solenoid armature
- 6 Magnet coil

Homogeneous direct injection

Fuel high-pressure pump

The fuel high-pressure pump is located at the rear of the cylinder head. It is driven via the intake camshaft. The fuel high-pressure pump is a single-plunger pump. Four cams enable four deliveries to be made for each rotation of the camshaft.

Quantity control valve

The quantity control valve forms a unit with the fuel high-pressure pump. It functions as an intake throttle (proportional valve) and serves to regulate the fuel quantity (max. fuel pressure = 140 bar). For the regulation process, the current fuel pressure is registered by the rail pressure sensor in the rail.

Rail pressure sensor

The rail pressure sensor measures the current fuel pressure in the rail and forwards a corresponding voltage signal to the ME-SFI control unit. When the engine is switched off, the quantity control valve interrupts the fuel supply, thus dissipating the high pressure.

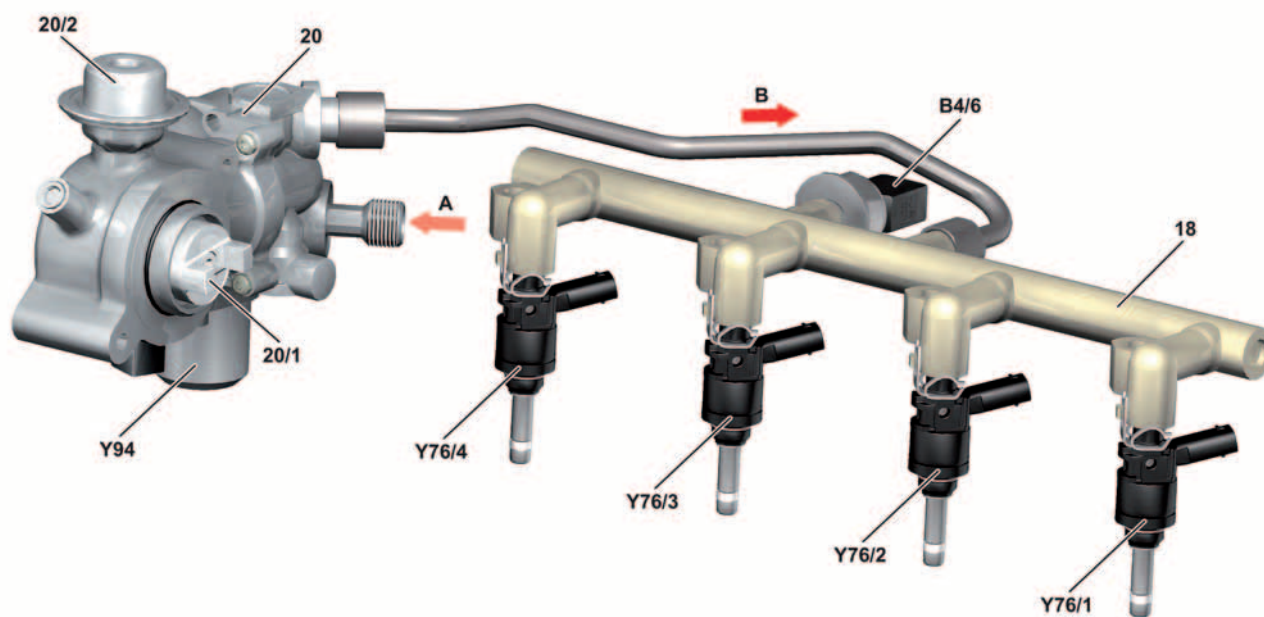

P07.02-2110-79

High-pressure system

18	Rail	Y76/1	Cylinder 1 fuel injector
20	Fuel high-pressure pump	Y76/2	Cylinder 2 fuel injector
20/1	Driver (drive system)	Y76/3	Cylinder 3 fuel injector
20/2	Fuel pressure damper	Y76/4	Cylinder 4 fuel injector
B4/6	Rail pressure sensor	Y94	Quantity control valve

A	Fuel feed from fuel tank (fuel low pressure)
B	Fuel feed to rail (fuel high pressure)

Low-pressure system

The low-pressure system operates with a control unit for the fuel pump and a fuel pressure sensor in the fuel feed line.

The control unit is integrated in the CAN network (CAN = Controller Area Network) of the engine. It regulates the fuel pump according to the engine requirements. The fuel pressure is kept constant as a reference.

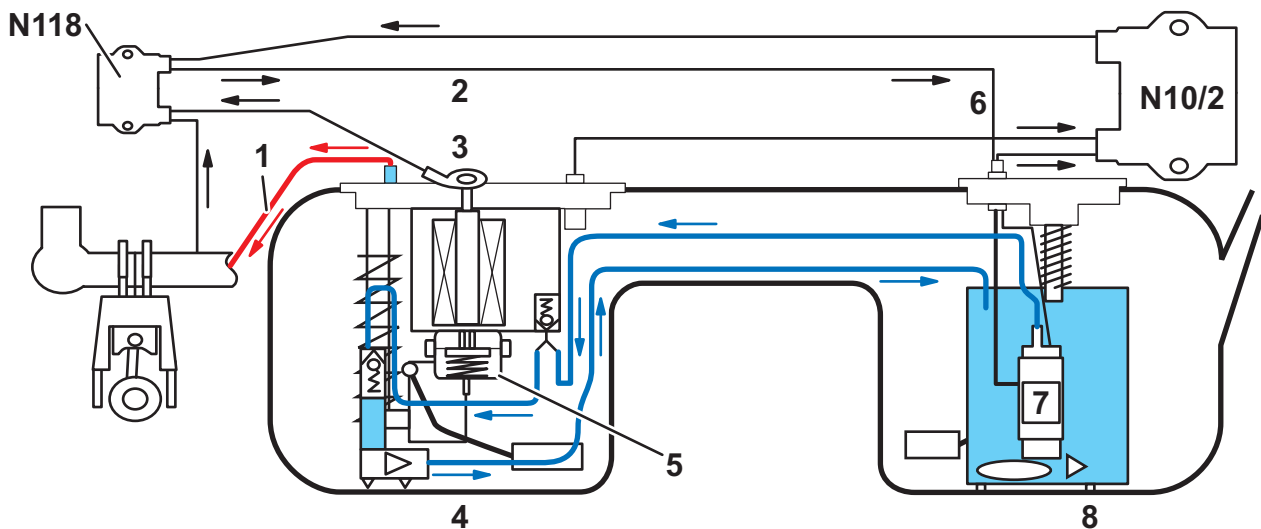

P07.00-2148-00

Low-pressure system

- 1 Fuel feed line
- 2 Filter flange
- 3 Fuel pressure sensor
- 4 Suction jet pump 1
- 5 Pressure relief valve
- 6 Pump flange
- 7 Uncontrolled fuel pump
- 8 Suction jet pump 2

- N10/2 Rear SAM control unit with fuse and relay module
- N118 Fuel tank control unit

System overview

The power output and torque of the M 271 EVO are increased by the use of a turbocharger with charge air cooling. Forced induction by means of a compressor is no longer implemented.

Operating principle of forced induction

During forced induction, the flow energy of the exhaust gas is used to drive the turbocharger.

Fresh, clean air flows to the compressor inlet via the air filter. It is directed via the compressor outlet into the charge air line upstream of the charge air cooler.

The air in the charge air line is compressed as a result of the high rotational speed of the compressor turbine wheel that creates a high volumetric flow. The maximum boost pressure is 1.2 bar.

The noise damper at the compressor outlet dampens the boost pressure variations and the associated flow noises that occur during rapid rpm changes.

The compressed air flows via the charge air line to the charge air cooler. This cools the charge air, which has heated up due to compression, and directs it via the charge air line to the charge air distribution line.

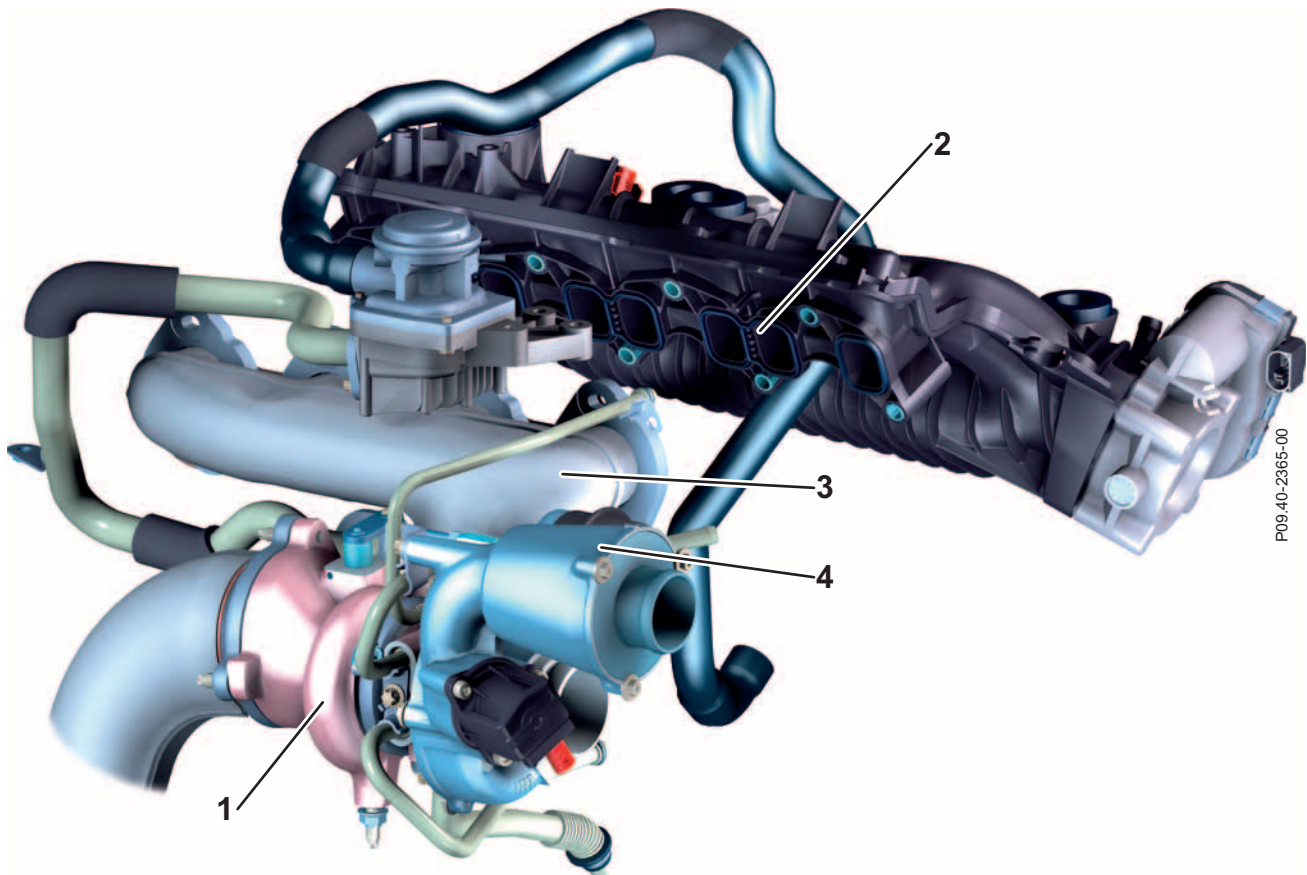

System overview

- 1 Turbocharger
- 2 Charge air distribution line
- 3 Exhaust manifold
- 4 Noise damper

System overview

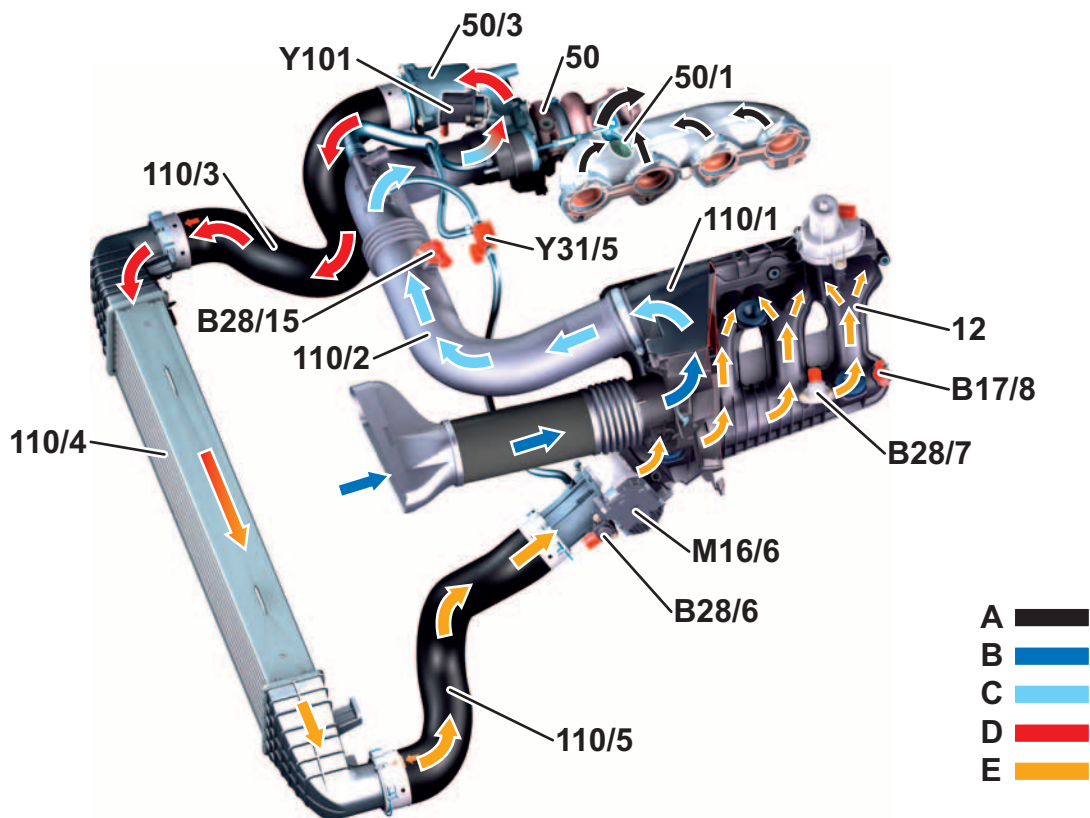

P09.00-2106-00

Function schematic of forced induction

12 Charge air distribution line
 50 Turbocharger
 50/1 Boost pressure control flap (wastegate)
 50/3 Noise damper
 110/1 Air filter housing
 110/2 Charge air line
 110/3 Charge air line to charge air cooler
 110/4 Charge air cooler

110/5 Charge air line to throttle valve actuator
 B17/8 Charge air temperature sensor
 B28/6 Pressure sensor upstream of throttle valve
 B28/7 Pressure sensor downstream of throttle valve
 B28/15 Pressure sensor upstream of compressor impeller
 M16/6 Throttle valve actuator
 Y31/5 Boost pressure control pressure transducer
 Y101 Blow-off valve

A Exhaust gas
 B Intake air (unfiltered)
 C Intake air (filtered)
 D Charge air (uncooled)
 E Charge air (cooled)



Operating principle of boost pressure control flap

The boost pressure is regulated by means of a boost pressure control flap (wastegate) installed at the turbine inlet.

The boost pressure control pressure transducer actuates the vacuum cell of the boost pressure control flap with boost pressure.

If the boost pressure is too high, the exhaust gases are directed around the turbine. This reduces the speed of the turbocharger and thus the boost pressure.

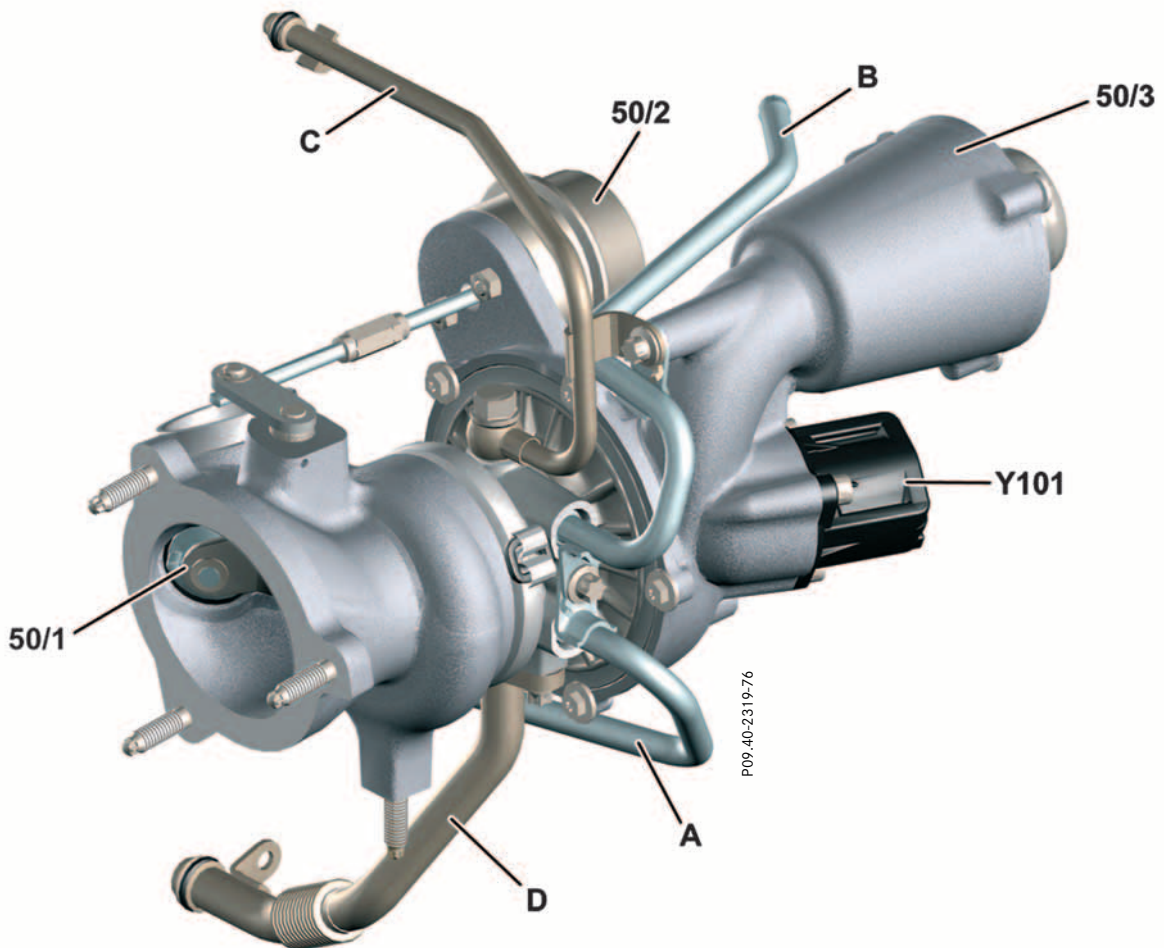

Component overview

50/1	Boost pressure control flap	A	Coolant feed line
50/2	Boost pressure control flap vacuum unit	B	Coolant return line
50/3	Noise damper	C	Engine oil feed line
Y101	Blow-off switchover valve	D	Engine oil return line

Boost pressure control

Boost pressure control pressure transducer

The pressure transducer is actuated by the ME-SFI control unit according to a performance map and according to load.

To do this, the ME-SFI control unit evaluates the following sensors and functions:

- Charge air temperature sensor
- Pressure sensor upstream of throttle valve
- Pressure sensor upstream of compressor impeller
- Accelerator pedal sensor: Load request from driver
- Crankshaft Hall sensor: Engine speed
- Knock control
- Transmission overload protection
- Overheating protection

The pressure transducer actuates the vacuum cell of the wastegate with boost pressure from the charge air line. The vacuum cell then opens the wastegate, thus opening the bypass. The exhaust flow bypasses the turbine wheel via the bypass line, regulating the boost pressure and limiting the turbine speed.

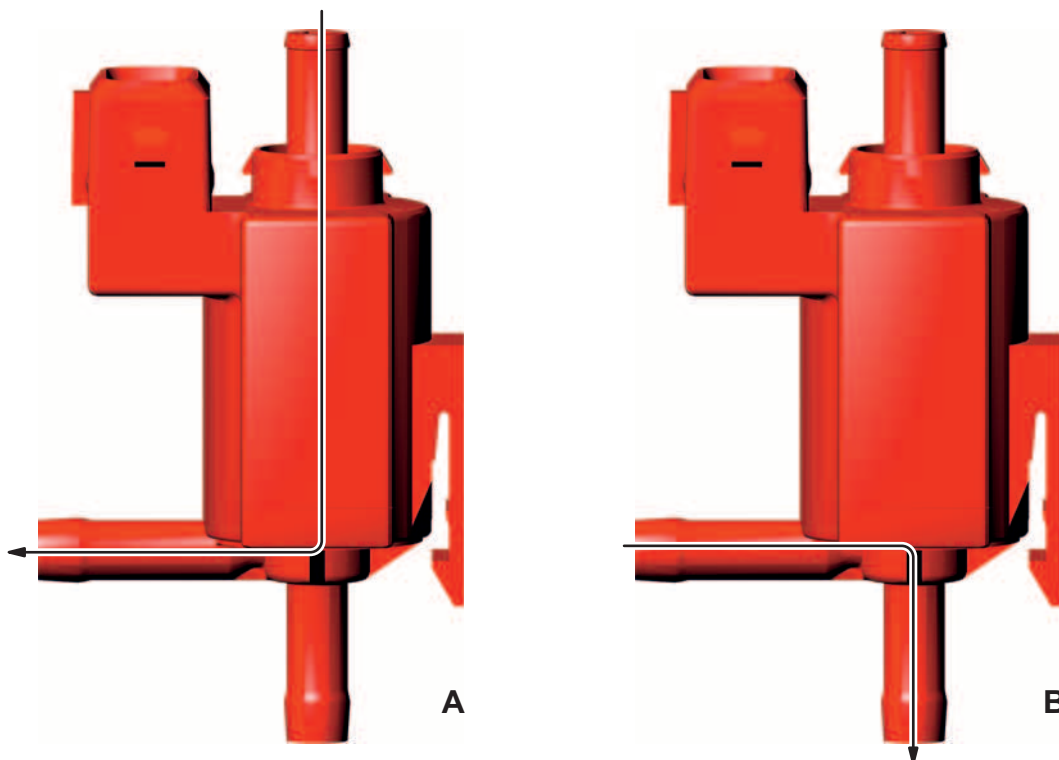

P09.40-2366-00

Boost pressure control pressure transducer

A Bypass closed

B Bypass open

Pressure sensor upstream of throttle valve

The pressure sensor upstream of the throttle valve measures the charge air pressure in the charge air line.

Operating principle

The charge air pressure deforms the membrane, which acts on the potentiometer. This causes the resistance of the potentiometer to change, thus influencing the voltage signal that the pressure sensor forwards to the ME-SFI control unit.

Pressure sensor downstream of throttle valve

The pressure sensor downstream of the throttle valve measures the charge air pressure in the charge air distribution line and forwards this value to the ME-SFI control unit.

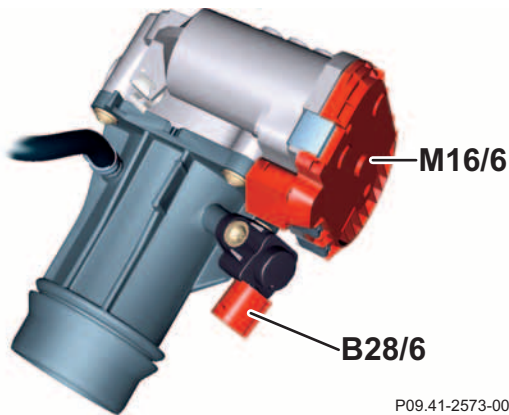

Pressure sensor upstream of throttle valve

- M16/6 Throttle valve actuator
- B28/6 Pressure sensor upstream of throttle valve

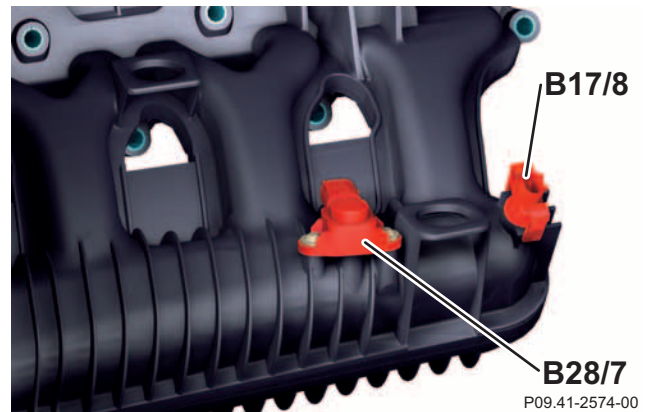

Pressure sensor downstream of throttle valve

- B17/8 Charge air temperature sensor
- B28/7 Pressure sensor downstream of throttle valve

Boost pressure control

Pressure sensor upstream of compressor impeller

The pressure sensor upstream of the compressor impeller registers the pressure on the clean air side for the ME-SFI control unit.

This enables it to detect any sudden pressure drop, e.g. due to clogging of the air filter cartridge. The pressure sensor upstream of the compressor impeller is located in the charge air line upstream of the turbocharger.

i Note

All the pressure sensors operate according to the same principle – they are controlled by positive pressure.

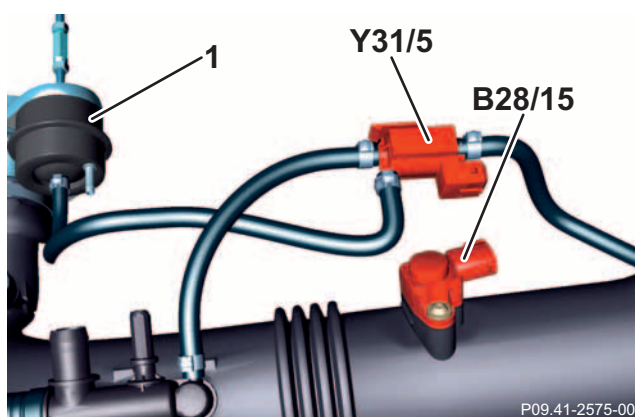

Pressure sensor upstream of compressor impeller

- | | |
|--------|---|
| 1 | Vacuum unit |
| Y31/5 | Boost pressure control pressure transducer |
| B28/15 | Pressure sensor upstream of compressor impeller |

Electric blow-off valve

Due to the inertia of the shaft, the compressor impeller and the turbine wheel, the turbocharger always spins on slightly after the vehicle starts to decelerate. Because of this, a boost pressure surge runs back to the compressor when the throttle valve actuator is closed quickly.

This boost pressure surge causes a situation at the compressor impeller where there is a low delivery volume and high pressures, which leads to so-called "turbocharger whistling" (brief howling and mechanical stress).

In order to prevent this boost pressure surge, the blow-off valve opens and quickly releases the pressure in the intake line.

When the ME-SFI control unit detects the transition from load mode to deceleration mode, it actuates the blow-off valve. The blow-off valve opens the bypass at the compressor impeller and the boost pressure is reduced. In load mode the blow-off valve is closed by an integral spring.

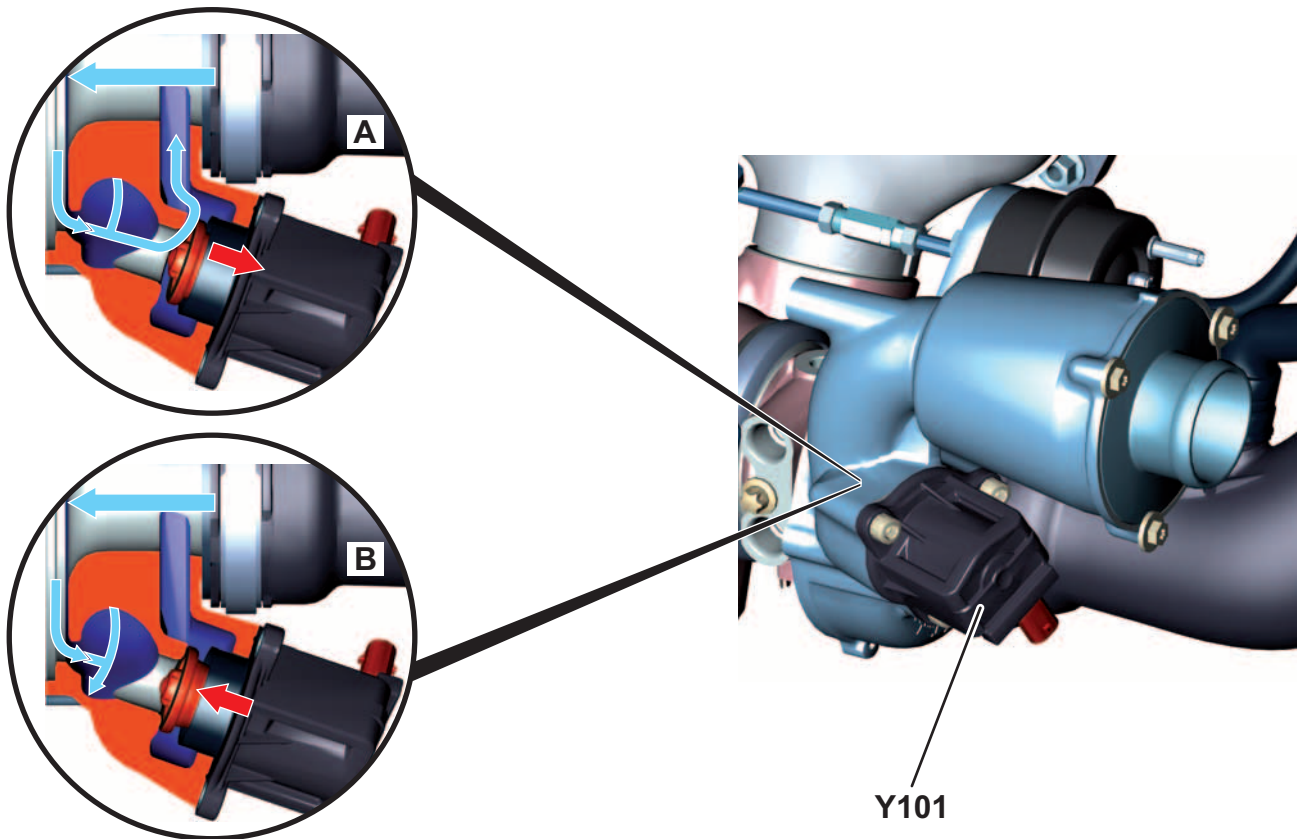

P09.40-2367-00

Operating principle of blow-off valve

- Y101 *Blow-off valve*
- A *Blow-off valve open*
- B *Blow-off valve closed*

Swirl flap control

General

The swirl flap control changes the air ducting in the intake ports. Each cylinder has two intake ports. One of these can be closed by a swirl flap.

The swirl flap actuator motor adjusts the swirl flaps via a linkage. Four of the eight intake ports are continually closed for the purpose of "swirl generation".

For the swirl flap control the ME-SFI control unit scans the following sensors:

- Pressure sensor downstream of throttle valve
- Crankshaft Hall sensor
- Swirl flap Hall sensor

The ME-SFI control unit actuates the swirl flap actuator motor with a pulse width modulated signal according to a performance map.

The swirl flaps are adjusted particularly in the warm-up phase in order to achieve better mixture formation. At idle and at low engine speeds the swirl flaps are closed. This produces a strong swirl effect, which has a positive influence on mixture formation.

The swirl flaps are adjusted according to load and engine speed in order to produce the optimum movement of air at all times. At high engine loads the swirl flaps are fully open.

The swirl flaps are open when de-energized. This is ensured by a return spring integrated in the actuator motor.

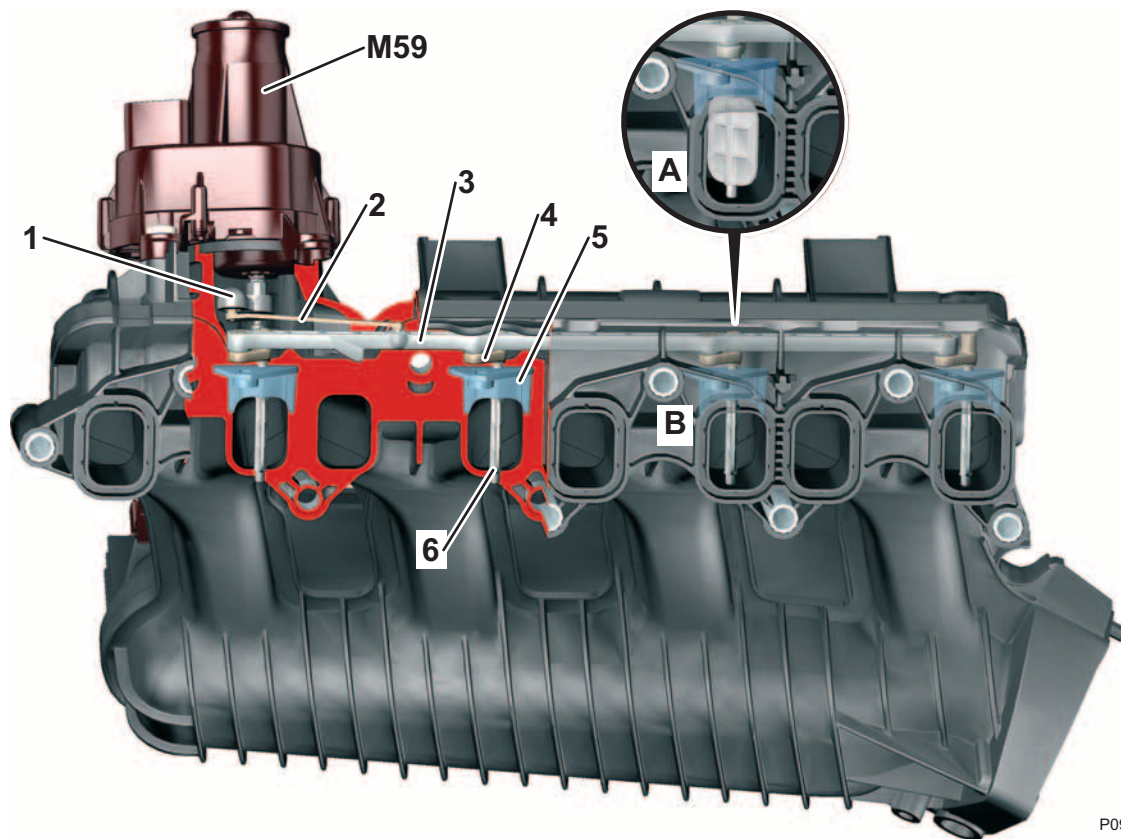

P09.41-2576-00

Sectional view of charge air manifold

- 1 *Adjusting lever of actuator motor*
- 2 *Linkage of actuator motor*
- 3 *Adjustment shaft*
- 4 *Adjusting lever of swirl flap*
- 5 *Upper guide of swirl flap*
- 6 *Swirl flap*
- M59 *Swirl flap actuator motor*

- A *Swirl flap closed*
- B *Swirl flap open*

Lambda control

Operating principle of lambda control

The M 271 EVO operates with two lambda (oxygen) sensors. The oxygen sensor upstream of the catalytic converter measures oxygen variations in the exhaust flow. The oxygen sensor downstream of the catalytic converter measures the residual oxygen in the exhaust gas after exhaust treatment in the catalytic converter.

In order to achieve a higher exhaust conversion rate in the catalytic converters, the mixture composition is regulated within tight limits in the range of $\lambda = 1$.

The residual oxygen is an important indicator of the mixture composition. A low residual oxygen content means a lack of air; in other words a "rich" mixture. A high residual oxygen content means a surplus of air, or a "lean" mixture. If the oxygen sensor detects that the mixture is too rich, the ME-SFI control unit shortens the injection period until the mixture becomes leaner. If the mixture is too lean, the process operates in reverse.

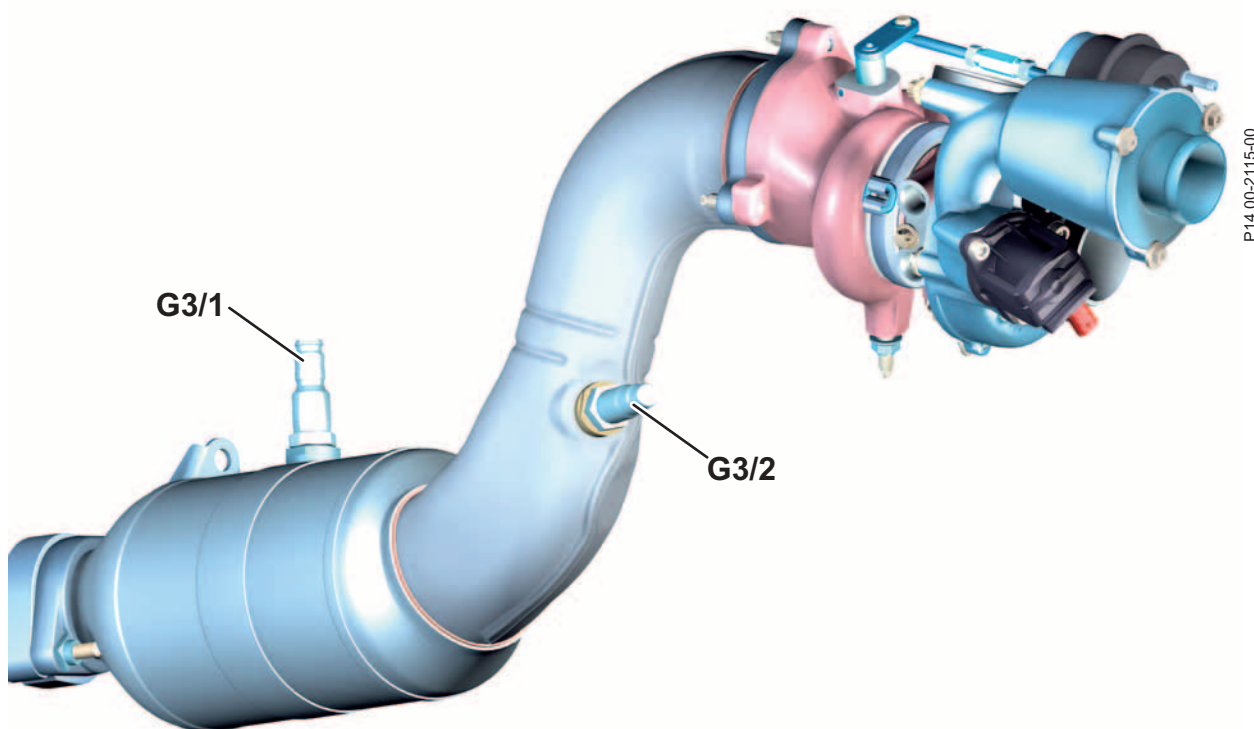

P14.00-2115-00

Lambda control

G3/1 Oxygen sensor downstream of catalytic converter

G3/2 Oxygen sensor upstream of catalytic converter



Oxygen sensor upstream of catalytic converter

The oxygen sensor upstream of the catalytic converter is a wideband oxygen sensor with two voltage-jump sensors.

Oxygen sensor downstream of catalytic converter

The oxygen sensor measures the residual oxygen content in the exhaust gas for the following purposes:

- Two-sensor control
- Monitoring of catalytic converter efficiency

Exhaust system

The exhaust system consists of a single-pipe system with near-engine mounted catalytic converter, under-floor catalytic converter and front and rear mufflers.

i Note

The following Technology Guide provides an overview of the exhaust aftertreatment systems and the relevant limits imposed by the emission regulations:

Exhaust aftertreatment for current passenger car model series

Order No. 6516 1337 02

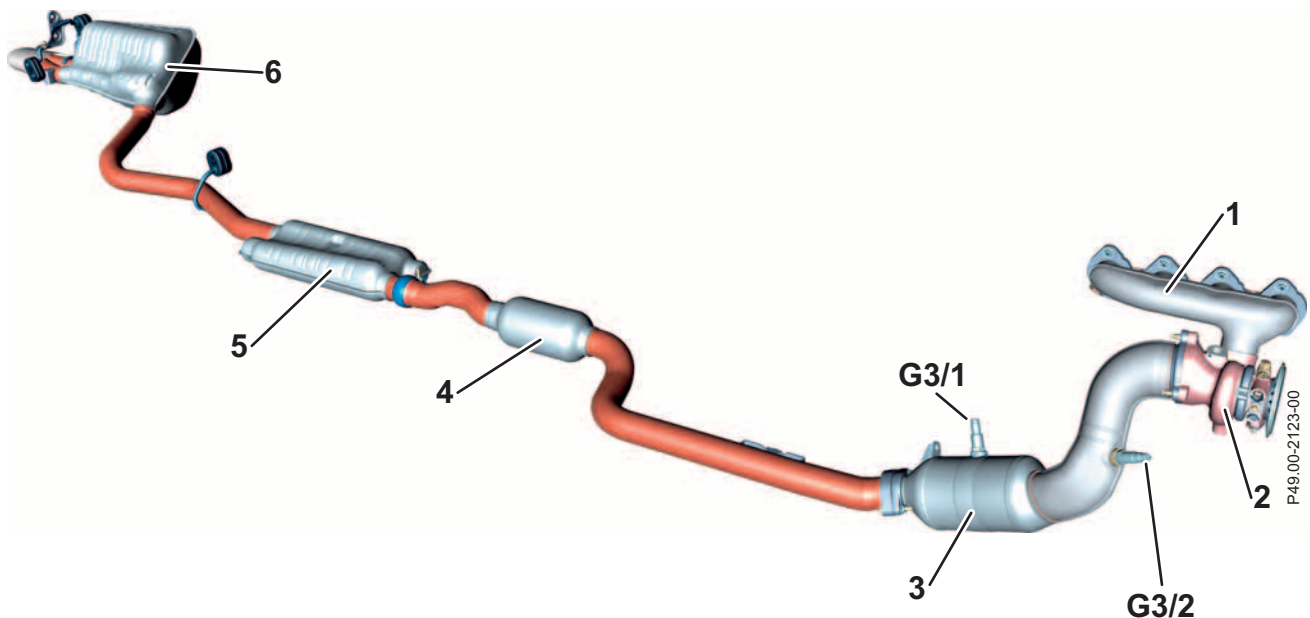

Exhaust system

- 1 Exhaust manifold
- 2 Turbocharger
- 3 Catalytic converter
- 4 Underfloor catalytic converter
- 5 Front muffler
- 6 Rear muffler

- G3/1 Oxygen sensor downstream of catalytic converter
- G3/2 Oxygen sensor upstream of catalytic converter

Secondary air injection

Electric secondary air injection pump

The electric secondary air injection pump adds fresh air to the exhaust in order to heat the catalytic converter to its operating temperature more quickly.

Due to air injection the hot exhaust gas is burned with the fresh air in the exhaust ports. The hydrocarbons (HC) and carbon monoxide (CO) in the exhaust react with the oxygen (O₂) in the fresh air to produce water (H₂O) and carbon dioxide (CO₂).

This afterburning increases the temperature of the exhaust gas and enables the catalytic converter to warm up more quickly. This improves the exhaust emission values in the engine warm-up phase.

After actuation, air injection remains disabled until the coolant reaches a temperature of over 60 °C and then drops back down below 40 °C. This allows the electric secondary air injection pump to cool down in turn.

i Note

The secondary air injection in the M 271 EVO can be actuated via Xentry Diagnostics.

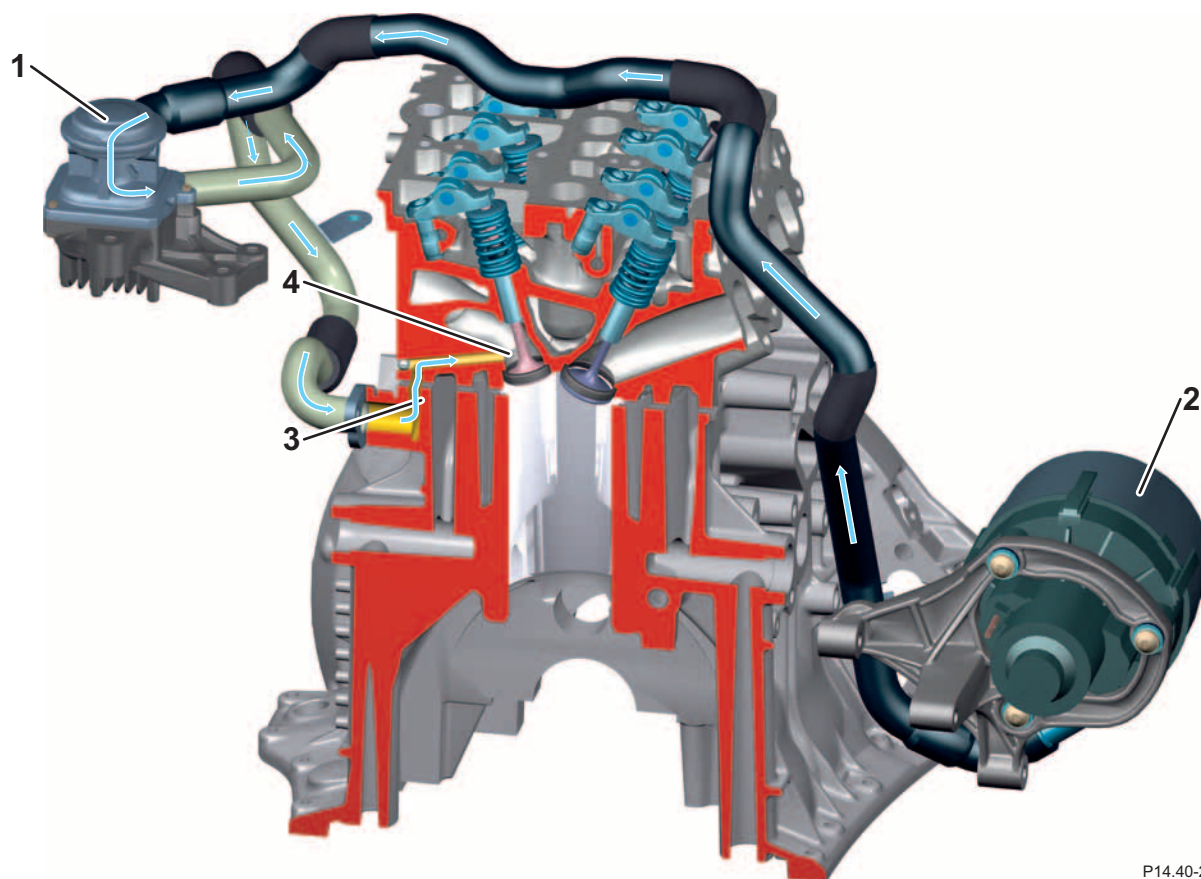

P14.40-2411-00

Secondary air system

- | | |
|---|--------------------------------|
| 1 Air shutoff valve of secondary air injection pump | 3 Air ducting to exhaust valve |
| 2 Secondary air injection pump | 4 Exhaust valve |

Secondary air injection

Air pump switchover valve

The switchover valve actuates the air shutoff valve with vacuum from the vacuum pump to start air injection. The air line to the vacuum pump contains a check valve. This guarantees that the vacuum generated in the switchover valve is built up and maintained.

The switchover valve is actuated by a ground signal direct from the ME-SFI control unit.

Air shutoff valve of secondary air injection pump

When actuated, the air shutoff valve enables air injection. When air injection is shut off, it prevents air from being sucked into the exhaust ports due to the exhaust flow.

The air shutoff valve is actuated with vacuum via the air pump switchover valve. The vacuum causes the diaphragm to open and the injected air from the electric secondary air injection pump can enter the exhaust ports of the cylinder head via the air shutoff valve.

The diaphragm prevents air from entering when there is no vacuum opposite the switchover valve.

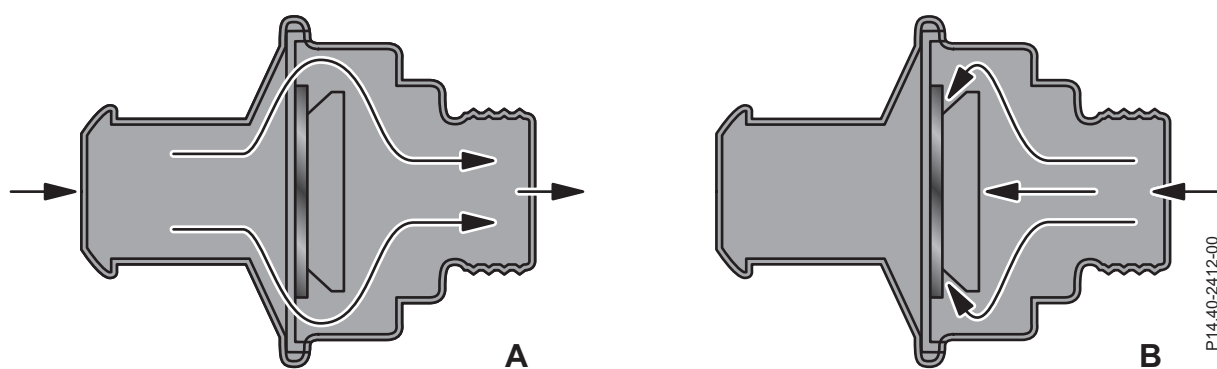

Air shutoff valve

- A Diaphragm open
- B Diaphragm closed

Engine cooling

Operating principle

In the M 271 EVO an electronically controlled two-disk thermostat with three-disk functionality ensures that the coolant temperature is controlled by a performance map.

The coolant temperature is regulated for each operating point according to requirements.

The advantages of this are as follows:

- The friction power of the engine is lower as the oil and engine temperatures are increased in parallel at partial load.
- The engine temperature is significantly reduced in the high-load range, allowing the engine to achieve greater efficiency at these operating points.

When starting from cold, there is no flow through the coolant circuit. No coolant flows through the cylinder head. This enables the combustion chambers and cylinder barrels to heat up quickly in the warm-up phase. When the coolant reaches 80 °C, the thermostat opens the bypass circuit. Only at 103 °C is the target coolant temperature reached under partial load, and the coolant is regulated to this temperature as the cooling circuit starts to open.

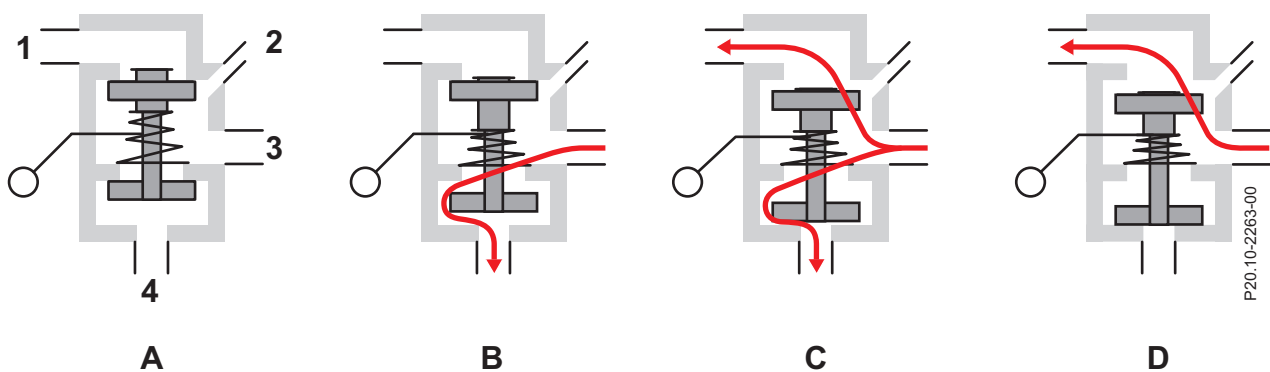

Thermostat settings of the two-disk thermostat with three-disk functionality

- 1 Radiator
- 2 Heater
- 3 Engine
- 4 Bypass

- A Full throttling: Both disks are closed when the engine is cold.
- B Bypass mode: The bypass disk opens at a pressure differential of > 0.7 bar.
- C Mixed mode: The main disk opens above 103 °C (deenergized) or 80 °C (energized).
- D Cooling mode: The main disk is fully open; the bypass is closed.

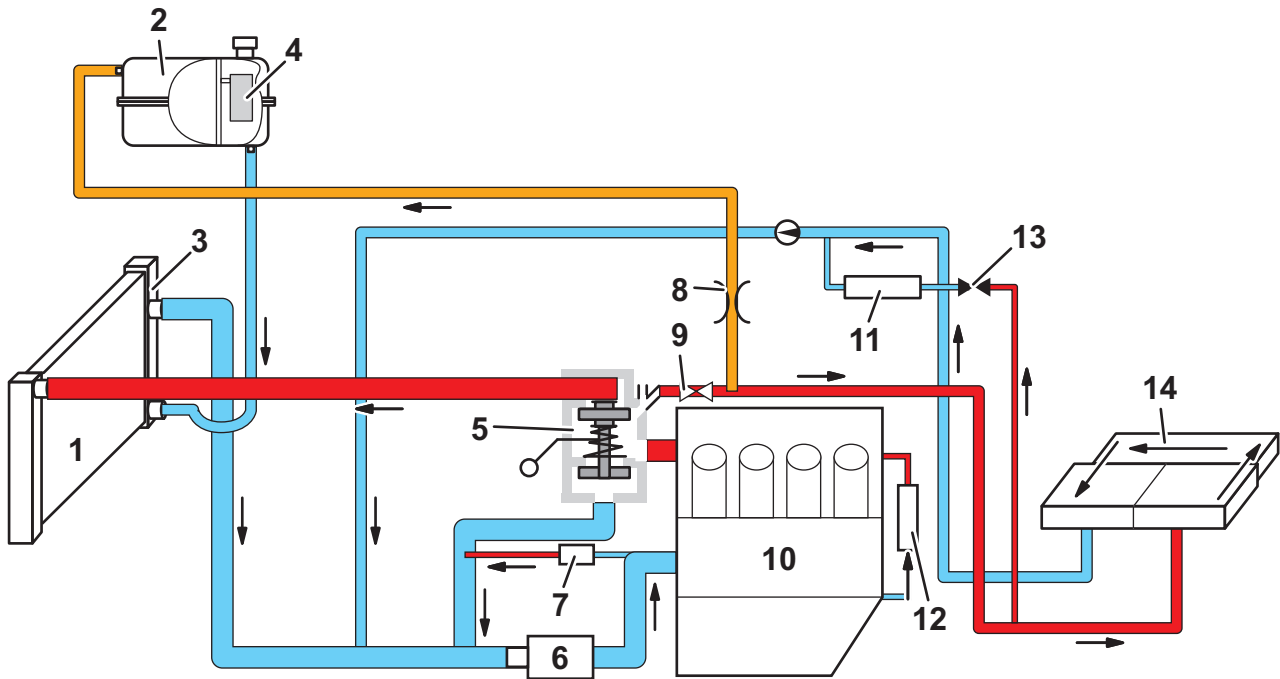

P20.00-2365-00

Overview of coolant circuit

- 1 Radiator
- 2 Expansion reservoir
- 3 Transmission cooler
- 4 Silica gel container
- 5 Two-disk thermostat with three-disk functionality
- 6 Coolant pump
- 7 Turbocharger
- 8 Throttle
- 9 Shutoff valve
- 10 Crankcase
- 11 Windshield washer fluid heater
- 12 Engine oil cooler
- 13 Duo-valve
- 14 Heater heat exchanger

- Coolant return
- Coolant feed
- Breather

Engine cooling

Radiator shutters

The radiator shutters control the flow of cooling air through the radiator and the engine compartment. With the reduced input of cooling air, aerodynamic drag decreases and fuel economy improves.

Controlled closing of the radiator shutters via the ME-SFI control unit reduces the amount of cooling of the engine compartment.

At the same time, closing the radiator shutters considerably reduces the external noise of the engine.

Operating principle

Adjustment of the radiator shutters is activated via a vacuum unit / adjusting element on the radiator housing. An actuator controlled by the ME-SFI control unit is actuated by a ground signal from the ME-SFI control unit after engine start. The vacuum coming from the brake booster builds up in the vacuum unit / adjusting element and the radiator shutters are closed via a linkage.

Note

When the coolant temperature reaches 106 °C, the radiator shutters are opened via a return spring. At 98 °C they are closed again via the adjusting element.

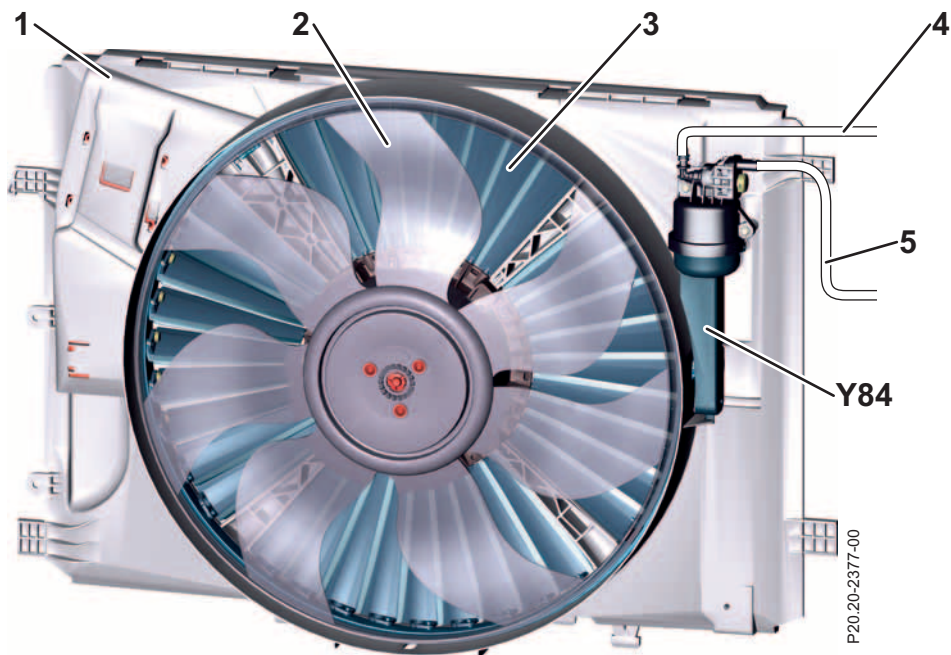

Radiator shutters

- 1 Radiator
- 2 Cooling fan
- 3 Radiator shutters
- 4 Vacuum line from brake booster
- 5 Signal line from ME-SFI control unit

Y84 Vacuum unit / adjuster element for radiator shutters (diagnosable)

Engine lubrication

Regulated oil pump

The oil circuit is supplied by a regulated oil pump. It offers high displacement in a small installation space and high efficiency.

The regulated oil pump is designed as a vane-type pump. With its infinitely variable delivery rate it is able to regulate the oil pressure.

Operating principle

The regulated oil pump is flange-mounted on the end face of the rear bearing seat of the Lanchester balancer housing and is driven by the intake-side balance shaft via a pair of gear wheels.

The oil pump is regulated on the clean-oil side. The oil is taken from the main oil duct and directed into the regulating chamber. In this regulating chamber the oil pushes against the spring-loaded set collar of the vane-type pump.

When the target pressure is reached in the main oil duct, the set collar is pushed against the spring force so that the eccentricity of the vane cell is reduced. This reduces the effective size of the oil pump and the delivery rate decreases so that the oil pressure cannot rise further.

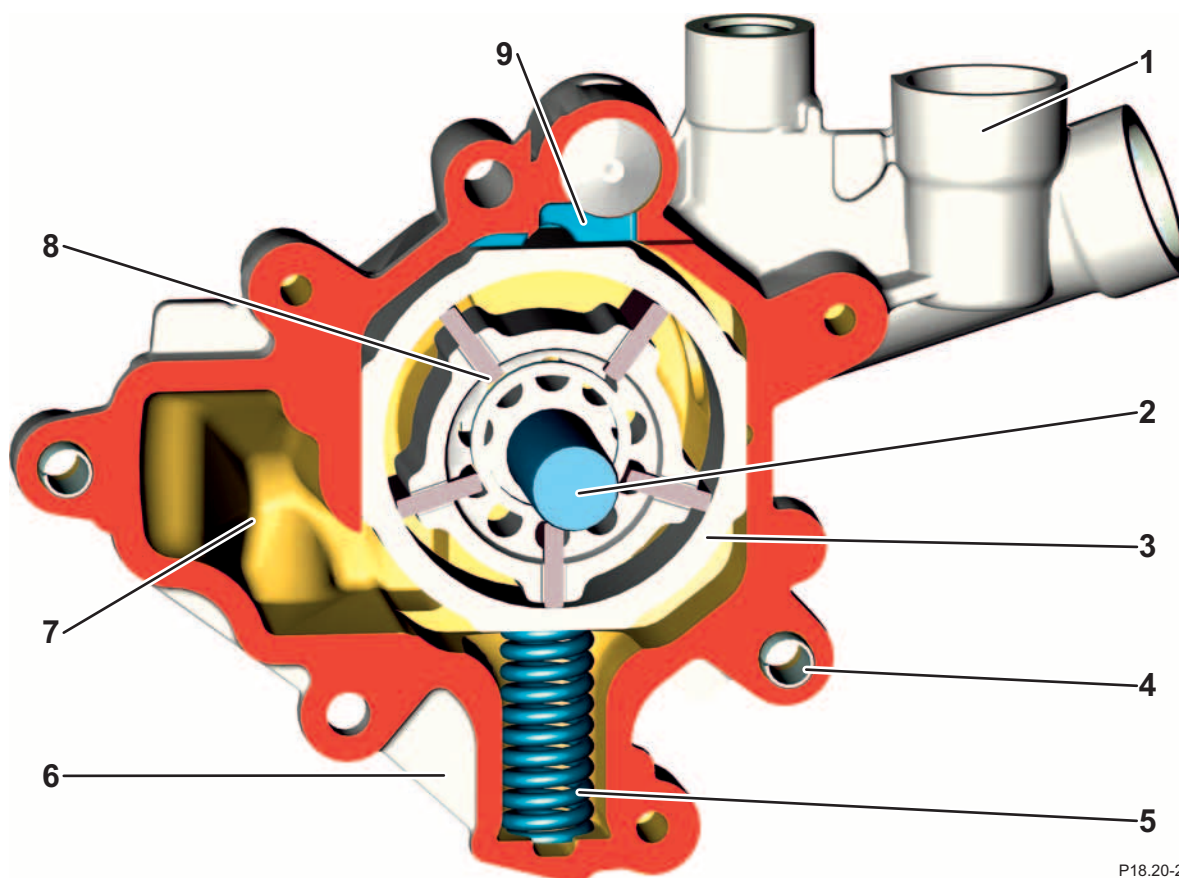

P18.20-2099-00

Regulated oil pump

- | | |
|---|------------------|
| 1 Pressure-side transfer point to crankcase | 6 Housing |
| 2 Drive | 7 Intake duct |
| 3 Set collar | 8 Vane cell |
| 4 Fitting sleeve | 9 Regulating oil |
| 5 Set collar spring | |

Oil level check switch

The oil level is registered by an oil level check switch, which transmits a signal to the ME-SFI control unit when the minimum oil level is reached. This information is forwarded to the instrument cluster via CAN (Controller Area Network) so that the customer is advised to check the oil level in good time before the lubrication becomes inadequate.

i Note

The oil level check switch is located in the bottom left-hand side of the engine oil pan at the transmission end.

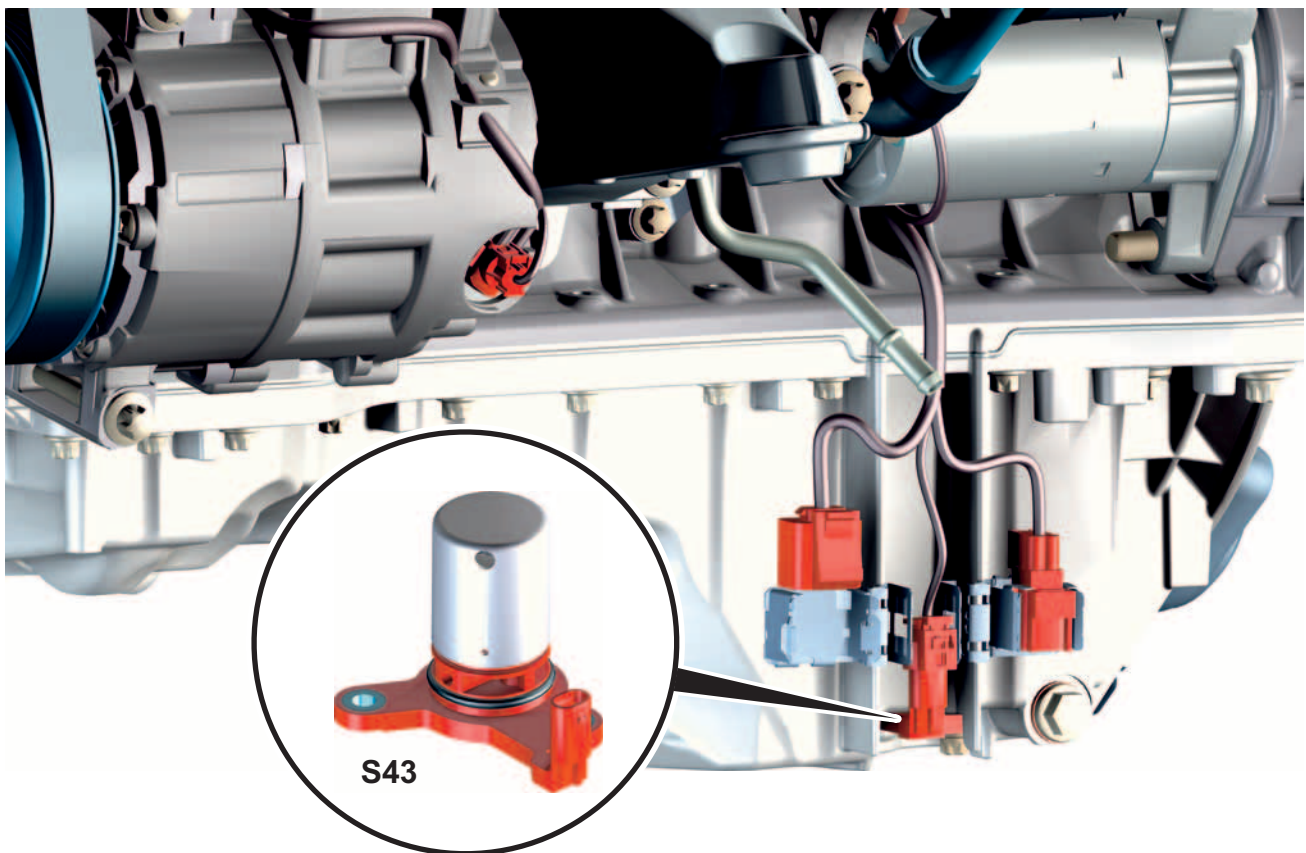

P18.40-2359-00

Oil level check switch

S43 Oil level check switch

Motor electronics control unit

The M 271 EVO features an advanced version of the electronic engine control SIM4KE20 of the M 271.

The expanded signals take into account the conversion to the turbocharger and the modification of the injection system for direct injection.

The control unit is integrated in the air filter on the M 271 EVO, which guarantees optimum cooling conditions.

For the change to the modified fuel injectors the hardware has been converted to high-voltage, quick-switching output stages which allow a dual injection strategy to be realized. This aids compliance with the Euro 5 standard.

The engine control of the M 271 EVO was planned as a modular platform for a wide variety of service conditions in various different model series, countries and power variants. For this reason the engine control was designed from the very beginning as a factory-flashable control unit.

Note

The universal hardware is programmed with software that has been specially tailored for the customer's vehicle with the appropriate data version in a flash station on the production line itself.

Note

The following page provides an overview of the electronic components which are described in detail in this Introduction into Service Manual.

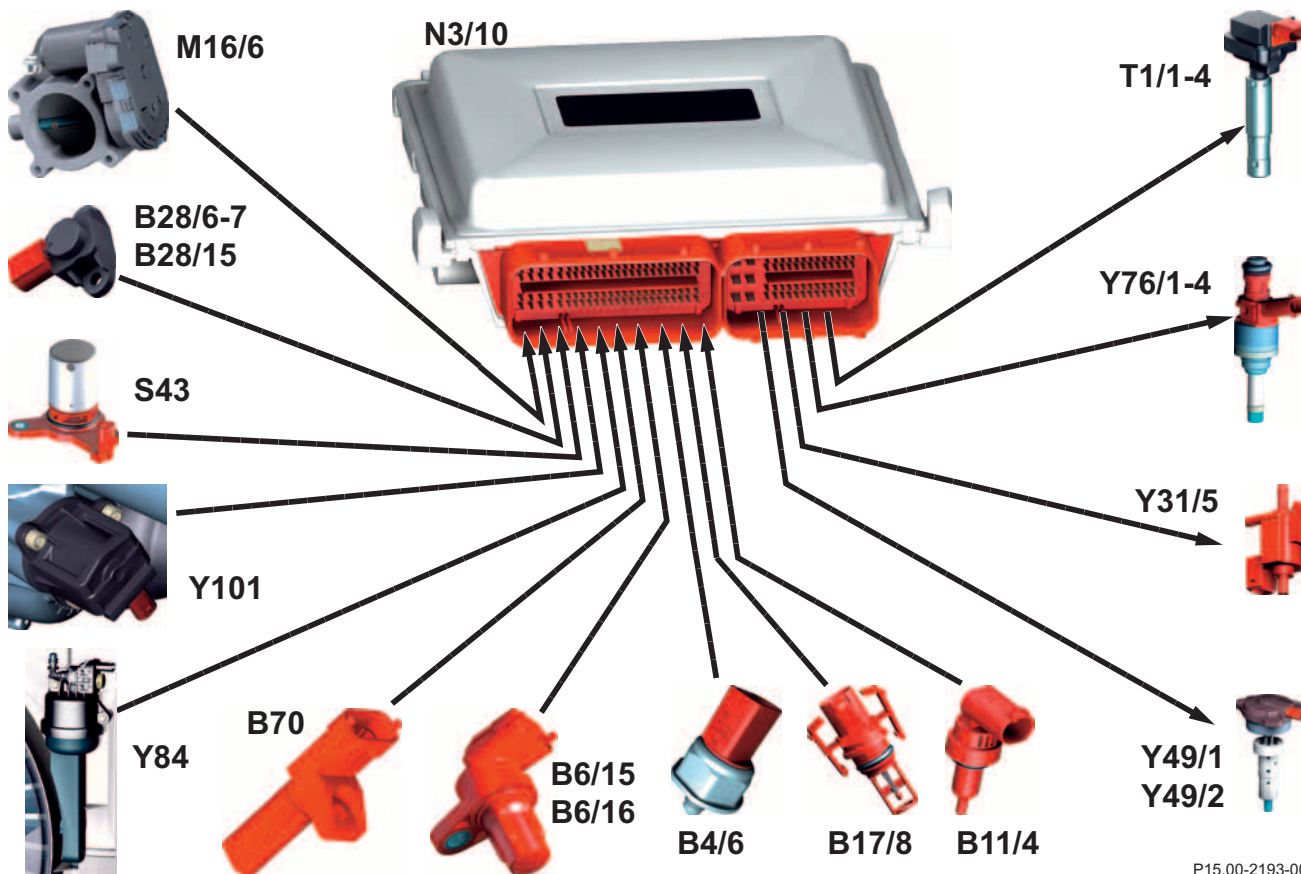

P15.00-2193-00

Overview

- N3/10 ME-SFI [ME] control unit
- M16/6 Throttle valve actuator
- B28/6 Pressure sensor upstream of throttle valve
- B28/7 Pressure sensor downstream of throttle valve
- B28/15 Pressure sensor upstream of compressor impeller
- S43 Oil level check switch
- Y101 Blow-off valve
- Y84 Vacuum unit/adjuster element for radiator shutters (diagnosable)
- B70 Crankshaft Hall sensor
- B6/15 Intake camshaft Hall sensor
- B6/16 Exhaust camshaft Hall sensor
- B4/6 Rail pressure sensor
- B17/8 Charge air temperature sensor
- B11/4 Coolant temperature sensor
- Y49/1 Intake camshaft solenoid
- Y49/2 Exhaust camshaft solenoid
- Y31/5 Boost pressure control pressure transducer
- Y76/1-4 Fuel injector, cylinders 1-4
- T1/1-4 Ignition coil, cylinders 1-4

Motor electronics control unit

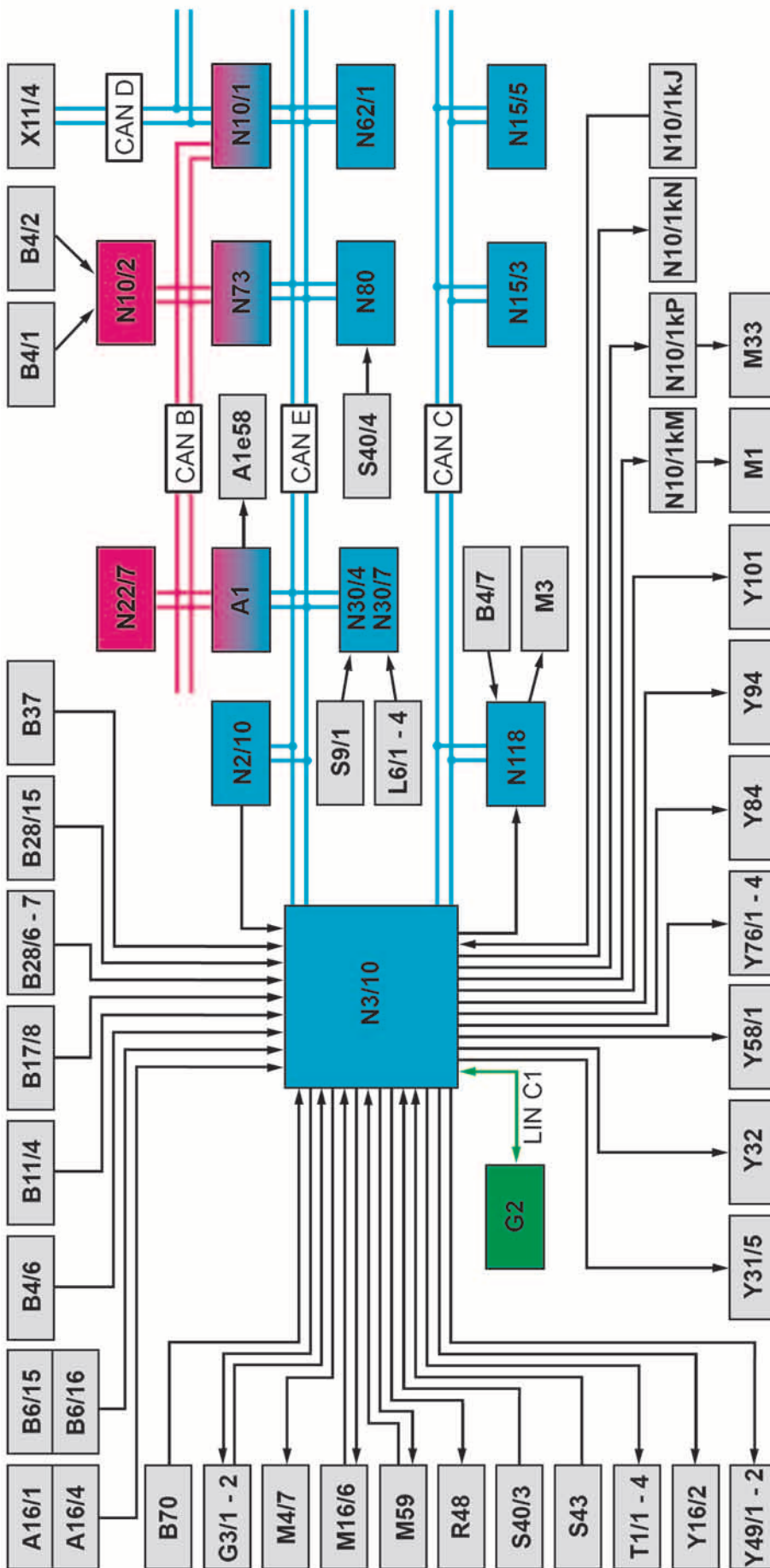

P07-70-2179-79

Block diagram

A1	Instrument cluster	N3 / 10	ME-SFI [ME] control unit
A1e58	Engine diagnosis indicator lamp	N10 / 1	Front SAM control unit with fuse and relay module
A16 / 1	Rear knock sensor	N10 / 1KJ	Circuit 15 relay
A16 / 4	Front knock sensor	N10 / 1KM	Circuit 50 relay, starter
B4 / 1	Fuel level indicator sensor, left	N10 / 1KN	Circuit 87 relay, engine
B4 / 2	Fuel level indicator sensor, right	N10 / 1KP	Secondary air injection relay
B4 / 6	Rail pressure sensor	N10 / 2	Rear SAM control unit with fuse and relay module
B4 / 7	Fuel pressure sensor	N15 / 3	Electronic transmission control control unit
B6 / 15	Intake camshaft Hall sensor	N15 / 5	(with code (423) 5-speed automatic transmission (NAT)) Electronic selector lever module control unit
B6 / 16	Exhaust camshaft Hall sensor	N22 / 7	(with code (423) 5-speed automatic transmission (NAT)) Automatic air conditioning control and operating unit
B11 / 4	Coolant temperature sensor	N30 / 4	Electronic Stability Program control unit (except code (233) DISTRONIC PLUS)
B17 / 8	Charge air temperature sensor	N30 / 7	Electronic Stability Program Premium control unit (with code (233) DISTRONIC PLUS)
B28 / 6	Pressure sensor upstream of throttle valve	N62 / 1	Radar sensors control unit (with code (233) DISTRONIC PLUS)
B28 / 7	Pressure sensor downstream of throttle valve	N73	Electronic ignition lock control unit
B28 / 15	Pressure sensor upstream of compressor impeller	N80	Steering column tube module control unit
B37	Accelerator pedal sensor	N118	Fuel pump control unit
B70	Crankshaft Hall sensor	R48	Coolant thermostat heating element
CAN B	Interior CAN	S9 / 1	Brake light switch
CAN C	Drivetrain CAN	S40 / 3	Clutch pedal switch (with manual transmission)
CAN D	Diagnostic CAN	S40 / 4	Cruise control lever
CAN E	Chassis CAN	S43	Oil level check switch
G2	Alternator	T1 / 1-4	Ignition coil, cylinders 1-4
G3 / 1	Oxygen sensor downstream of catalytic converter	X11 / 4	Diagnostic connector
G3 / 2	Oxygen sensor upstream of catalytic converter	Y16 / 2	Heating system shutoff valve
L6 / 1	Left front axle rpm sensor	Y31 / 5	Boost pressure control pressure transducer
L6 / 2	Right front axle rpm sensor	Y32	Air pump switchover valve
L6 / 3	Left rear axle rpm sensor	Y49 / 1	Intake camshaft solenoid
L6 / 4	Right rear axle rpm sensor	Y49 / 2	Exhaust camshaft solenoid
LIN C1	Drivetrain LIN	Y58 / 1	Purge control valve
M1	Starter	Y76 / 1-4	Fuel injector, cylinders 1-4
M3	Fuel pump	Y84	Vacuum unit / adjuster element for radiator shutters (diagnosable)
M4 / 7	Engine and air conditioning fan motor with integrated control	Y94	Quantity control valve
M16 / 6	Throttle valve actuator	Y101	Blow-off switchover valve
M33	Electric air pump		
M59	Intake manifold swirl flap actuator motor		
N2 / 10	Supplemental restraint system control unit		

Ignition system

Ignition coils

Single-spark ignition coils are used in the M 271 EVO.

Each cylinder has its own ignition coil, actuated and controlled by the ME-SFI control unit.

In all operating states (start-up, wide open throttle, partial load, deceleration mode) corrections can be made to the ignition angle whenever external variables (e.g. engine temperature, intake air temperature, battery voltage) make this necessary.

The ignition map is generally adjusted according to the following criteria:

- Reduction in fuel consumption
- Pollutant reduction
- Increase in torque at low rpm
- Power increase
- Improvement in engine smooth running characteristics

Additional functions integrated in the ME-SFI control unit are:

- Idle speed control
- Rpm limitation (variable)
- Knock control
- Limp-home mode
- Sensor monitoring
- Self-diagnosis

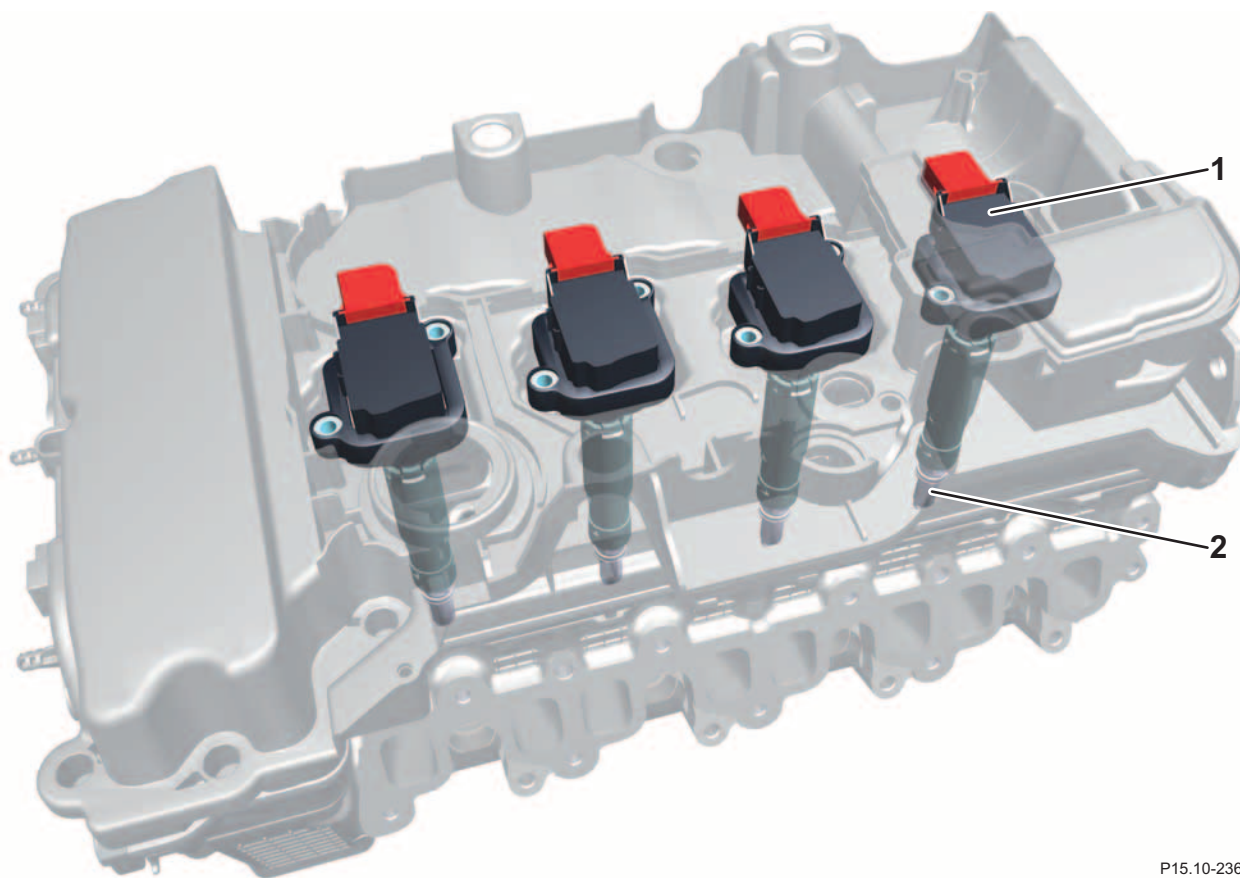

P15.10-2368-00

Location of ignition coils

- 1 Ignition coil
- 2 Spark plug

ECO start/stop system

On its market launch in September 2009, the M 271 EVO will be equipped with an ECO start / stop system, initially only in combination with the manual transmission.

Operating principle

The ECO start / stop system allows the engine to be shut off at very low speeds and while stationary provided that certain vehicle-dependent and driver-related conditions are met (autostop function).

In this way, fuel consumption is further reduced.

The starter can perform an automatic restart (autostart function) as soon as necessary. The ECO start / stop system employs a crankshaft Hall sensor with direction detection and a modified starter.

The ME-SFI control unit uses the modified crankshaft Hall sensor to detect the position of the crankshaft. This means that, when the engine is restarted, a reduced fuel quantity can be injected directly in the first cylinder in order to guarantee a rapid starting procedure, e.g. at traffic lights.

Function requirements

In order to perform an autostop with the aid of the ECO start / stop system, the following requirements must be satisfied:

- 1 The engine has achieved the necessary operating parameters (e.g. the minimum required coolant temperature).
- 2 The following driver-related conditions are met:
 - The transmission is in neutral.
 - The clutch and accelerator pedal are not operated.
 - The service brake is applied.
 - The vehicle speed is below a limit speed.
- 3 The ECO start / stop system has not been switched off with the ECO button (the default after initial start-up is the ON state).
- 4 After a key start or e.g. maneuvering, appropriate limit speeds have been exceeded.
- 5 The vehicle-dependent conditions of the following systems are met:
 - Air conditioning
 - On-board electrical system
 - Brake system
 - Suspension
 - Other sensor systems, such as the door locks, seat belt buckles and engine hood contacts



ECO button with indicator lamp

P54.25-8174-00

ECO start/stop system

Primary functions

The ECO start / stop system consists of the following primary functions:

- Engine stop function
- Engine start function
- Forced engine start

Engine stop function

The engine is switched off by the ME-SFI control unit when the following function conditions are satisfied:

- The transmission is in neutral.
- The clutch and accelerator pedal are not operated.
- The service brake is applied.
- The vehicle speed is below a limit speed.

Engine start function

An automatic engine start occurs when the engine is at autostop, i.e. the engine was switched off via the engine stop function and the circuit 15 voltage (ignition ON) is still present.

For this, one of the following function conditions must be satisfied:

- Accelerator pedal is operated.
- The clutch is operated.
- The ECO start / stop system is switched off via the ECO button.
- The vehicle speed is above a limit speed.
- A function that requires the engine to be running, such as a vehicle level increase, is activated by the driver.

To restart the engine, the ME-SFI control unit requests a restart (autostart).

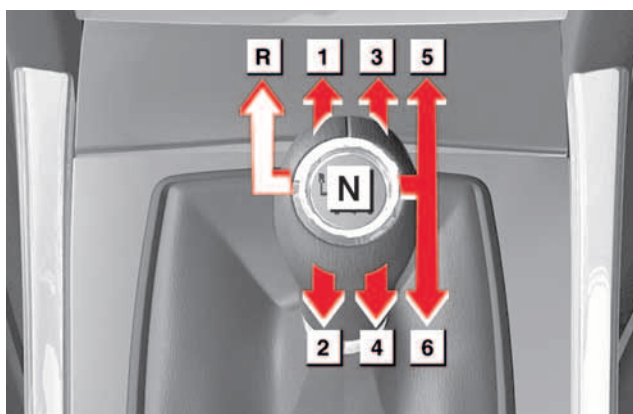

P26.60-2420-00

**Shift pattern in vehicles with
ECO start/stop system**

ECO start/stop system

Forced engine start

Another form of automatic engine start is available as a protection function, namely the forced engine start. This requires that the drive train is open.

The engine is started automatically by the ME-SFI control unit without intervention from the driver when one of the following function conditions is met:

- 1 The driver unfastens the seat belt or opens the driver door.
- 2 A vehicle-related condition in one of the following systems is no longer satisfied:
 - Air conditioning
 - On-board electrical system
 - Brake system
 - Suspension
 - Other sensor systems

Instrument cluster displays

In vehicles with ECO start / stop system, additional messages are stored in the multifunction display of the instrument cluster. The ECO symbol announces the availability of the autostop function to the driver.



P54.32-7820-00

ECO symbol in multifunction display

i Note

Further details on these and other electrical systems (e.g. function descriptions and the locations of electrical components) are available in the Workshop Information System (WIS) under "Basic knowledge / functions" (GF).

Engine

Open end wrench

Use The open end wrench enables the Lanchester balancer shafts to be positioned so that the mounting bolts can be loosened and tightened.

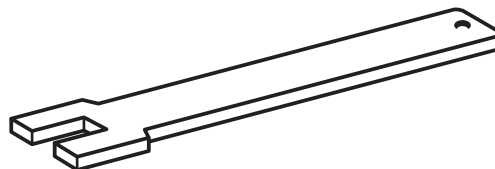

P58.20-2260-00

Part number W271 589 01 01 00

FG 01

Set C

Extractor

Use The extractor is used to extract seized fuel injectors.

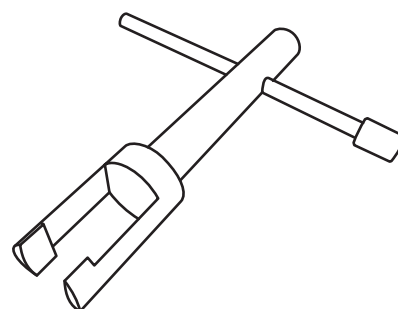

P58.20-2261-00

Part number W271 589 02 33 00

FG 07

Set B

Note Only in combination with:
Impact extractor W602 589 00 33 00



Assembly tool

Use	The assembly tool is used to install and calibrate the teflon ring on the fuel injector.
Part number	W271 589 01 43 00
FG	07
Set	B

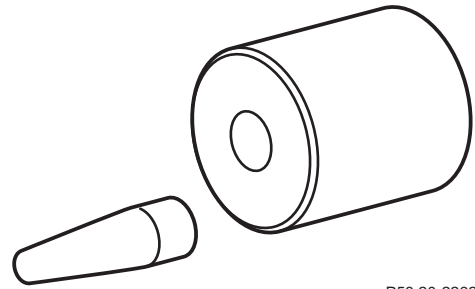

P58.20-2262-00

Tester cap

Use	The oil pressure is used to check the oil pressure at the oil filter housing insert.
Part number	W271 589 04 63 00
FG	18
Set	B
Note	Only in combination with: Tester W103 589 00 21 00

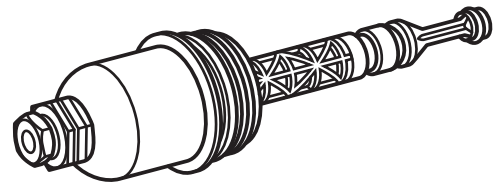

P58.20-2263-00

Engine

Assembly attachments

Use	The assembly attachments are used to press on the outer tabs and to rivet the bush chain.
Part number	W271 589 05 63 00
FG	05
Set	C
Note	Consisting of chain guide F13 and D16 and centering fork (2 ea.). Only in combination with: Riveting and assembly tool W642 589 00 33 00

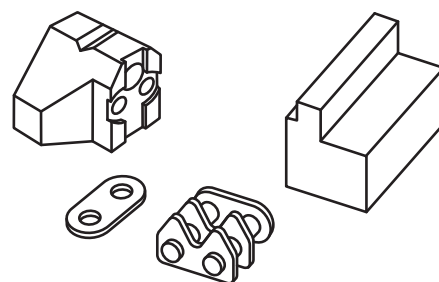

P58.20-2264-00

Guide plate

Use	The guide plate is used as a guide when pressing down the valve springs.
Part number	W271 589 06 63 00
FG	05
Set	B
Note	Only in combination with: Valve assembly tool kit W111 589 25 61 00

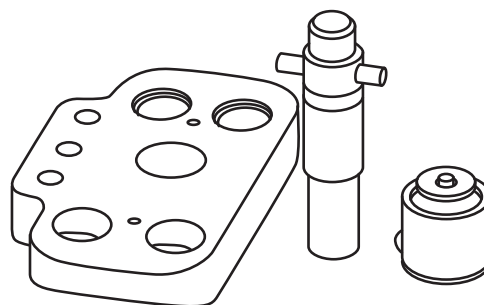

P58.20-2265-00



Connection adapter

Use	The connection adapter is used for leak testing of the charge air system.
Part number	W271 589 01 91 00
FG	09
Set	B
Note	Only in combination with: Leak tester W611 589 02 21 00

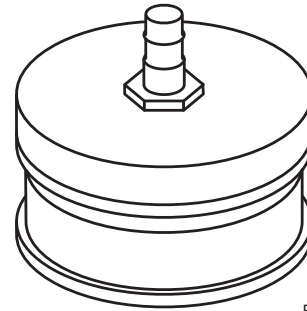

P58.20-2266-00

Abbreviations

CAN

Controller Area Network

CO

Carbon monoxide

CO₂

Carbon dioxide

HC

Hydrocarbons

H₂O

Water

LIN

Local interconnect network

ME

Motor electronics (ME-SFI)

O₂

Oxygen

SAM

Signal acquisition and actuation module

WIS

Workshop Information System

A		F	
Afterburning	34	Forced induction	22
Air pump switchover valve	35	Fuel high-pressure pump	20
Air shutoff valve of secondary air injection pump	35	Fuel high-pressure sensor	20
Assembly attachments	52	Fuel injectors	19
Assembly tool	51	Fuel system	21
		Full load ventilation	13
B		G	
Belt drive	17	Guide plate	52
Block diagram	44	H	
Blow-off valve	29	High-pressure system.	20
BlueEFFICIENCY.	6	Homogeneous direct injection	18
Boost pressure control	25		
Boost pressure control flap	25	I	
Boost pressure control pressure transducer	26	Ignition coils	46
Brief description.	6	Ignition system	46
C		Injection technology	18
Camshaft adjuster.	11	Injectors	19
Chain drive	14	Input and output signals	42
Charge air manifold	30	Intake manifold	30
Connection adapter	53		
Coolant circuit.	37	L	
Coolant thermostat	36	Lambda control	32
Cooling system	36	Lanchester balancer	16
Crank assembly	16	Low-pressure system	21
Crankcase ventilation	12		
Cyclone oil separator	12	N	
Cylinder head	10	New features	7
Cylinder head and engine control.	10		
E		O	
ECO start / stop system	47	Oil level check switch	41
Electric secondary air injection pump.	34	Oil level switch	41
Engine control.	10	Oil pump	40
Engine cooling.	36	Open end wrench	50
Engine data	9	Oxygen sensor downstream of catalytic converter	33
Engine lubrication	40	Oxygen sensor upstream of catalytic converter	33
Engine views	8		
Exhaust system	33		
Extractor	50		

P

Partial load ventilation	12
Performance graph	9
Poly-V belt	17
Pressure sensors	27

Q

Quantity control valve	20
----------------------------------	----

R

Radiator shutters	38
Rail	18
Rail pressure sensor	20
Regulated oil pump	40

S

Secondary air injection	34
Simplex bush chain	14
Single-spark ignition coils	46
Special tools	50
Start/stop system	47
Starter	47
Swirl flap control	30

T

Technical data	9
Tester cap	51
Three-disk thermostat	36
Toothed bush chain	14
Turbocharger	22

W

Wastegate	25
---------------------	----



