

MODEL 212, 207

Shown on model 212

- 1 Front center reinforcement
- 2 Reinforcement, outer right
- 3 Reinforcement, outer left
- 4 Striker
- 5 Front crossmember
- 6 Absorber, right
- 7 Absorber, left
- 8 Strut, right
- 9 Strut, left
- 10 Right support
- 11 Left support

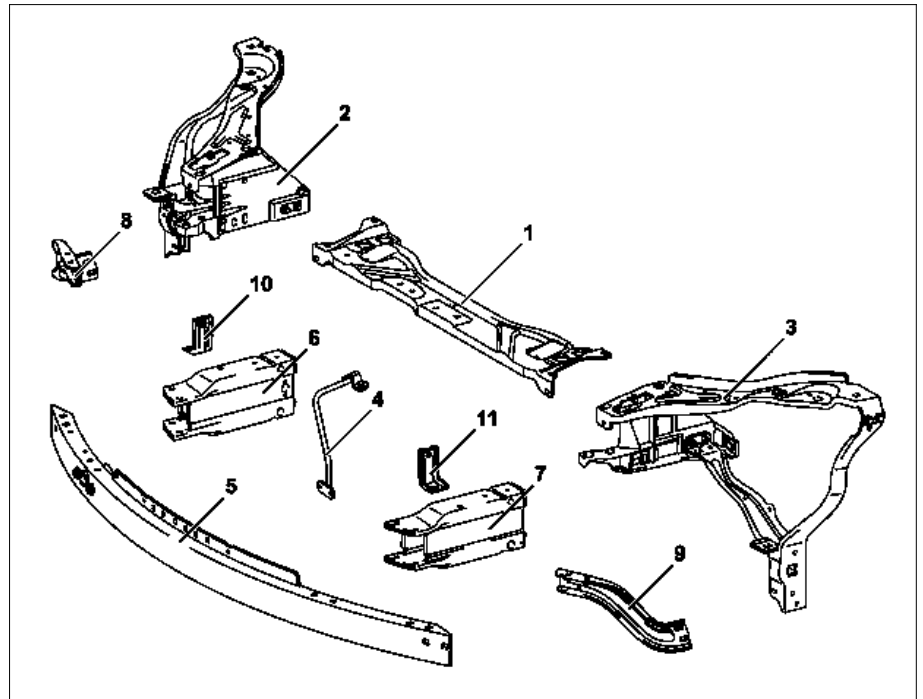

P62.30-2969-06

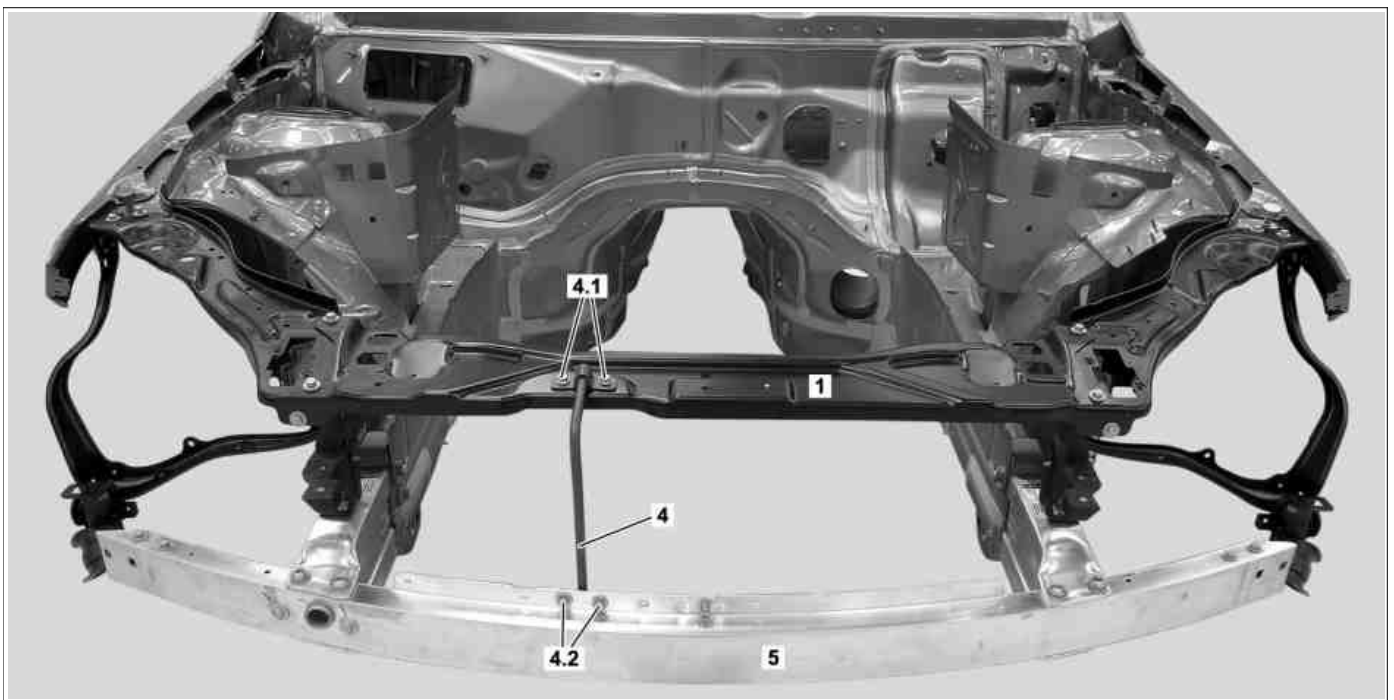

P62.30-2970-09

Shown on model 212

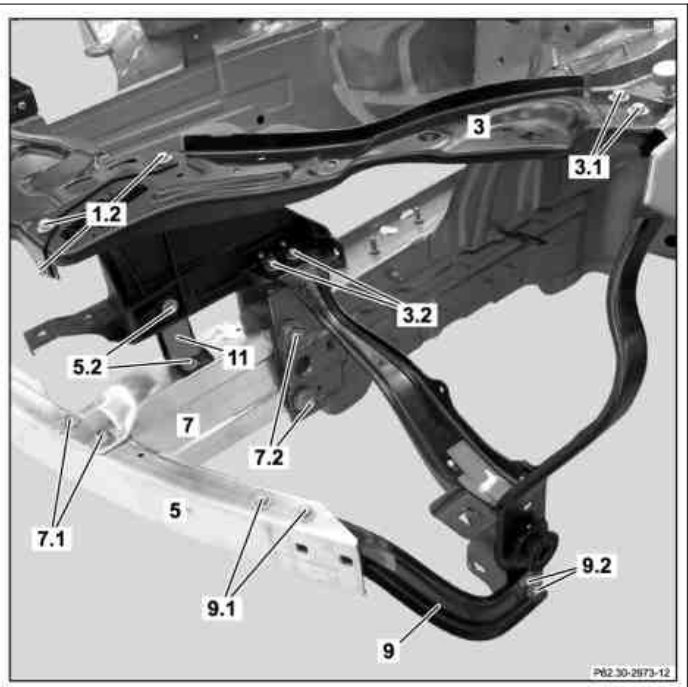
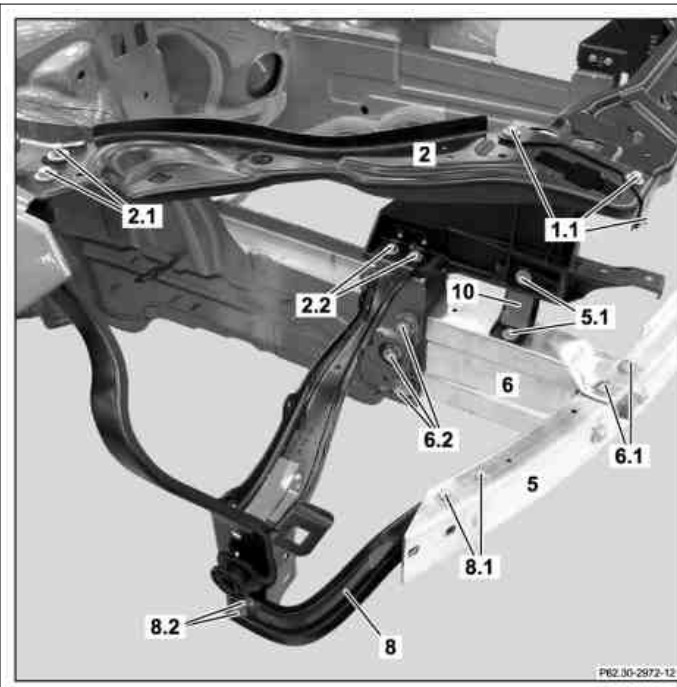

P62.30-2971-09

Shown on model 212

☒ ☒	Remove/install		
⚠ Danger!	Risk of death caused by vehicle slipping or toppling off of the lifting platform.	Align vehicle between columns of vehicle lift and position four support plates at vehicle lift support points specified by vehicle manufacturer.	AS00.00-Z-0010-01A
⚠ Danger!	Risk of injury caused by scraping or cutting body parts on sharp vehicle parts	Always wear protective gloves when working on or near sharp and non-deburred vehicle parts. Deburr repair panels.	AS00.00-Z-0017-01A
ⓘ	General information on body repair		AH60.00-N-0001-01A
1	Remove all detachable parts in repair area.		
2	Unscrew bolts (4.1, 4.2) and remove striker (4)		
3	Unscrew bolts (1.1, 1.2) and remove center front reinforcement (1)		
4	Unscrew bolts (8.1, 8.2, 9.1, 9.2) and remove struts (8, 9)	ⓘ On model 207 bolts (8.1 and 9.1) are located at the front of the front crossmember (5)	
5	Unscrew bolts (5.1, 5.2) and remove supports (10, 11)		
6	Unscrew bolts (2.1, 2.2, 3.1, 3.2) and remove outer reinforcement (2, 3)		
7	Unscrew bolts (6.1, 7.1) and remove front crossmember (5)	ⓘ Installation: Tighten bolts (6.1, 7.1) with specified torque before installing headlamp.	
8	Unscrew bolts (6.2, 7.2) and remove absorber (6, 7)	Nm Bolt, crossmember mount to absorber	*BA62.30-P-1002-02G
9	Install in the reverse order		
10	Adjust gap dimensions on hoods, doors and lids	Model 212 ☑ Feeler gauge	AR60.00-P-0700-01EW
11	Fit front end assembly with reinforcement	Model 207 ☑ Feeler gauge ⓘ Fit headlamp unit and bumper for adjustment work.	*129589032100 *BE60.00-P-1001-01U AR60.00-P-0700-01EC *129589032100 *BE60.00-P-1001-01W
11	Fit front end assembly with reinforcement	ⓘ Remove bumper after adjustment work. Nm Bolt, absorber mount on longitudinal member Nm Bolt, striker bracket	*BA62.30-P-1001-02G *BA62.30-P-1003-02G

12	Apply wax preservation to connections on body	i After adjustment operations as well as removal and installation of front end assembly parts with reinforcement. Preservation agent	*BR00.45-Z-1003-05A
----	---	--	---------------------

Check values for gaps

Number	Designation			Model 212.0/1	Model 212.2	
BE60.00-P-1001-01U	Gap dimension	Engine hood to fender	Dimension "A"	mm	4 (±1)	4 (±1)
		Engine hood to headlamp	Dimension "B"	mm	4 (±1)	4 (±1)
		Engine hood to radiator grille	Dimension "C"	mm	-	-
		Engine hood to bumper	Dimension "D"	mm	4.5 (±1.5)	4.5 (±1.5)
		Engine hood to A-pillar	Dimension "E"	mm	4.5 (±1.5)	4.5 (±1.5)
		Bumper to headlamp	Dimension "F"	mm	3.5 (±1.5)	3.5 (±1.5)
			See picture		AR60.00-P-0700-01EW	AR60.00-P-0700-01EW

Check values for gaps

Number	Designation			Model 207.3	Model 207.4	
BE60.00-P-1001-01W	Gap dimension	Engine hood to fender	Dimension "A"	mm	4 (±1)	4 (±1)
		Engine hood to headlamp	Dimension "B"	mm	4 (±1)	4 (±1)
		Engine hood to bumper	Dimension "C"	mm	6 (+1/-2)	6 (+1/-2)
		Engine hood to A-pillar	Dimension "D"	mm	4.5 (+2/-1)	4.5 (+2/-1)
		Bumper to headlamp	Dimension "E"	mm	2.5 (±1.5)	2.5 (±1.5)
			See picture		AR60.00-P-0700-01EC	AR60.00-P-0700-01EC

Nm Front end assembly with front reinforcement

Number	Designation			Model 207.3	Model 207.4
BA62.30-P-1001-02G	Bolt, absorber mount on longitudinal member	Stage 1	Nm	90	90
		Stage 2	∠°	90	90

BA62.30-P-1002-02G	Bolt, crossmember mount on absorber	Stage 1	Nm	28	28
		Stage 2	∟°	135	135
BA62.30-P-1003-02G	Bolt for attaching striker		Nm	10	10

Nm Front end assembly with front reinforcement

Number	Designation			Model 212
BA62.30-P-1001-02G	Bolt, absorber mount on longitudinal member	Stage 1	Nm	90
		Stage 2	∟°	90
BA62.30-P-1002-02G	Bolt, crossmember mount on absorber	Stage 1	Nm	28
		Stage 2	∟°	135
BA62.30-P-1003-02G	Bolt for attaching striker		Nm	10

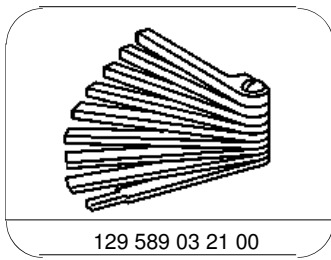

Feeler gauge

Repair materials

Number	Designation	Order number
BR00.45-Z-1003-05A	Cavity sealant, solvent-free (1 l container)	A 000 986 72 70 05