

Document number: pe72.29-p-2108-97iaa

Document title: Wiring diagram for left and right front door control unit (DCU (TSG))

Code:	Designation:	Position:
A0	Color code key	104L
A26/1	Driver door infrared remote control receiver	86L
A85	Left front door lock	89L
A85	Left front door lock	93L
A85/1	Right front door lock	89L
A85/1	Right front door lock	93L
A85/1m1	Right front door central locking motor	88L
A85/1m1	Right front door central locking motor	92L
A85/1m4	Right front door additional door lock actuator motor	94L
A85/1s1	Right front door rotary tumbler switch	90L
A85/1s1	Right front door rotary tumbler switch	93L
A85m1	Left front door central locking motor	88L
A85m1	Left front door central locking motor	92L
A85m4	Left front door additional door lock actuator motor	94L
A85s1	Left front door rotary tumbler switch	90L
A85s1	Left front door rotary tumbler switch	94L
CAN B	Interior CAN	3K
CAN B	Interior CAN	7K
Code 275	Memory package (driver seat, mirrors)	26F
Code 877	Ambiance illumination	48D
Code 880	Locking system with infrared remote control	84B
Code 885	Increased theft protection	91B
Code 890	Automatic rear-end door	76D
Code U62	Exterior light and vision package	36D
Code U62	Exterior light and vision package	43D
E17/11	Left front door door handle illumination	44L
E17/11	Left front door door handle illumination	50L
E17/12	Right front door door handle illumination	44L
E17/12	Right front door door handle illumination	50L
E17/3	Left front door exit and warning lamp	37L
E17/3	Left front door exit and warning lamp	41L
E17/4	Right front door exit and warning lamp	37L
E17/4	Right front door exit and warning lamp	41L
E17/43	Left front door ambiance illumination	47L
E17/43	Left front door ambiance illumination	54L
E17/44	Right front door ambiance illumination	47L
E17/44	Right front door ambiance illumination	54L
E6/5	Left outside mirror turn signal lamp	18L
E6/5x1	Left outside mirror turn signal lamp electrical connector	18G
E6/6	Right outside mirror turn signal lamp	18L
E6/6x1	Right outside mirror turn signal lamp electrical connector	18H
F34	Vehicle interior fuse box	16K
F34f23	Fuse 23	
F34f24	Fuse 24	16L
M10/3	Left front door power window motor	82L
M10/4	Right front door power window motor	82L
M21/1	Left outside mirror	27L
M21/1e1	Left outside mirror ambient lamp	32L
M21/1e2	Left Blind Spot Assist readiness and warning indicator	34L
M21/1h1	Automatic dimming mirror	22L
M21/1m1	Vertical inclination adjustment actuator motor	25J
M21/1m2	Horizontal inclination adjustment actuator motor	25K
M21/1m3	Outside mirror fold-in/fold-out electric motor	30L
M21/1r1	Mirror heater	20L
M21/1r2	Vertical inclination adjustment potentiometer	28J
M21/1r3	Horizontal inclination adjustment potentiometer	28K
M21/1x1	Left outside mirror electrical connector	21G

Document number: pe72.29-p-2108-97iaa

Document title: Wiring diagram for left and right front door control unit (DCU (TSG))

Code:	Designation:	Position:
M21/1x1	Left outside mirror electrical connector	34G
M21/2	Right outside mirror	27L
M21/2e1	Right outside mirror ambient lamp	32L
M21/2e2	Right Blind Spot Assist readiness and warning indicator	34L
M21/2h1	Automatic dimming mirror	22L
M21/2m1	Vertical inclination adjustment actuator motor	25K
M21/2m2	Horizontal inclination adjustment actuator motor	25K
M21/2m3	Outside mirror fold-in/fold-out electric motor	30L
M21/2r1	Mirror heater	20L
M21/2r2	Vertical inclination adjustment potentiometer	28J
M21/2r3	Horizontal inclination adjustment potentiometer	28K
M21/2x1	Right outside mirror electrical connector	21H
M21/2x1	Right outside mirror electrical connector	33H
N10	SAM control unit	3L
N69/1	Left front door control unit	12A
N69/1	Left front door control unit	4A
N69/1	Left front door control unit	36A
N69/1	Left front door control unit	21A
N69/1	Left front door control unit	29A
N69/1	Left front door control unit	44A
N69/1	Left front door control unit	52A
N69/1	Left front door control unit	60A
N69/1	Left front door control unit	68A
N69/1	Left front door control unit	76A
N69/1	Left front door control unit	86A
N69/1	Left front door control unit	93A
N69/2	Right front door control unit	11A
N69/2	Right front door control unit	4A
N69/2	Right front door control unit	36A
N69/2	Right front door control unit	21A
N69/2	Right front door control unit	29A
N69/2	Right front door control unit	44A
N69/2	Right front door control unit	52A
N69/2	Right front door control unit	60A
N69/2	Right front door control unit	68A
N69/2	Right front door control unit	76A
N69/2	Right front door control unit	86A
N69/2	Right front door control unit	93A
N73	Electronic ignition switch control unit	12L
S15/1	Trunk lid release button	74L
S15/3	Driver trunk lid/liftgate control button	78L
S20	Driver-side power window and outside mirror adjustment switch group	63L
S20s1	Left front power window switch	62J
S20s10	Left outside mirror adjustment switch	66K
S20s11	Right outside mirror adjustment switch	66J
S20s12	Outside mirror adjustment switch	64K
S20s2	Right front power window switch	62K
S20s3	Left rear power window switch	63J
S20s4	Right rear power window switch	63K
S20s5	Rear side window child safety lock switch	64J
S20s9	Outside mirror fold-in/fold-out switch	65K
S21/2	Passenger-side power window switch	71L
S22	Left front seat adjustment switch group	58L
S23	Right front seat adjustment switch group	58L
S85/5	Left front door central locking interior switch	68L
S85/6	Right front door central locking interior switch	68L
U10	Valid for left door	1A

Document number: pe72.29-p-2108-97iaa

Document title: Wiring diagram for left and right front door control unit (DCU (TSG))

Code:	Designation:	Position:
U1084	Valid for outside mirror ambient lamps	31D
U11	Valid for right door	1A
U14	Valid for driver-side door	1J
U14	Valid for driver-side door	10G
U14	Valid for driver-side door	21D
U14	Valid for driver-side door	60D
U14	Valid for driver-side door	73D
U14	Valid for driver-side door	76D
U14	Valid for driver-side door	84B
U144	Valid for outside mirror fold-in/out function	29D
U144	Valid for outside mirror fold-in/out function	65J
U15	Valid for passenger-side door	1H
U15	Valid for passenger-side door	5H
U15	Valid for passenger-side door	69D
U394	Valid without code (877) Ambiance illumination	43D
U71	Valid for fully electric seat adjustment with memory function	23D
U71	Valid for fully electric seat adjustment with memory function	57D
U76	Valid for automatic dimming mirror	21D
U910	Valid for Blind Spot Assist	33D
U933	Not valid for CODE 885 Increased theft protection	88B
W15/1	Right footwell A-pillar ground point	14H
W15/2	Left footwell ground point	14H
X157/6	Right front door ambiance illumination electrical connector	44J
X157/6	Right front door ambiance illumination electrical connector	49J
X157/6	Right front door ambiance illumination electrical connector	52J
X157/6	Right front door ambiance illumination electrical connector	46J
X157/7	Left front door ambiance illumination electrical connector	44H
X157/7	Left front door ambiance illumination electrical connector	46H
X157/7	Left front door ambiance illumination electrical connector	49J
X157/7	Left front door ambiance illumination electrical connector	52J
X30/32	Interior CAN (CAN B) potential distributor electrical connector	7L
X35/1	Driver door electrical connector	14F
X35/1	Driver door electrical connector	4F
X35/2	Front passenger door electrical connector	13G
X35/2	Front passenger door electrical connector	4F
Z232/10z1	Left front door ambiance illumination connector sleeve (red)	49F
Z232/10z3	Right front door ambiance illumination connector sleeve (red)	49G
Z232/8z1	Left front door ambiance illumination connector sleeve (yellow)	53F
Z232/8z3	Right front door ambiance illumination connector sleeve (yellow)	53F
Z232/9z1	Left front door ambiance illumination connector sleeve (blue)	55F
Z232/9z3	Right front door ambiance illumination connector sleeve (blue)	55F
Z52/15z1	Exit and warning lamp connector sleeve	39G
Z52/15z2	Exit and warning lamp connector sleeve	41G
Z52/15z3	Exit and warning lamp connector sleeve	39G
Z52/15z4	Exit and warning lamp connector sleeve	41G

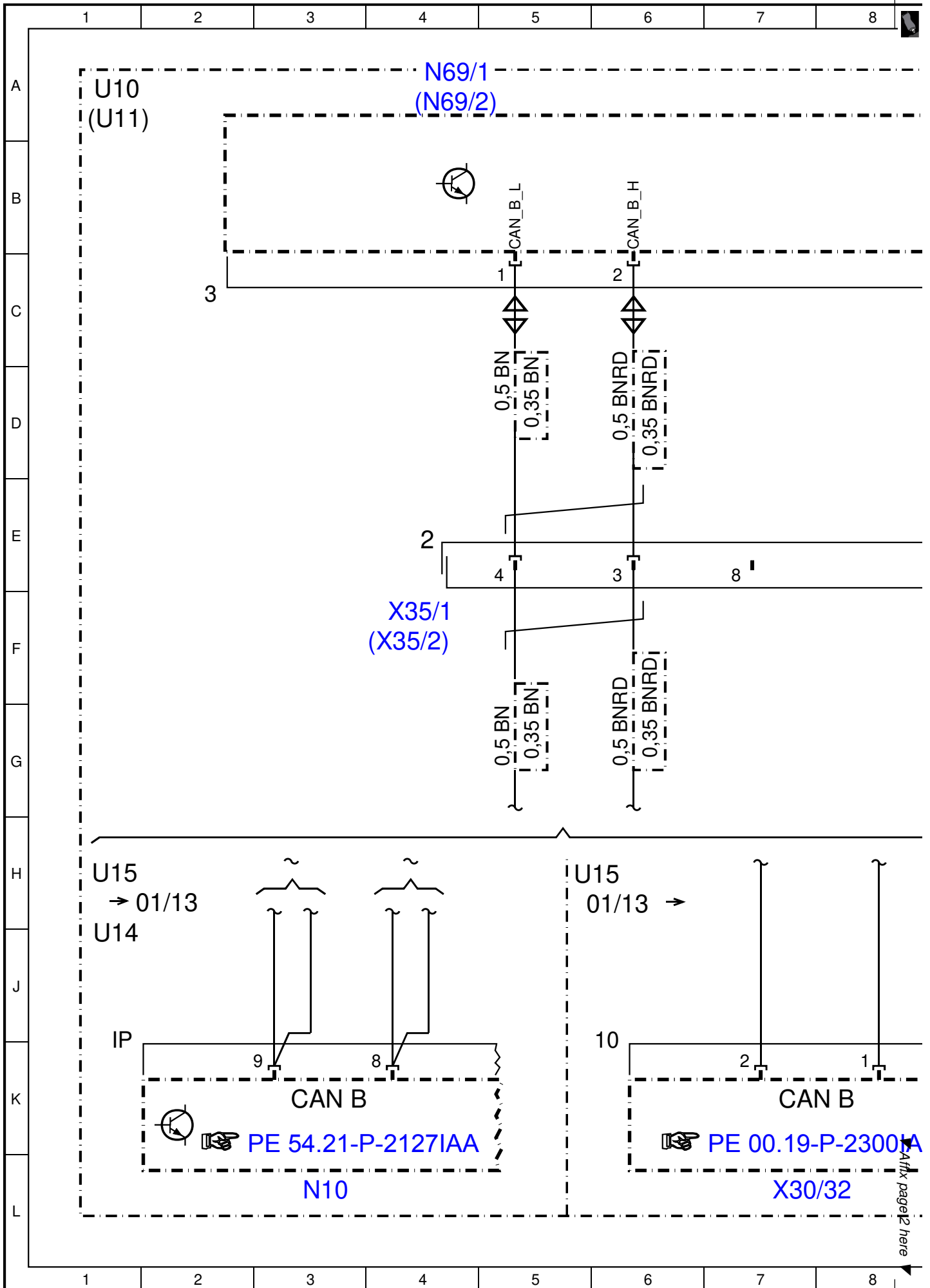

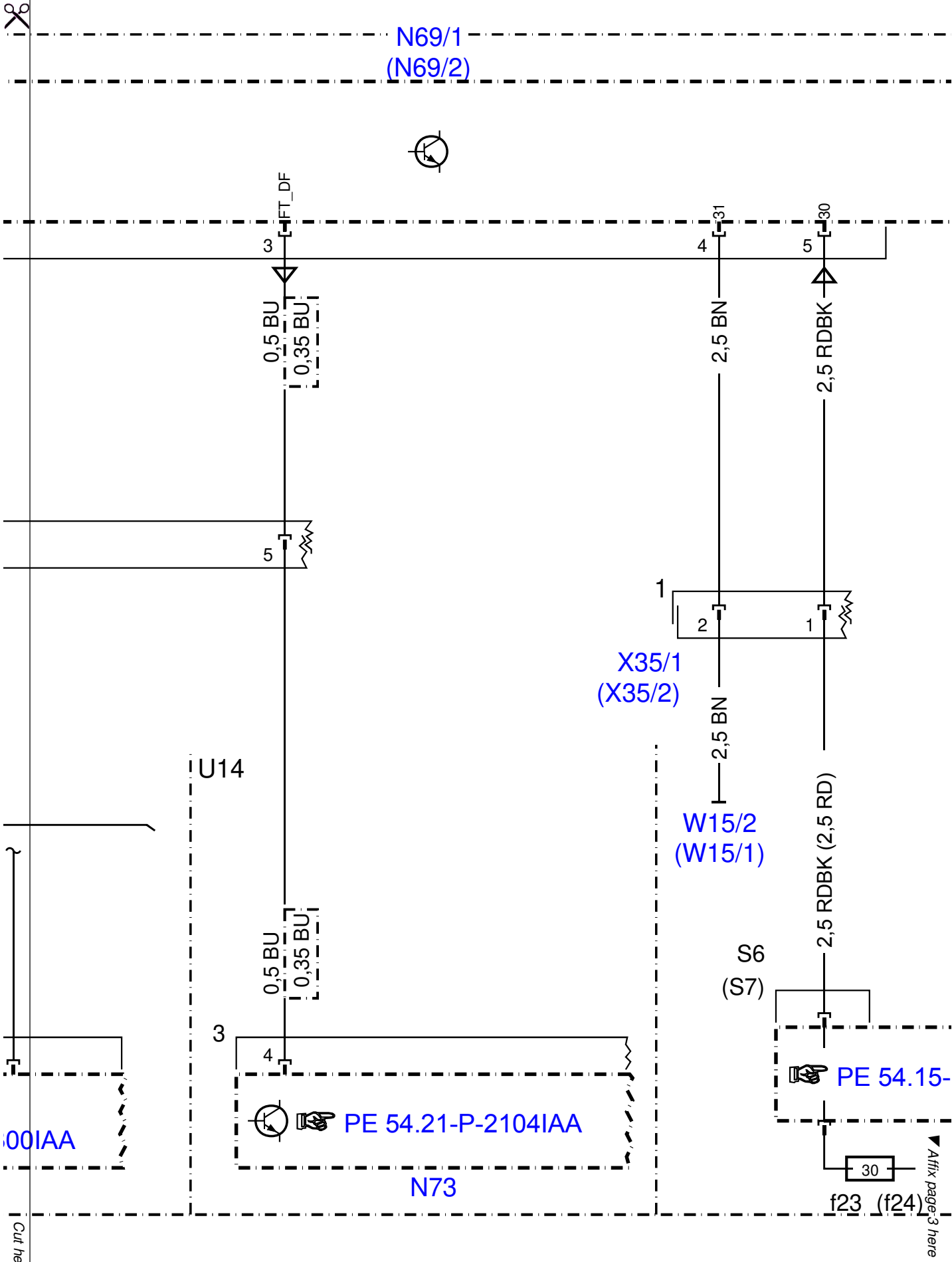

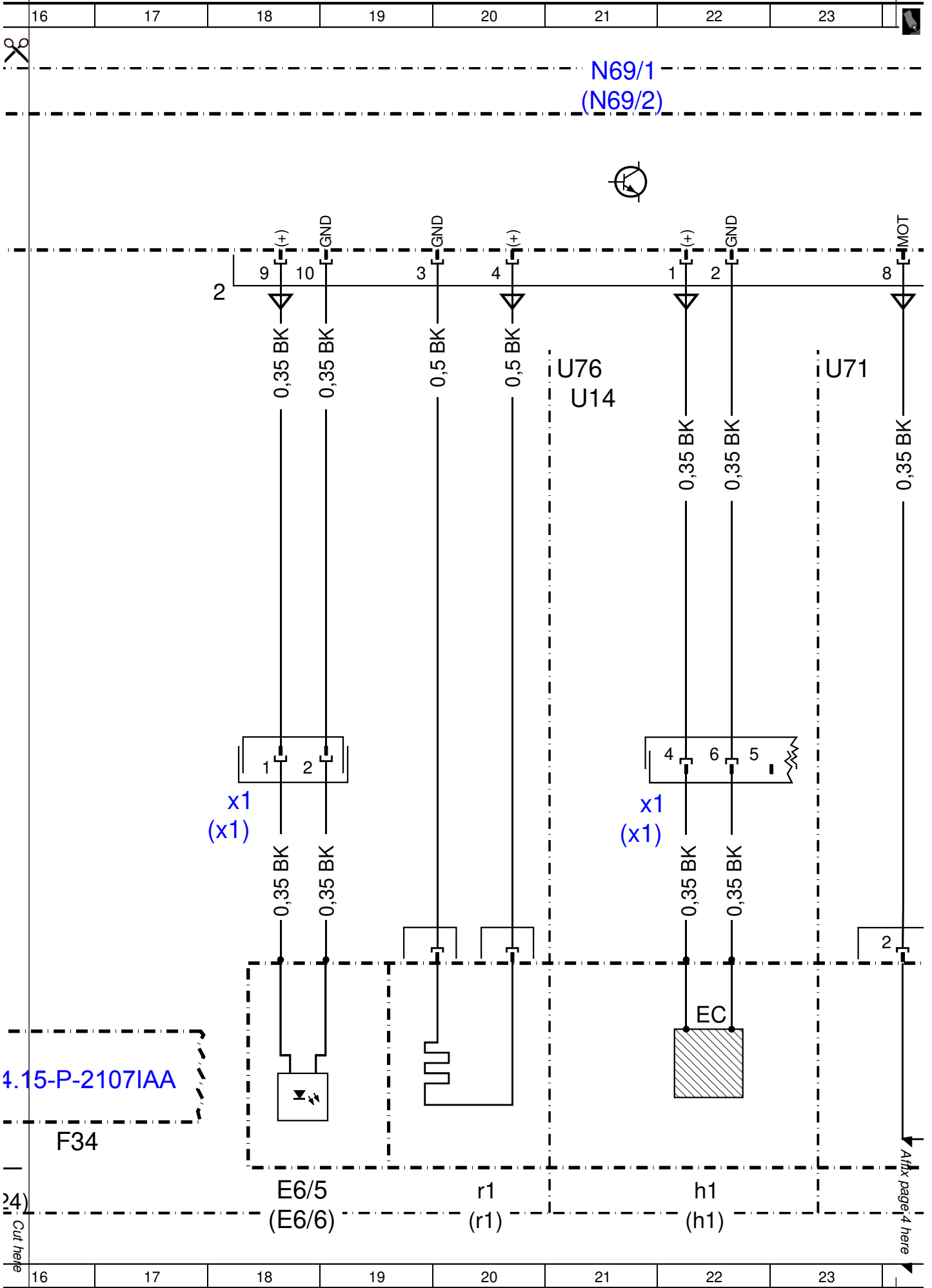



N69/1
(N69/2)

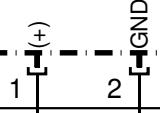

Code U62
U394

7.3

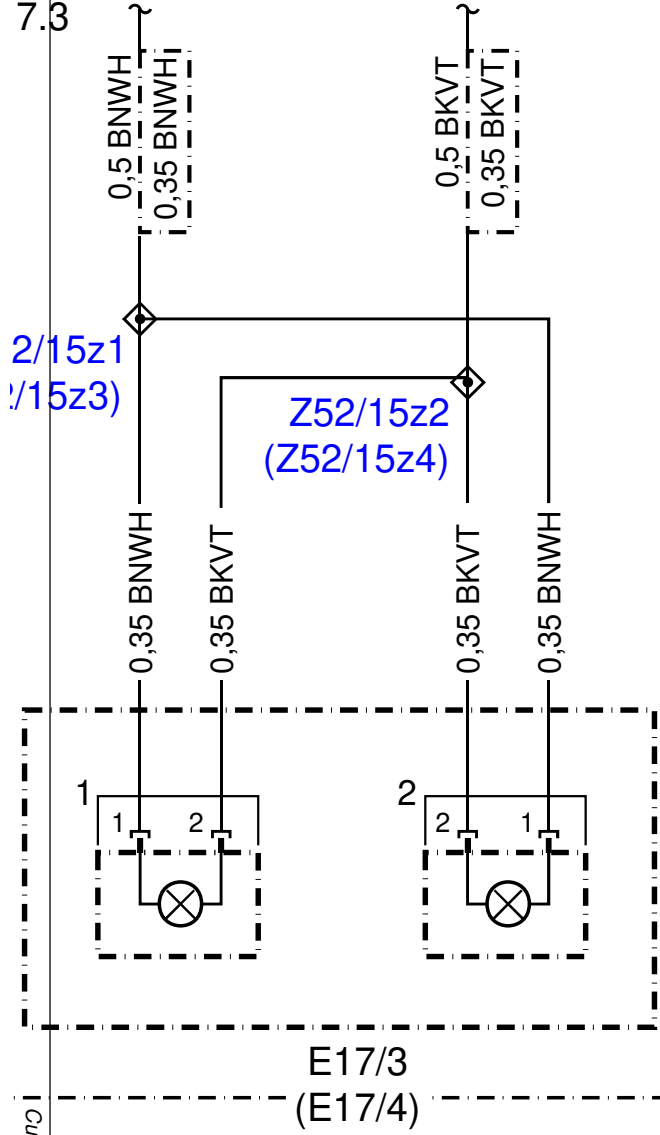

X157/7
(X157/6)

X157/7
(X157/6)

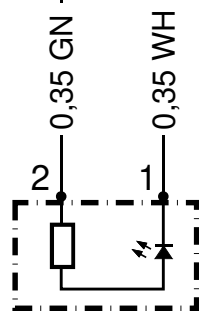

E17/11
(E17/12)

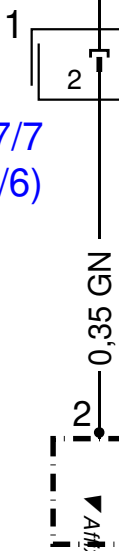

E17/11
(E17/12)

Cut here

Cut here

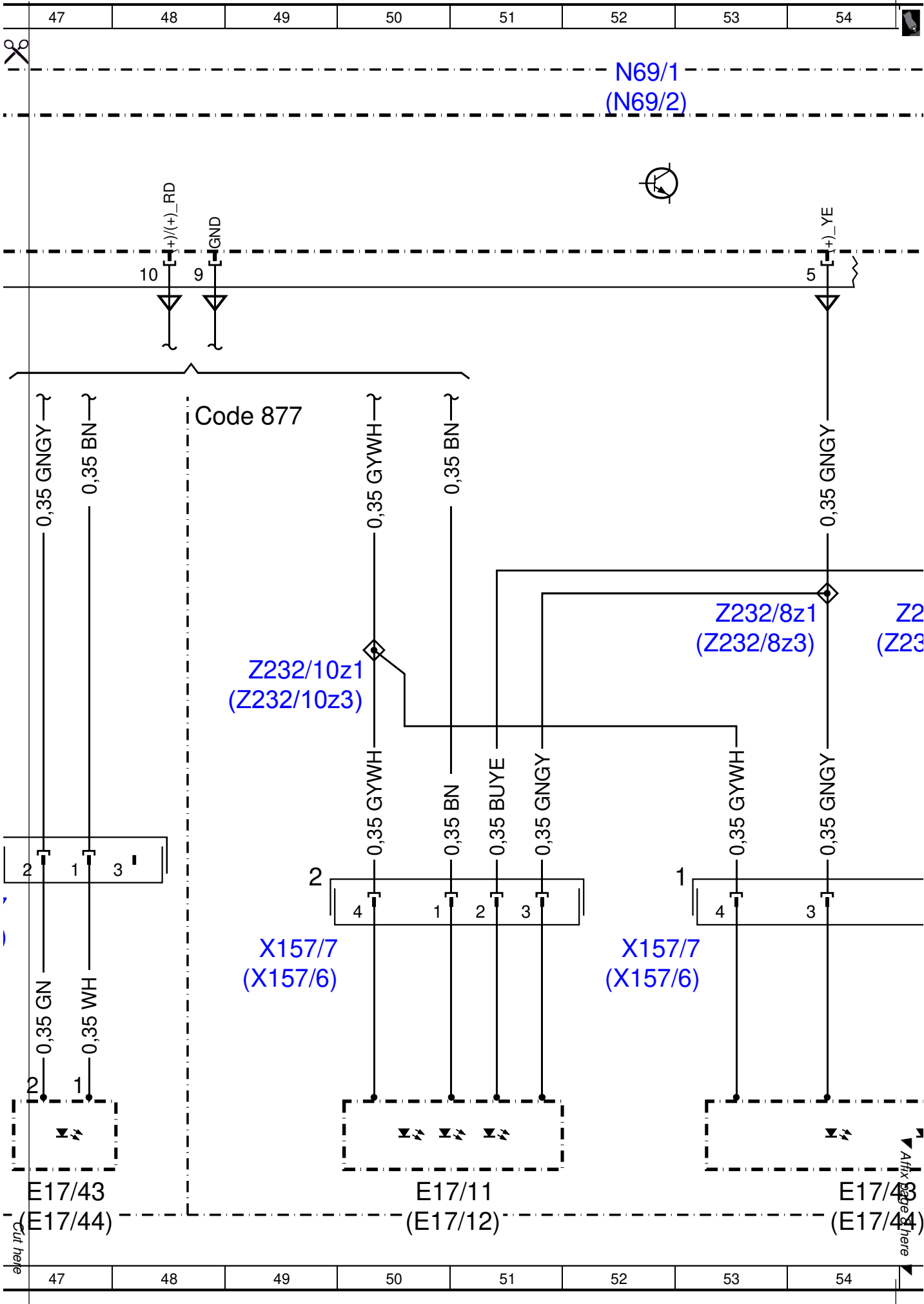



N69/1
(N69/2)

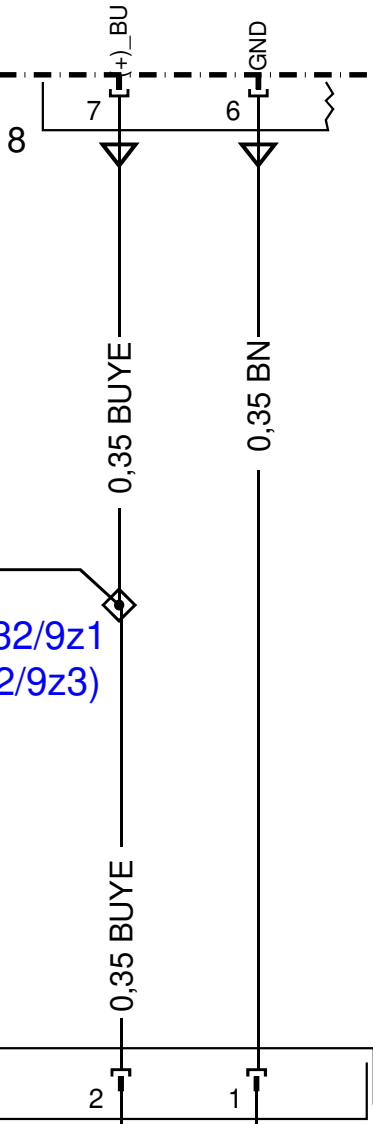

U71

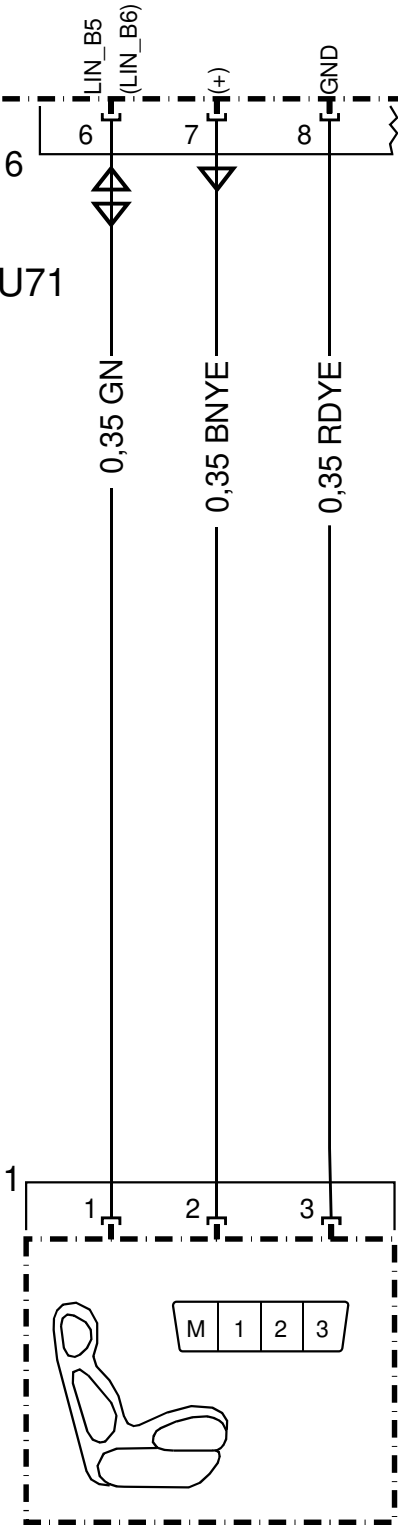

U14

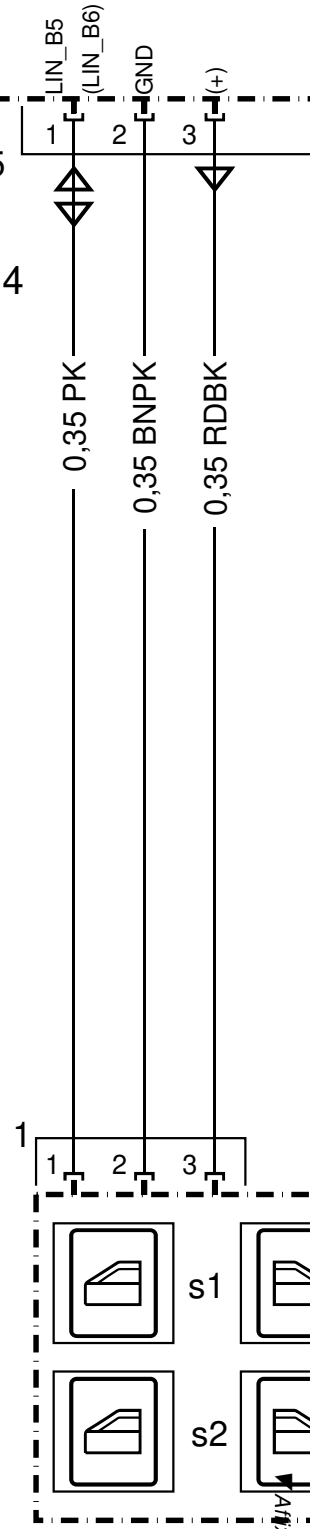

Z232/9z1
(Z232/9z3)

7/43

7/44

S22

(S23)

Fix page 9 here

Cut here



N69/1
(N69/2)

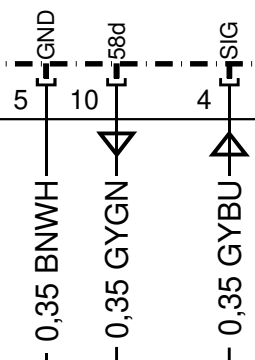

U15

U144

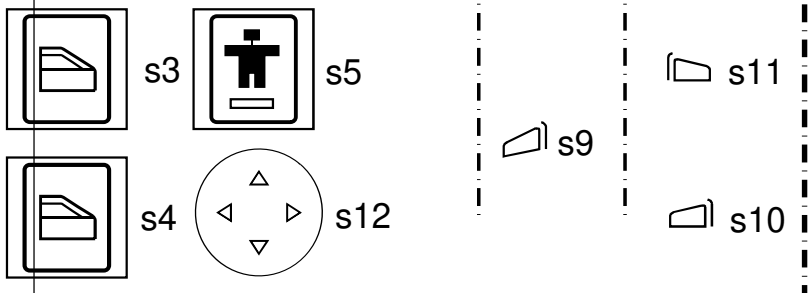

S20

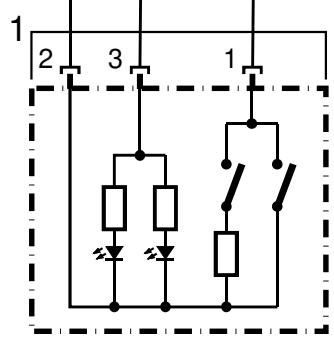

S85/5
(S85/6)

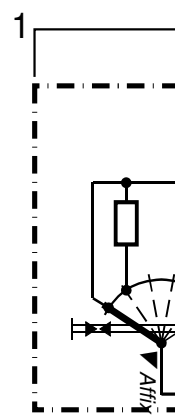

Align page 10 here

Cut here



N69/1
(N69/2)

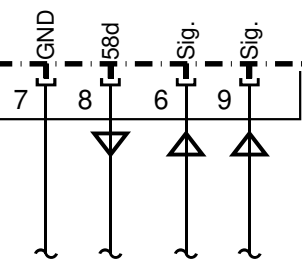

117.3
U14

Code 890
U14

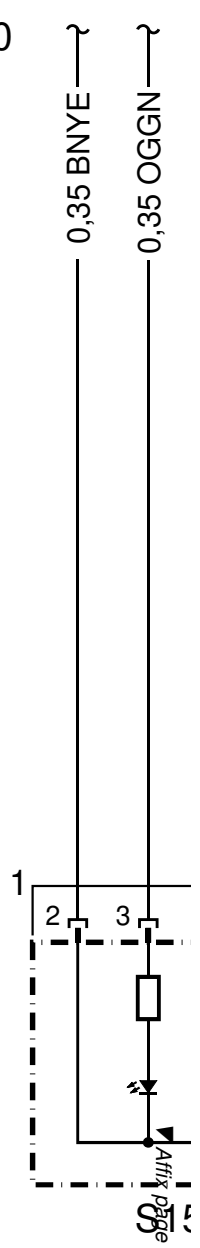
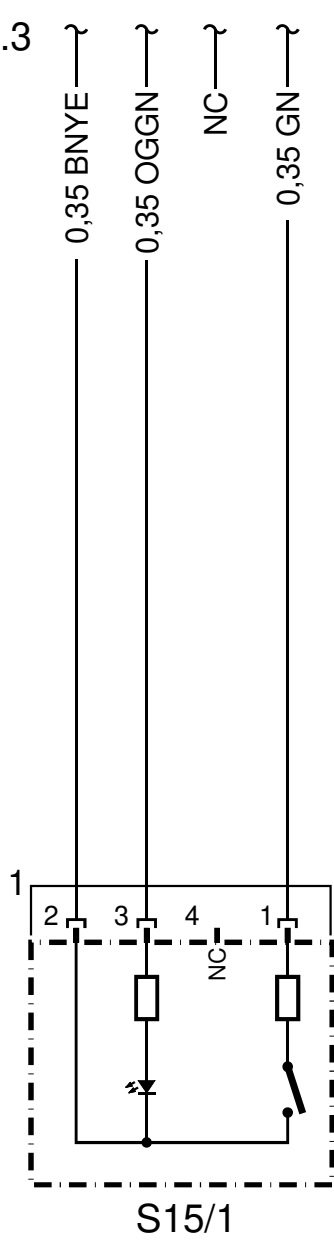
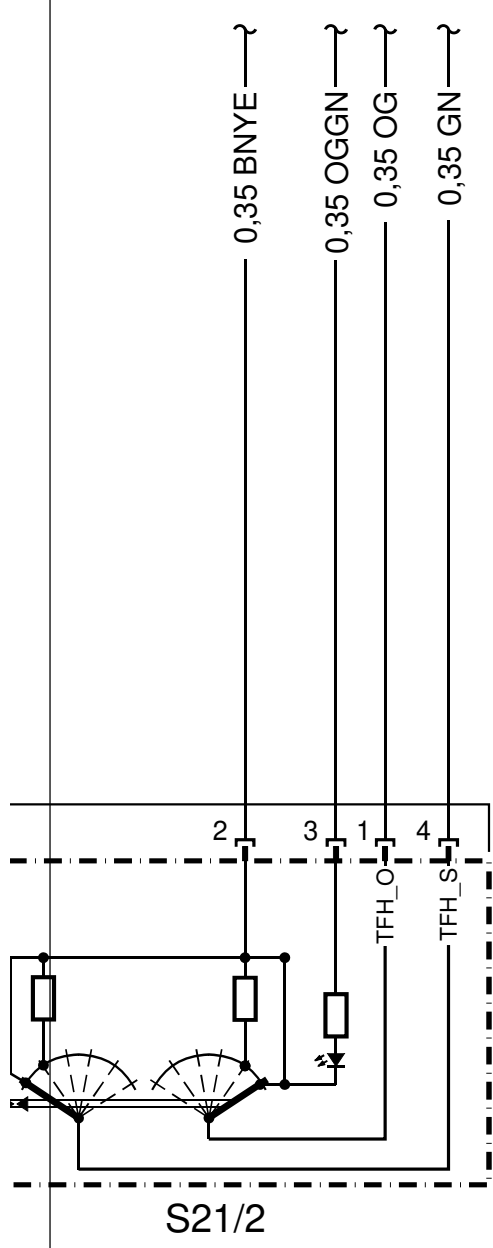

Cut here

Cut here



Code 880
U14

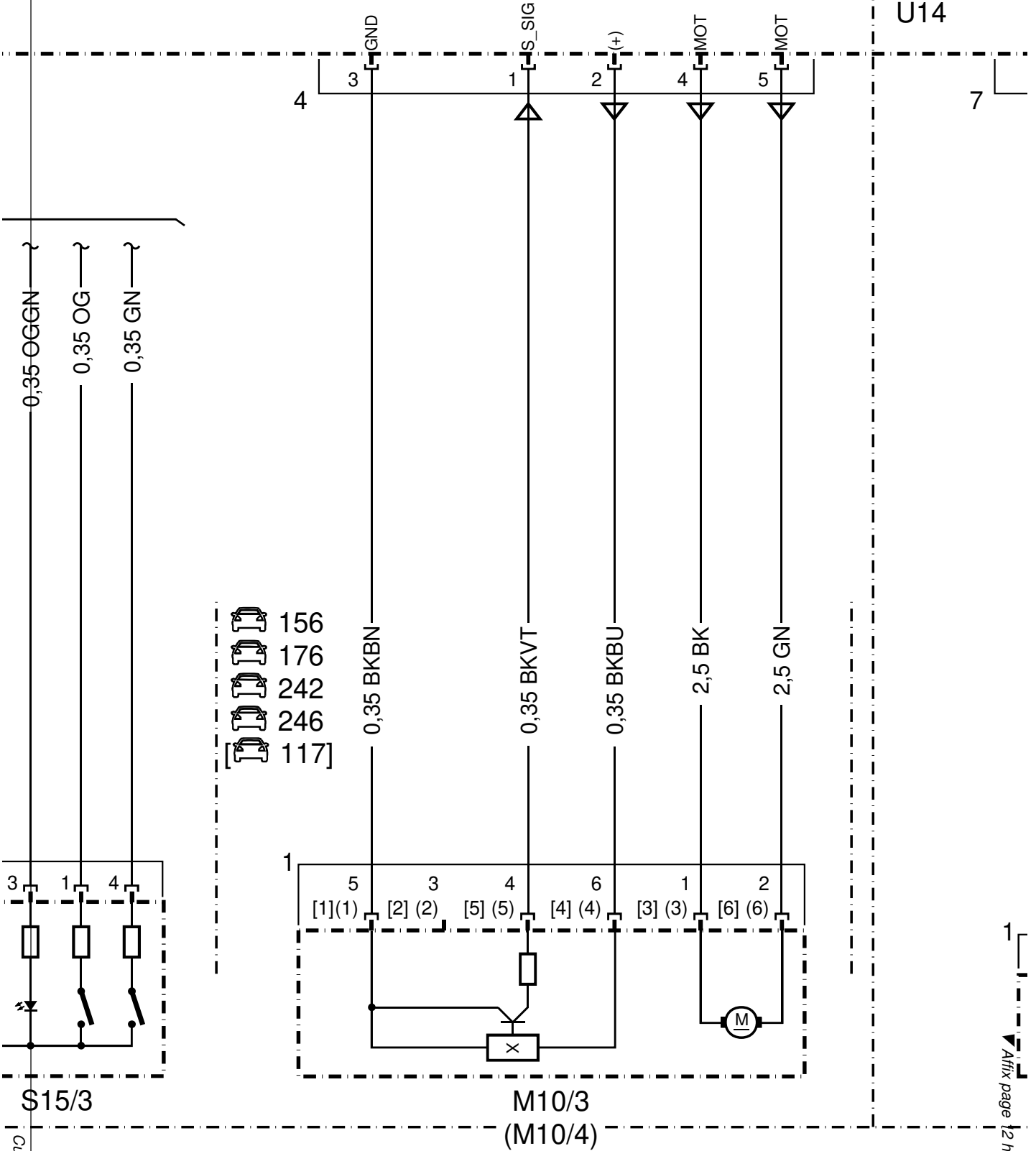

Cut here

Affix page 12 here

N69/1 (N69/2) N69/1 (N69/2)

80 U933 Code 885

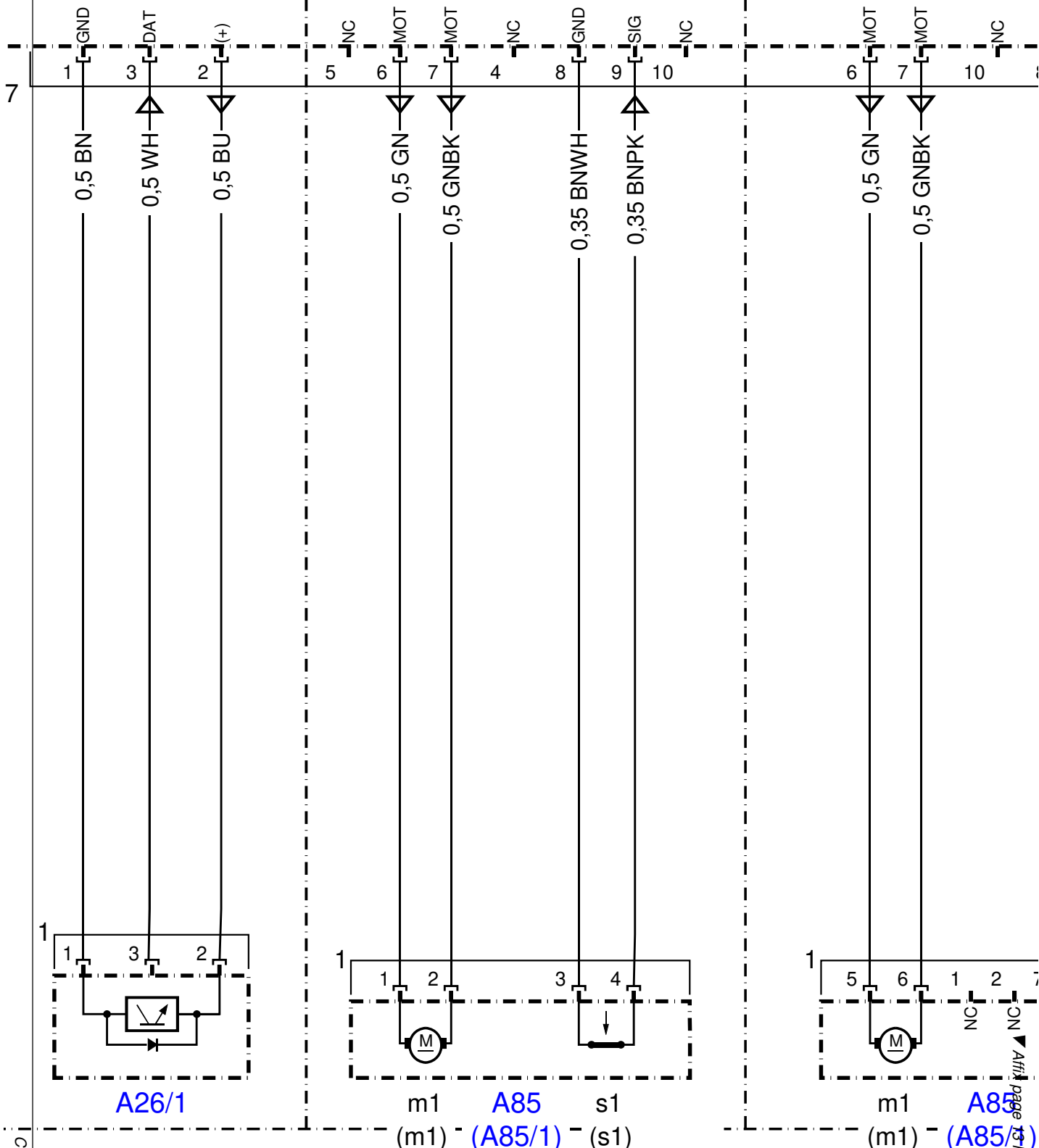

Cut here Cut here

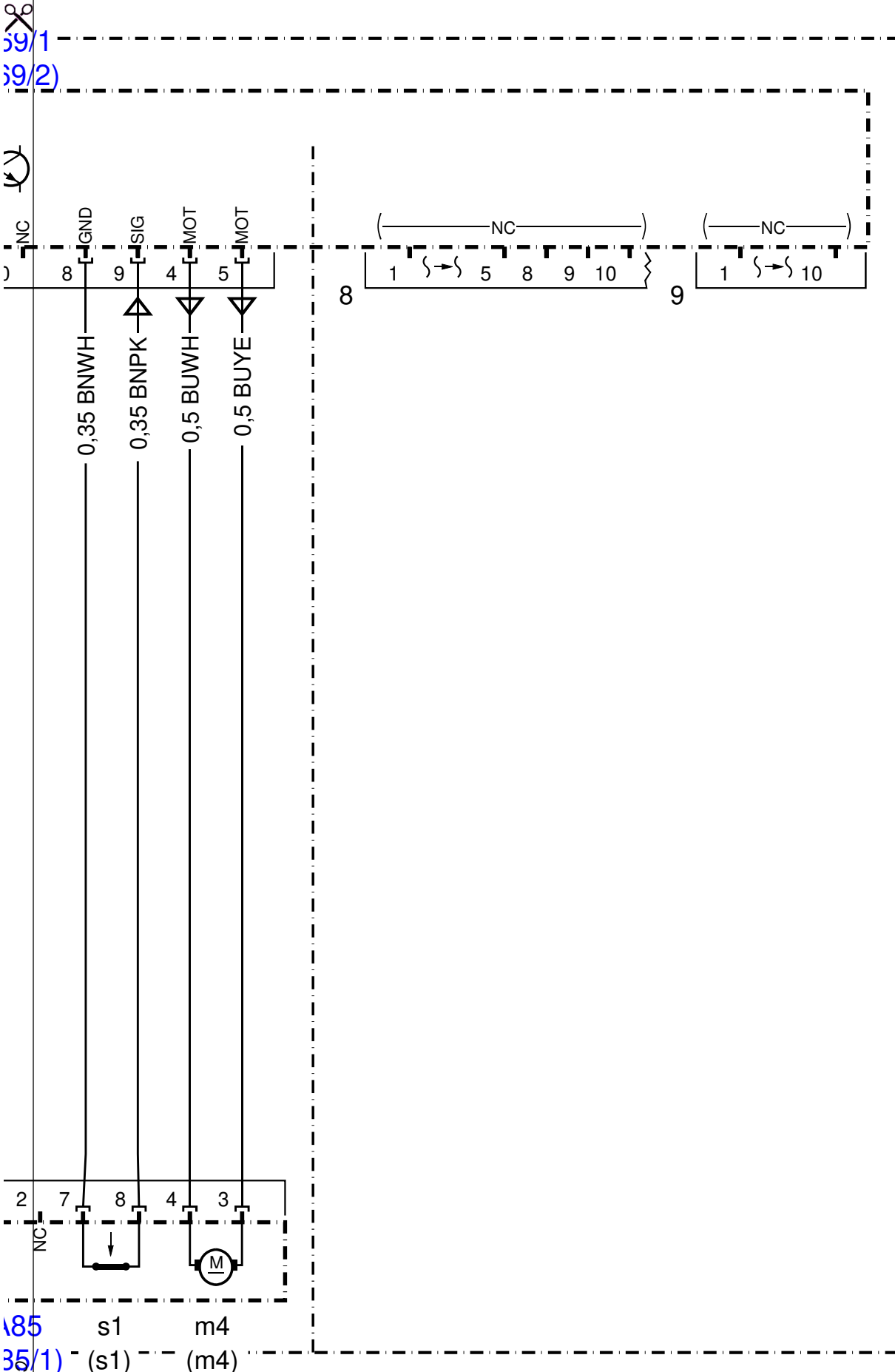

185
35/1) (s1) (m4)

▲ Affix page 14 here

