

- Parts list -

Vehicle	WDD2122021A564167 (D21)	E 220 CDI BlueEFFICIENCY Wagon
Color	197 - undefined	Equipment 208 -
Assortment class	PC	Group 35 Rear axle
Sub-group	075 Rear axle suspension	

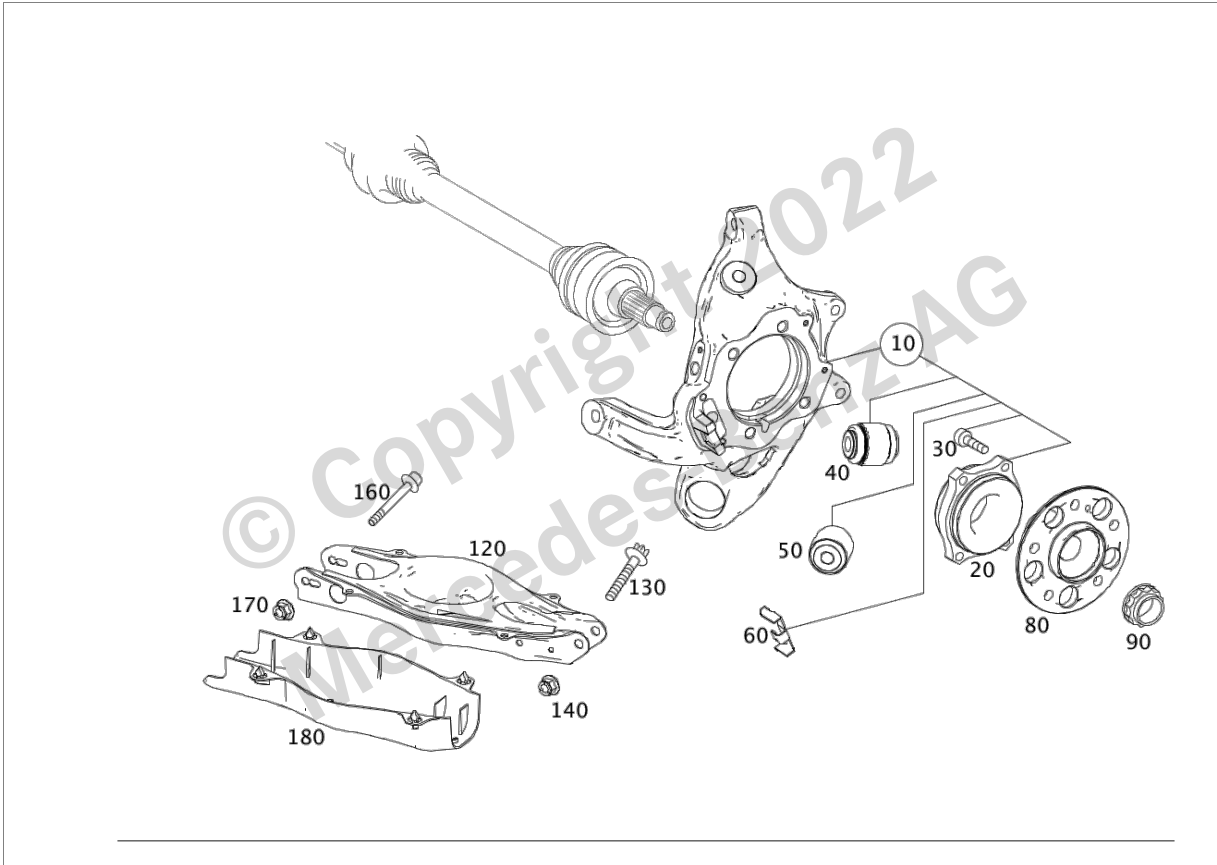





























Image ID: drawing_B35075000118

Item	Part number	Designation/additional information	Qty
10	A 212 350 21 08 	WHEEL CARRIER LEFT Replaced by: A 212 350 01 41	1
10	A 212 350 01 41 	WHEEL CARRIER LEFT Replaces: A 212 350 21 08	1
10	A 212 350 22 08 	WHEEL CARRIER RIGHT Replaced by: A 212 350 02 41	1
10	A 212 350 02 41 	WHEEL CARRIER RIGHT Replaces: A 212 350 22 08	1
20	A 211 981 02 27 	* WHEEL BEARING Left [001176] OBSERVE WIS	1
20	A 211 981 02 27 	* WHEEL BEARING Right [001176] OBSERVE WIS	1









Parts Information

Item	Part number	Designation/additional information	Qty
30	A 001 990 42 03 	* SCREW, ROUND HEXAL. HEAD Wheel bearing to left wheel carrier	4
30	A 001 990 42 03 	* SCREW, ROUND HEXAL. HEAD Wheel bearing to right wheel carrier	4
40	A 204 352 00 27 	* BALL JOINT Spring link to left wheel carrier	1
40	A 204 352 00 27 	* BALL JOINT Spring link to right wheel carrier	1
50	A 230 352 15 65  	* RUBBER BUSHING Thrust arm to left wheel carrier Replaced by: A 205 352 05 08	1
50	A 205 352 05 08  	* CONTROL ARM BUSHING Thrust arm to left wheel carrier Replaces: A 230 352 15 65	1
50	A 230 352 15 65  	* RUBBER BUSHING Thrust arm to right wheel carrier Replaced by: A 205 352 05 08	1
50	A 205 352 05 08  	* CONTROL ARM BUSHING Thrust arm to right wheel carrier Replaces: A 230 352 15 65	1
60	A 230 357 03 89 	* PLUG To left wheel carrier	1
60	A 230 357 03 89 	* PLUG To right wheel carrier	1
80	A 211 357 05 08	FLANGE Left	1
80	A 211 357 05 08	FLANGE Right	1
90	A 140 357 05 72	BIHEXAGONAL NUT W. COLLAR Rear axle shaft to hub, left  [414] THE OLD PART MUST NO LONGER BE INSTALLED Replaced by: A 000 353 13 73	2
90	A 000 353 13 73	COLLAR NUT FOR RA SHAFT Rear axle shaft to hub, right Replaces: A 140 357 05 72	2
120	A 212 350 04 06	SPRING LINK Spring link to left wheel carrier	1
120	A 212 350 04 06	SPRING LINK Spring link to right wheel carrier	1
130	A 002 990 75 03	SCREW, ROUND HEXAL. HEAD Spring link to left wheel carrier; M14X1,5X81,5	1
130	A 002 990 75 03	SCREW, ROUND HEXAL. HEAD Spring link to right wheel carrier; M14X1,5X81,5	1
140	A 001 990 77 52	NUT, SPECIAL FORM Spring link to left wheel carrier; M14X1,5  [414] THE OLD PART MUST NO LONGER BE INSTALLED Replaced by: N 000000 008268	1
140	N 000000 008268	NUT Spring link to left wheel carrier; M14X1,5 Replaces: A 001 990 77 52	1
140	A 001 990 77 52	NUT, SPECIAL FORM Spring link to right wheel carrier; M14X1,5  [414] THE OLD PART MUST NO LONGER BE INSTALLED Replaced by: N 000000 008268	1







Parts Information

Item	Part number	Designation/additional information	Qty
140	N 000000 008268	NUT Spring link to right wheel carrier; M14X1,5 Replaces: A 001 990 77 52	1
160	A 003 990 26 05	FLUTED SOCKET SCREW Spring link to left rear axle carrier; M12X1,5X110	1
160	A 003 990 26 05	FLUTED SOCKET SCREW Spring link to right rear axle carrier; M12X1,5X110	1
170	N 000000 003276	NUT Spring link to left rear axle carrier; M12X1.5  [414] THE OLD PART MUST NO LONGER BE INSTALLED Replaced by: A 001 990 78 52 Replaced by: N 000000 008269	1
170	A 001 990 78 52	NUT, SPECIAL FORM Spring link to left rear axle carrier; M12X1,5  [414] THE OLD PART MUST NO LONGER BE INSTALLED Replaced by: N 000000 008269 Replaces: N 000000 003276	1
170	N 000000 008269	NUT Spring link to left rear axle carrier; M12X1,5 Replaces: A 001 990 78 52 Replaces: N 000000 003276	1
170	N 000000 003276	NUT Spring link to right rear axle carrier; M12X1.5  [414] THE OLD PART MUST NO LONGER BE INSTALLED Replaced by: A 001 990 78 52 Replaced by: N 000000 008269	1
170	A 001 990 78 52	NUT, SPECIAL FORM Spring link to right rear axle carrier; M12X1,5  [414] THE OLD PART MUST NO LONGER BE INSTALLED Replaced by: N 000000 008269 Replaces: N 000000 003276	1
170	N 000000 008269	NUT Spring link to right rear axle carrier; M12X1,5 Replaces: A 001 990 78 52 Replaces: N 000000 003276	1
180	A 212 352 08 88	COVER LEFT SPRING CONTROL ARM	1
180	A 212 352 09 88	COVER RIGHT SPRING CONTROL ARM	1
250	A 204 350 15 06 	CAMBER ARM LEFT  Code: -(M156+M63/M157+M55); Replaced by: A 205 350 61 03	1
250	A 205 350 61 03 	CAMBER ARM LEFT  Code: -(M156+M63/M157+M55); Replaces: A 204 350 15 06	1
250	A 204 350 16 06 	CAMBER ARM RIGHT  Code: -(M156+M63/M157+M55); Replaced by: A 205 350 62 03	1













Parts Information

Item	Part number	Designation/additional information	Qty
250	A 205 350 62 03 	CAMBER ARM RIGHT  Code: -(M156+M63/M157+M55); Replaces: A 204 350 16 06	1
260	A 003 990 25 05	FLUTED SOCKET SCREW Camber strut to left wheel carrier; M12X1,5X94	1
260	A 003 990 25 05	FLUTED SOCKET SCREW Camber strut to right wheel carrier; M12X1,5X94	1
270	A 000 994 68 10	RETAINING WASHER Camber strut to left wheel carrier	1
270	A 000 994 68 10	RETAINING WASHER Camber strut to right wheel carrier	1
280	N 000000 003276	NUT Camber strut to left wheel carrier; M12X1,5  [414] THE OLD PART MUST NO LONGER BE INSTALLED Replaced by: A 001 990 78 52 Replaced by: N 000000 008269	1
280	A 001 990 78 52	NUT, SPECIAL FORM Camber strut to left wheel carrier; M12X1,5  [414] THE OLD PART MUST NO LONGER BE INSTALLED Replaced by: N 000000 008269 Replaces: N 000000 003276	1
280	N 000000 008269	NUT Camber strut to left wheel carrier; M12X1,5 Replaces: A 001 990 78 52 Replaces: N 000000 003276	1
280	N 000000 003276	NUT Camber strut to right wheel carrier; M12X1,5  [414] THE OLD PART MUST NO LONGER BE INSTALLED Replaced by: A 001 990 78 52 Replaced by: N 000000 008269	1
280	A 001 990 78 52	NUT, SPECIAL FORM Camber strut to right wheel carrier; M12X1,5  [414] THE OLD PART MUST NO LONGER BE INSTALLED Replaced by: N 000000 008269 Replaces: N 000000 003276	1
280	N 000000 008269	NUT Camber strut to right wheel carrier; M12X1,5 Replaces: A 001 990 78 52 Replaces: N 000000 003276	1
300	A 003 990 22 05	FLUTED SOCKET SCREW Camber strut to left rear axle carrier; M12X1,5X65	1
300	A 003 990 22 05	FLUTED SOCKET SCREW Camber strut to right rear axle carrier; M12X1,5X65	1
310	N 000000 003276	NUT Camber strut to left rear axle carrier; M12X1,5  [414] THE OLD PART MUST NO LONGER BE INSTALLED Replaced by: A 001 990 78 52 Replaced by: N 000000 008269	1
310	A 001 990 78 52	NUT, SPECIAL FORM Camber strut to left rear axle carrier; M12X1,5  [414] THE OLD PART MUST NO LONGER BE INSTALLED Replaced by: N 000000 008269 Replaces: N 000000 003276	1







Parts Information

Item	Part number	Designation/additional information	Qty
310	N 000000 008269	NUT Camber strut to left rear axle carrier; M12X1,5 Replaces: A 001 990 78 52 Replaces: N 000000 003276	1
310	N 000000 003276	NUT Camber strut to right rear axle carrier; M12X1.5  [414] THE OLD PART MUST NO LONGER BE INSTALLED Replaced by: A 001 990 78 52 Replaced by: N 000000 008269	1
310	A 001 990 78 52	NUT, SPECIAL FORM Camber strut to right rear axle carrier; M12X1,5  [414] THE OLD PART MUST NO LONGER BE INSTALLED Replaced by: N 000000 008269 Replaces: N 000000 003276	1
310	N 000000 008269	NUT Camber strut to right rear axle carrier; M12X1,5 Replaces: A 001 990 78 52 Replaces: N 000000 003276	1
350	A 204 350 21 06	TENSION STRUT LEFT  Code: -(M156+M63/M157+M55);	1
350	A 204 350 22 06	TENSION STRUT RIGHT  Code: -(M156+M63/M157+M55);	1
360	A 003 990 73 05	FLUTED SOCKET SCREW Strut rod to left wheel carrier; M12X102	1
360	A 003 990 73 05	FLUTED SOCKET SCREW Strut rod to right wheel carrier; M12X102	1
370	A 000 994 68 10	RETAINING WASHER Strut rod to left wheel carrier	1
370	A 000 994 68 10	RETAINING WASHER Strut rod to right wheel carrier	1
380	A 002 990 73 54	HEXAGON NUT WITH FLANGE Strut rod to left wheel carrier; M12X1,5	1
380	A 002 990 73 54	HEXAGON NUT WITH FLANGE Strut rod to right wheel carrier; M12X1,5	1
400	A 003 990 22 05	FLUTED SOCKET SCREW Strut rod to left rear axle carrier; M12X1,5X65	1
400	A 003 990 22 05	FLUTED SOCKET SCREW Strut rod to right rear axle carrier; M12X1,5X65	1
410	N 000000 003276	NUT Strut rod to left rear axle carrier; M12X1.5  [414] THE OLD PART MUST NO LONGER BE INSTALLED Replaced by: A 001 990 78 52 Replaced by: N 000000 008269	1
410	A 001 990 78 52	NUT, SPECIAL FORM Strut rod to left rear axle carrier; M12X1,5  [414] THE OLD PART MUST NO LONGER BE INSTALLED Replaced by: N 000000 008269 Replaces: N 000000 003276	1
410	N 000000 008269	NUT Strut rod to left rear axle carrier; M12X1,5 Replaces: A 001 990 78 52 Replaces: N 000000 003276	1



Parts Information

Item	Part number	Designation/additional information	Qty
410	N 000000 003276	NUT Strut rod to right rear axle carrier; M12X1.5  [414] THE OLD PART MUST NO LONGER BE INSTALLED Replaced by: A 001 990 78 52 Replaced by: N 000000 008269	1
410	A 001 990 78 52	NUT, SPECIAL FORM Strut rod to right rear axle carrier; M12X1,5  [414] THE OLD PART MUST NO LONGER BE INSTALLED Replaced by: N 000000 008269 Replaces: N 000000 003276	1
410	N 000000 008269	NUT Strut rod to right rear axle carrier; M12X1,5 Replaces: A 001 990 78 52 Replaces: N 000000 003276	1
450	A 204 350 05 53 	TIE ROD LEFT  Code: -(M156+M63/M157+M55); Replaced by: A 205 350 65 03	1
450	A 205 350 65 03 	TIE ROD LEFT  Code: -(M156+M63/M157+M55); Replaces: A 204 350 05 53	1
450	A 204 350 06 53 	TIE ROD RIGHT  Code: -(M156+M63/M157+M55); Replaced by: A 205 350 66 03	1
450	A 205 350 66 03 	TIE ROD RIGHT  Code: -(M156+M63/M157+M55); Replaces: A 204 350 06 53	1
460	A 003 990 24 05	FLUTED SOCKET SCREW Tie rod to left wheel carrier; M12X1,5X85  [414] THE OLD PART MUST NO LONGER BE INSTALLED Replaced by: A 004 990 66 05	1
460	A 004 990 66 05	FLUTED SOCKET SCREW Tie rod to left wheel carrier; M12X1,5X87 Replaces: A 003 990 24 05	1
460	A 003 990 24 05	FLUTED SOCKET SCREW Tie rod to right wheel carrier; M12X1,5X85  [414] THE OLD PART MUST NO LONGER BE INSTALLED Replaced by: A 004 990 66 05	1
460	A 004 990 66 05	FLUTED SOCKET SCREW Tie rod to right wheel carrier; M12X1,5X87 Replaces: A 003 990 24 05	1
470	A 000 994 68 10	RETAINING WASHER Tie rod to left wheel carrier	1
470	A 000 994 68 10	RETAINING WASHER Tie rod to right wheel carrier	1
480	N 000000 003276	NUT Tie rod to left wheel carrier; M12X1.5  [414] THE OLD PART MUST NO LONGER BE INSTALLED Replaced by: A 001 990 78 52 Replaced by: N 000000 008269	1





Parts Information

Item	Part number	Designation/additional information	Qty
480	A 001 990 78 52	NUT, SPECIAL FORM Tie rod to left wheel carrier; M12X1,5  [414] THE OLD PART MUST NO LONGER BE INSTALLED Replaced by: N 000000 008269 Replaces: N 000000 003276	1
480	N 000000 008269	NUT Tie rod to left wheel carrier; M12X1,5 Replaces: A 001 990 78 52 Replaces: N 000000 003276	1
480	N 000000 003276	NUT Tie rod to right wheel carrier; M12X1.5  [414] THE OLD PART MUST NO LONGER BE INSTALLED Replaced by: A 001 990 78 52 Replaced by: N 000000 008269	1
480	A 001 990 78 52	NUT, SPECIAL FORM Tie rod to right wheel carrier; M12X1,5  [414] THE OLD PART MUST NO LONGER BE INSTALLED Replaced by: N 000000 008269 Replaces: N 000000 003276	1
480	N 000000 008269	NUT Tie rod to right wheel carrier; M12X1,5 Replaces: A 001 990 78 52 Replaces: N 000000 003276	1
500	A 002 990 45 20	ECCENTRIC SCREW Tie rod to left rear axle carrier	1
500	A 002 990 45 20	ECCENTRIC SCREW Tie rod to right rear axle carrier	1
510	A 000 352 00 76	WINDOW Tie rod to left rear axle carrier	1
510	A 000 352 00 76	WINDOW Tie rod to right rear axle carrier	1
520	N 000000 003276	NUT Tie rod to left rear axle carrier; M12X1.5  [414] THE OLD PART MUST NO LONGER BE INSTALLED Replaced by: A 001 990 78 52 Replaced by: N 000000 008269	1
520	A 001 990 78 52	NUT, SPECIAL FORM Tie rod to left rear axle carrier; M12X1,5  [414] THE OLD PART MUST NO LONGER BE INSTALLED Replaced by: N 000000 008269 Replaces: N 000000 003276	1
520	N 000000 008269	NUT Tie rod to left rear axle carrier; M12X1,5 Replaces: A 001 990 78 52 Replaces: N 000000 003276	1
520	N 000000 003276	NUT Tie rod to right rear axle carrier; M12X1.5  [414] THE OLD PART MUST NO LONGER BE INSTALLED Replaced by: A 001 990 78 52 Replaced by: N 000000 008269	1

Parts Information

Item	Part number	Designation/additional information	Qty
520	A 001 990 78 52	NUT, SPECIAL FORM Tie rod to right rear axle carrier; M12X1,5  [414] THE OLD PART MUST NO LONGER BE INSTALLED Replaced by: N 000000 008269 Replaces: N 000000 003276	1
520	N 000000 008269	NUT Tie rod to right rear axle carrier; M12X1,5 Replaces: A 001 990 78 52 Replaces: N 000000 003276	1
540	A 204 350 27 06	THRUST ARM Left Replaced by: A 205 350 63 03	1
540	A 205 350 63 03	THRUST ARM Left Replaces: A 204 350 27 06	1
540	A 204 350 27 06	THRUST ARM Right Replaced by: A 205 350 63 03	1
540	A 205 350 63 03	THRUST ARM Right Replaces: A 204 350 27 06	1
550	A 003 990 72 05	FLUTED SOCKET SCREW Thrust arm to left wheel carrier; M12X72 Replaced by: A 004 990 00 03	1
550	A 004 990 00 03	SCREW, ROUND HEXAL. HEAD Thrust arm to left wheel carrier; M12X1,5X72 Replaces: A 003 990 72 05	1
550	A 003 990 72 05	FLUTED SOCKET SCREW Thrust arm to right wheel carrier; M12X72 Replaced by: A 004 990 00 03	1
550	A 004 990 00 03	SCREW, ROUND HEXAL. HEAD Thrust arm to right wheel carrier; M12X1,5X72 Replaces: A 003 990 72 05	1
560	A 002 990 73 54	HEXAGON NUT WITH FLANGE Thrust arm to left wheel carrier; M12X1,5	1
560	A 002 990 73 54	HEXAGON NUT WITH FLANGE Thrust arm to right wheel carrier; M12X1,5	1
580	A 003 990 22 05	FLUTED SOCKET SCREW Thrust arm to left rear axle carrier; M12X1,5X65	1
580	A 003 990 22 05	FLUTED SOCKET SCREW Thrust arm to right rear axle carrier; M12X1,5X65	1
590	N 000000 003276	NUT Thrust arm to left rear axle carrier; M12X1,5  [414] THE OLD PART MUST NO LONGER BE INSTALLED Replaced by: A 001 990 78 52 Replaced by: N 000000 008269	1
590	A 001 990 78 52	NUT, SPECIAL FORM Thrust arm to left rear axle carrier; M12X1,5  [414] THE OLD PART MUST NO LONGER BE INSTALLED Replaced by: N 000000 008269 Replaces: N 000000 003276	1
590	N 000000 008269	NUT Thrust arm to left rear axle carrier; M12X1,5 Replaces: A 001 990 78 52 Replaces: N 000000 003276	1

Parts Information

Item	Part number	Designation/additional information	Qty
590	N 000000 003276	NUT Thrust arm to right rear axle carrier; M12X1.5  [414] THE OLD PART MUST NO LONGER BE INSTALLED Replaced by: A 001 990 78 52 Replaced by: N 000000 008269	1
590	A 001 990 78 52	NUT, SPECIAL FORM Thrust arm to right rear axle carrier; M12X1,5  [414] THE OLD PART MUST NO LONGER BE INSTALLED Replaced by: N 000000 008269 Replaces: N 000000 003276	1
590	N 000000 008269	NUT Thrust arm to right rear axle carrier; M12X1,5 Replaces: A 001 990 78 52 Replaces: N 000000 003276	1
610	A 204 352 12 88	COVER Left  [414] THE OLD PART MUST NO LONGER BE INSTALLED Replaced by: A 218 352 00 00	1
610	A 218 352 00 00	TRIM Left Replaces: A 204 352 12 88	1
610	A 204 352 12 88	COVER Right  [414] THE OLD PART MUST NO LONGER BE INSTALLED Replaced by: A 218 352 00 00	1
610	A 218 352 00 00	TRIM Right Replaces: A 204 352 12 88	1
620	A 204 352 14 88	COVER THRUST ARM, TOP PART	2