

Document title Remove and install wiper arm

Document number ar8230p6100cw

Model 204, 207, 212, 218

Modification notes

17.04.2014	New picture inserted	Picture number P82.30-3209-08	
17.04.2014	Specialist note inserted	AS 4.2 factual information inserted	

Model 204.0/2, 207, 212.0/2, 218, shown on model 204.0

- 1 Driver-side wiper arm
- 2 Passenger-side wiper arm
- 3 Cap
- 4 Caps

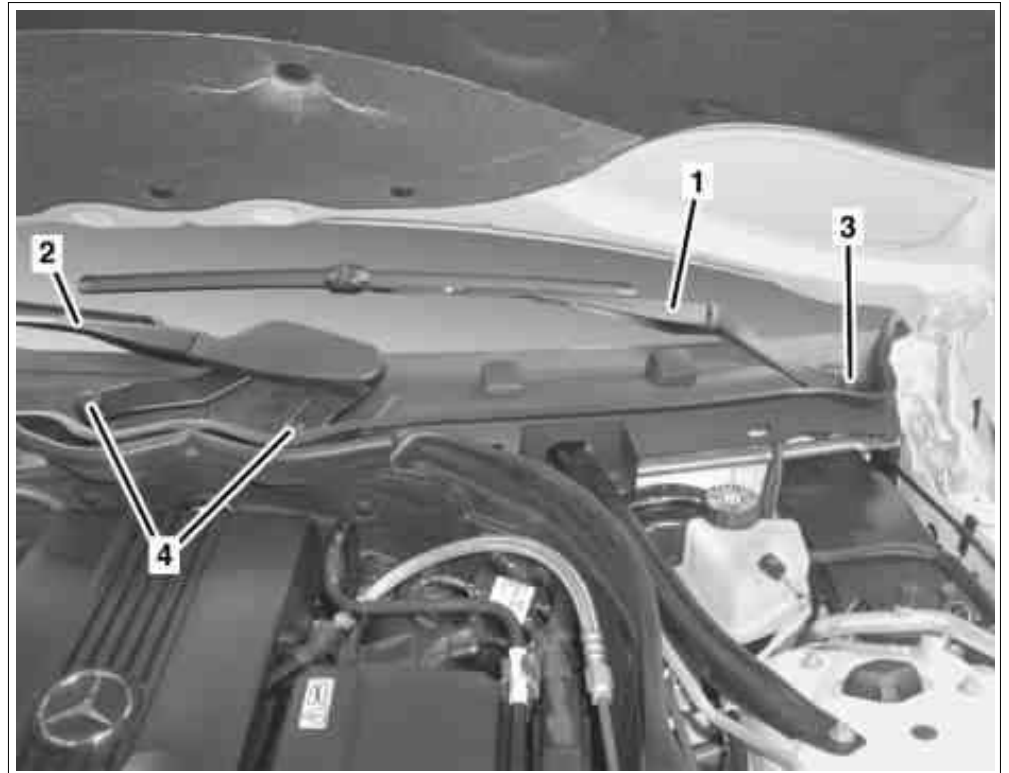

P82.30-2630-11

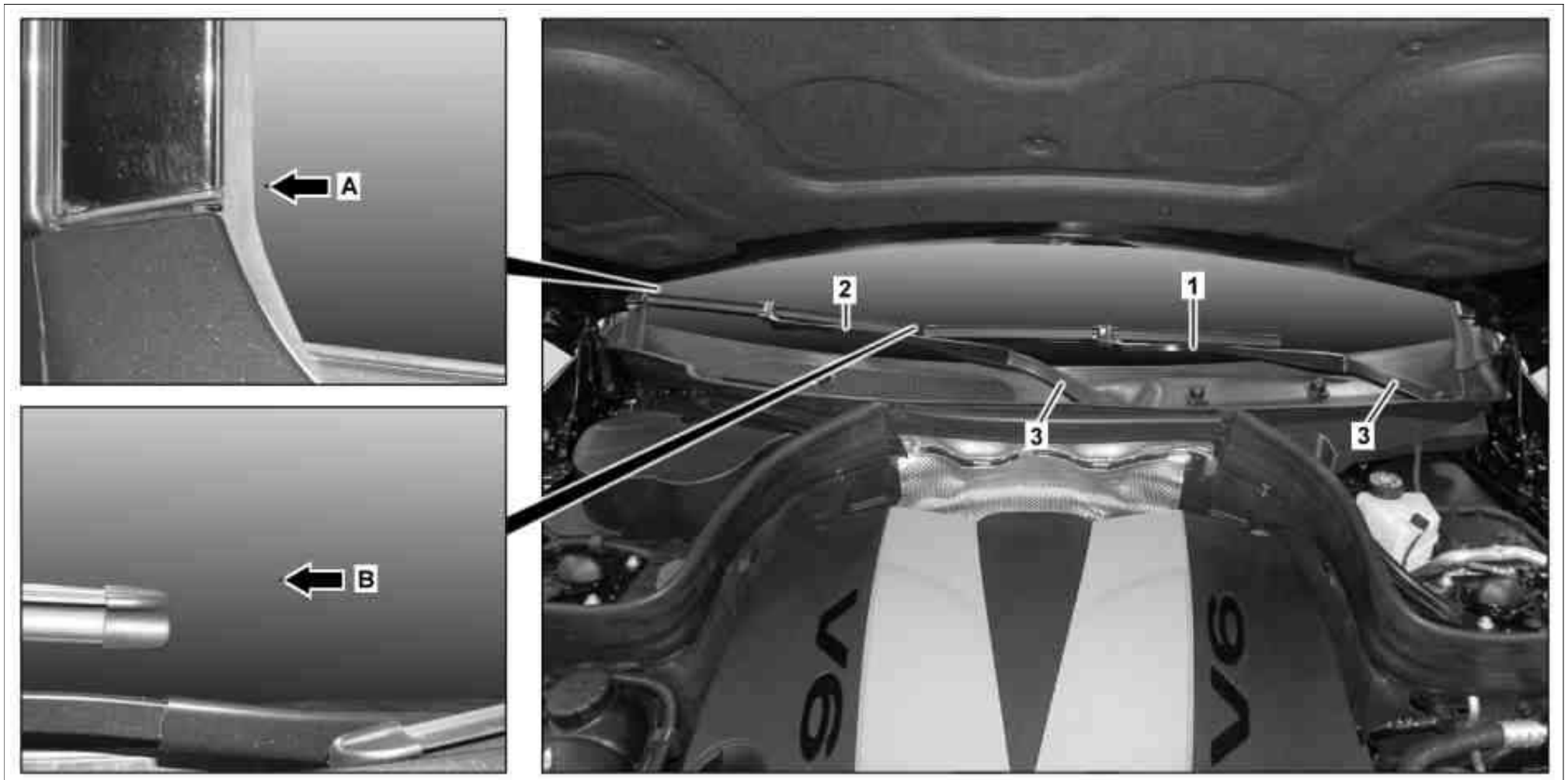

P82.30-2856-09

MODEL 204.9

- 1 Driver-side wiper arm
- 2 Passenger-side wiper arm
- 3 Cap

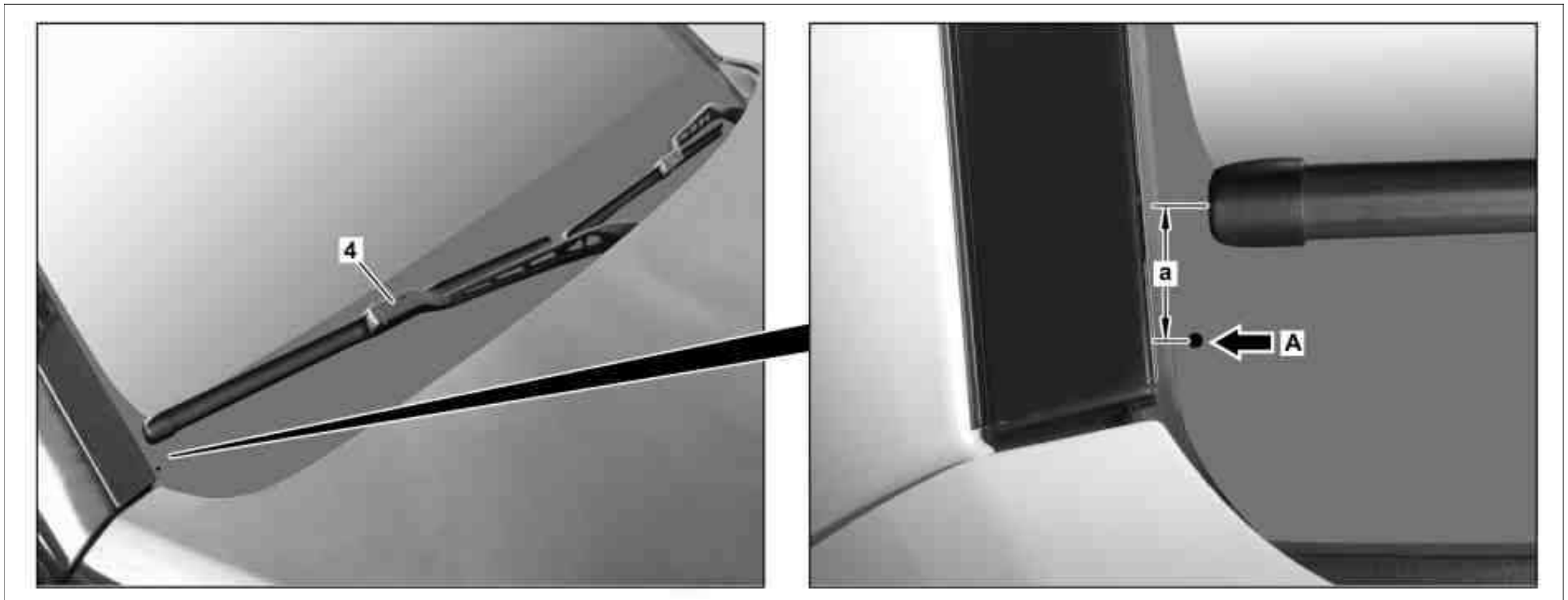

P82.30-3209-08

4 Passenger-side wiper arm

	Injury hazard from pinching and crushing, in extreme cases extremities can even be cut off when caught in windshield wiper mechanism.	When working on the windshield wiper mechanism, always switch off the ignition and store transmitter key outside of transmission range (at least 2 m).	AS82.30-Z-0001-01A
☒ ☒	Remove/install		
1	Bring wiper system into park position		
2.1	Switch off ignition and remove transmitter key from ignition lock	Model 204, 207, 212, 218 except code 889 (KEYLESS-GO)	
2.2	Switch off ignition, remove KEYLESS-GO start/stop button from electronic ignition lock control unit	Model 204, 207, 212, 218 with code 889 (KEYLESS-GO)	
5	Remove cap (3), unscrew nut and detach driver-side wiper arm (1)	<p>i Model 204, 207 Installation: Position tip of wiper blade on driver-side wiper arm (1) onto assembly marking (arrow B) in the windshield's silk-screen print.</p> <p>i Model 212, 218 Installation: Position tip of wiper blade on driver-side wiper arm (1) 60 mm above the water collector.</p> <p>Nm Nut to wiper arm ☞ Puller ☞ Thrust washer M 10x1.5</p>	<p>*BA82.30-P-1001-01M *201589143300 *210589046300</p>
6.1	Detach caps (4), unscrew nuts and remove passenger-side wiper arm (2)	<p>Model 204.0/2, 207, 212, 218</p> <p>i Installation: Position front passenger side wiper blade (2) onto assembly marking in windshield's silk-screen print.</p> <p>Nm Nut to wiper arm ☞ Puller ☞ Thrust washer M 10x1.5</p>	<p>*BA82.30-P-1001-01M *201589143300 *210589046300</p>
6.2	Remove cap (3), unscrew nut and remove passenger-side wiper arm (2)	<p>Model 204.9</p> <p>i Model 204.9 up to 1/31/14 Installation: Position front passenger side wiper blade (2) onto assembly marking (arrow A) in windshield's silk-screen print.</p> <p>i Model 204.9 as of 2/1/14 Installation: Position front passenger side wiper blade (4) approx. 21 mm (space a) over the assembly marking (arrow A) in the windshield's silk-screen print.</p> <p>Nm Nut to wiper arm ☞ Puller ☞ Thrust washer M 10x1.5</p>	<p>*BA82.30-P-1001-01M *201589143300 *210589046300</p>
7	Install in the reverse order		

Nm Windshield wiper

Number	Designation		Model 204	Model 207
BA82.30-P-1001-01M	Nut to wiper arm	Nm	30	30

Nm Windshield wiper

Number	Designation		Model 212	Model 218
BA82.30-P-1001-01M	Nut to wiper arm	Nm	30	30

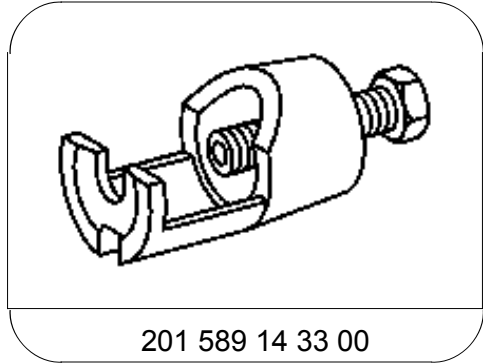

Puller

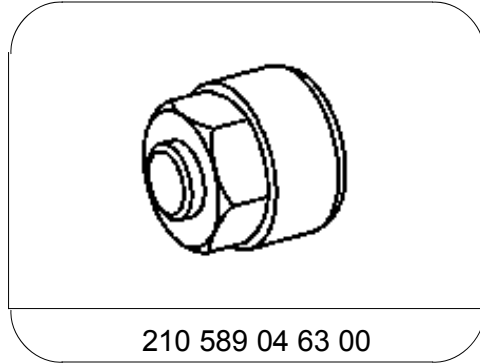

Thrust washer M 10x1.5