

- Parts list -

Vehicle	WDDHF8HB6BA398968 (D02)	E 350 4MATIC Sedan	
Color	359 - TANSANITBLAU - METALLICLACK	Equipment	105 - KUNSTLEDER - BEIGE
FIN: WDD2120871A398968		Assortment class	PC
Group	42 Brake system	Sub-group	030 Front wheel brake

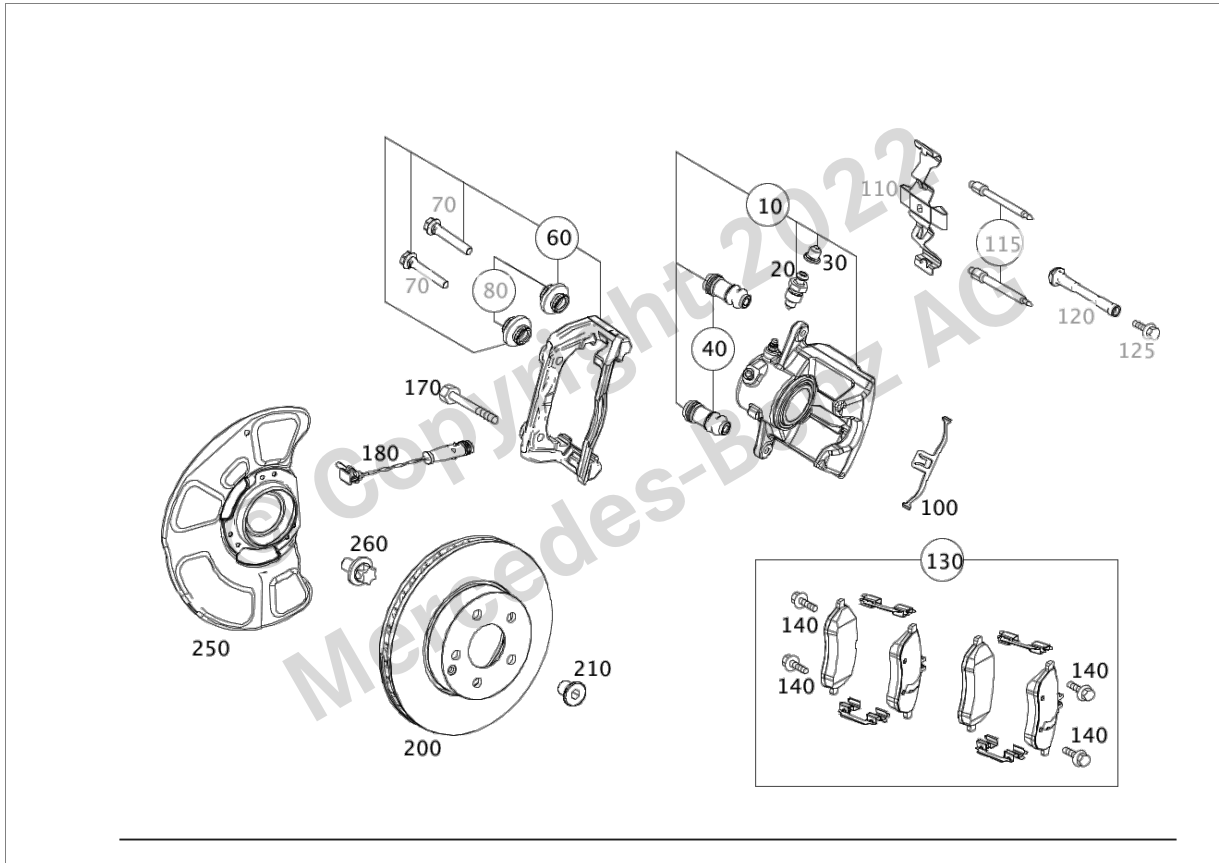























Image ID: drawing_B42030000136

Item	Part number	Designation/additional information	Qty
10	A 204 421 37 81	BRAKE CALIPER LEFT PARTS KIT WITH GUIDE SLEEVE Code: M272+M35+M005+494;	1
10	A 204 421 38 81	BRAKE CALIPER RIGHT PARTS KIT WITH GUIDE SLEEVE Code: M272+M35+M005+494;	1
20	A 000 421 43 65	* BLEED VALVE Code: M272+M35+M005+494;	2
30	A 000 421 10 48	* CAP BLEEDER VALVE Code: M272+M35+M005+494;	2
40	A 001 421 25 86	* PARTS KIT, BELLOWS PARTS KIT WITH GUIDE SLEEVE Code: M272+M35+M005+494;	2

Parts Information

Item	Part number	Designation/additional information	Qty
60	A 204 421 11 94	BRAKE CARRIER WITHOUT GUIDE SLEEVE  [001692] ATTN.: REPLACE FASTENERS/NOTE WORKSHOP LITERATURE  Code: M272+M35+M005+494;	2
100	A 000 993 46 07	RETAINING SPRING  Code: M272+M35+M005+494;	2
130	A 005 420 13 20	PARTS KIT, BRAKEPAD PARTS KIT  [431] WHEN SELLING BRAKE LININGS TO END USERS/DESK BUYERS THE A 203 005 25 99 IS TO BE HANDED OVER FREE OF CHARGE  Code: M272+M35+M005+494; Replaced by: A 007 420 58 20	1
130	A 007 420 58 20 	PARTS KIT, BRAKEPAD PARTS KIT  [431] WHEN SELLING BRAKE LININGS TO END USERS/DESK BUYERS THE A 203 005 25 99 IS TO BE HANDED OVER FREE OF CHARGE  Code: M272+M35+M005+494; Replaces: A 005 420 13 20	1
130	A 007 420 58 20 	PARTS KIT, BRAKEPAD Parts kit  [431] WHEN SELLING BRAKE LININGS TO END USERS/DESK BUYERS THE A 203 005 25 99 IS TO BE HANDED OVER FREE OF CHARGE  Code: M272+M35+M005+494;	1
140	A 001 990 59 00	HEXAGON HEAD BOLT CALIPER TO BRAKE ANCHOR  Code: M272+M35+M005+494;	4
170	A 124 421 04 71	HEXAGON HEAD BOLT CALIPER TO STEERING KNUCKLE; M12X1.5 X 45  Code: -(M156+M63/M157+M55);	4
180	A 211 540 17 17	BRAKEPAD WEAR SENSOR BRAKE LINING WEAR INDICATOR  Code: -(M156+M63/M157+M55);	1
200	A 204 421 08 12	BRAKE DISK Front left  [408] ONLY REPLACEABLE BY PAIRS  Code: M272+M35; Replaced by: A 000 421 12 12	1
200	A 204 421 08 12	BRAKE DISK Front right  [408] ONLY REPLACEABLE BY PAIRS  Code: M272+M35; Replaced by: A 000 421 12 12	1
200	A 000 421 12 12	BRAKE DISK, VENTED Front left  [408] ONLY REPLACEABLE BY PAIRS  Code: M272+M35; Replaces: A 204 421 08 12	1
200	A 000 421 12 12	BRAKE DISK, VENTED Front right  [408] ONLY REPLACEABLE BY PAIRS  Code: M272+M35; Replaces: A 204 421 08 12	1

Parts Information

Item	Part number	Designation/additional information	Qty
210	A 220 421 01 71	FIT SCREW BRAKE DISC TO WHEEL HUB; M8X12	2
250	A 204 421 11 20	PROTECTIVE METAL SHEET LEFT ☐ Code: M005+-M157;	1
250	A 204 421 12 20	PROTECTIVE METAL SHEET RIGHT ☐ Code: M005+-M157;	1
260	A 220 423 00 71	SCREW PROTECTIVE PLATE TO STEERING KNUCKLE; M6X12 ☐ Code: -(M157+M005);	6