

Code :	Designation :	Position :
A0	Color code key	56D
A60/1	Mirror taximeter	54L
A7/3	Traction system hydraulic unit	26
A7/3	Traction system hydraulic unit	2A
A7/3b1	Front axle brake pressure sensor	2B
A7/3m1	High pressure and return pump	3C
A7/3y10	Left rear pressure regulator valve (pressure hold)	2E
A7/3y11	Left rear pressure regulator valve (pressure release)	3E
A7/3y12	Right rear pressure regulator valve (pressure hold)	2D
A7/3y13	Right rear pressure regulator valve (pressure release)	3D
A7/3y18	Front axle switchover valve	2D
A7/3y19	Rear axle switchover valve	3D
A7/3y22	Front axle intake ball valve	2C
A7/3y23	Rear axle intake ball valve	3C
A7/3y6	Left front pressure regulator valve (pressure hold)	2F
A7/3y7	Left front pressure regulator valve (pressure release)	3F
A7/3y8	Right front pressure regulator valve (pressure hold)	2E
A7/3y9	Right front pressure regulator valve (pressure release)	3E
B24/15	Yaw rate sensor for lateral and longitudinal acceleration	39L
B64/1	Brake vacuum sensor	28L
CAN E	Chassis CAN	41K
Code 4U7	Start/stop voltage dip protection	4H
Code B03	ECO start/stop function	4J
F32	Front electrical prefuse box	6L
F32f158	Prefuse 158	8K
F32f159	Prefuse 159	5K
F32f160	Prefuse 160	8K
F32f161	Prefuse 161	5K
L6/1	Left front axle rpm sensor	34L
L6/2	Left front axle rpm sensor	32L
L6/3	Left rear axle rpm sensor	37L
L6/4	Right rear axle rpm sensor	35L
NI0/1	Front SAM control unit with fuse and relay module	16L
NI0/1f1	Fuse 1	11L
NI0/1f14	Fuse 14	14L
NI0/1f20	Fuse 20	12L
NI0/1f21	Fuse 21	15L
NI0/2	Rear SAM control unit with fuse and relay module	24L
N30/4	Electronic Stability Program control unit	4A

Document number : pe42.47-p-2000-97daa
Document title : Wiring diagram for Adaptive Brake (ABR)

Code :	Designation :	Position :
N30/4	Electronic Stability Program control unit	20A
N30/4	Electronic Stability Program control unit	12A
N30/4	Electronic Stability Program control unit	28A
N30/4	Electronic Stability Program control unit	36A
N30/4	Electronic Stability Program control unit	44A
N30/4	Electronic Stability Program control unit	52A
M41/1	Navigation processor	50L
S10/2	Right front brake wear sensor	18L
S10/2x1	Right front brake wear sensor electrical connector	18K
S10/4	Right rear brake wear sensor	20L
S10/4x1	Right rear brake wear sensor electrical connector	20K
S9/1	Stop lamp switch	21L
U1018	Valid for gasoline engine 276	21L
U1032	Valid for engine 278 and 157	47E
U12	Valid for left-hand drive vehicles	47F
U127	Valid for combustion engines 272 and 273 KE	10E
U13	Valid for right-hand drive vehicles	42F
U152	Valid for gasoline engine 156	4E
U157	Valid for combustion engine 272 DE	45E
U221	Valid for China	42F
U222	Valid for Korea	49F
U223	Valid for external navigation	49F
U240	Valid for all except ECO start/stop function	49E
U243	Valid for diesel engine 651 with all-wheel drive	4H
U249	Valid for diesel engine 651 without all-wheel drive	44F
U252	Valid for ECO start/stop function	44F
U682	Valid for mirror taximeter	27E
U739	Valid for gasoline engine 271 DE	52E
U77	Valid for speed-sensitive power steering	42E
U880	Valid for diesel engine 642	42E
W19	Right front seat crossmember ground point	29E
W2	Right front ground point at lamp unit	44E
W70	Electronic Stability Program ground point	20E
X1/55	External navigation electrical connector	18E
X11/4	Diagnostic connector	11D
X18/33	Speed-sensitive power steering electrical connector	49H
X26	Interior and engine wiring harness electrical connector	23H
X26	Interior and engine wiring harness electrical connector	29H
X26	Interior and engine wiring harness electrical connector	42H
X26	Interior and engine wiring harness electrical connector	44H
X26	Interior and engine wiring harness electrical connector	46H

Document number : pe42.47-p-2000-97daa
Document title : Wiring diagram for Adaptive Brake (ABR)

Code :	Designation :	Position :
X26	Interior and engine wiring harness electrical connector	47H
X30/30	Vehicle floor chassis CAN voltage distributor electrical connector	41L
X62/32	Rear axle electrical connector, left distributor	36H
X62/33	Rear axle electrical connector, right distributor	19H
X62/33	Rear axle electrical connector, right distributor	35H
X62/6	Front axle electrical connector, right distributor	18H
X62/6	Front axle electrical connector, right distributor	31H
X62/7	Front axle electrical connector, left distributor	33H
Y10	Speed-sensitive power steering solenoid valve	30L
Y10/1	Power steering pump quantity control valve	45L
Z9/6	Travel distance signal connector sleeve 1	50E

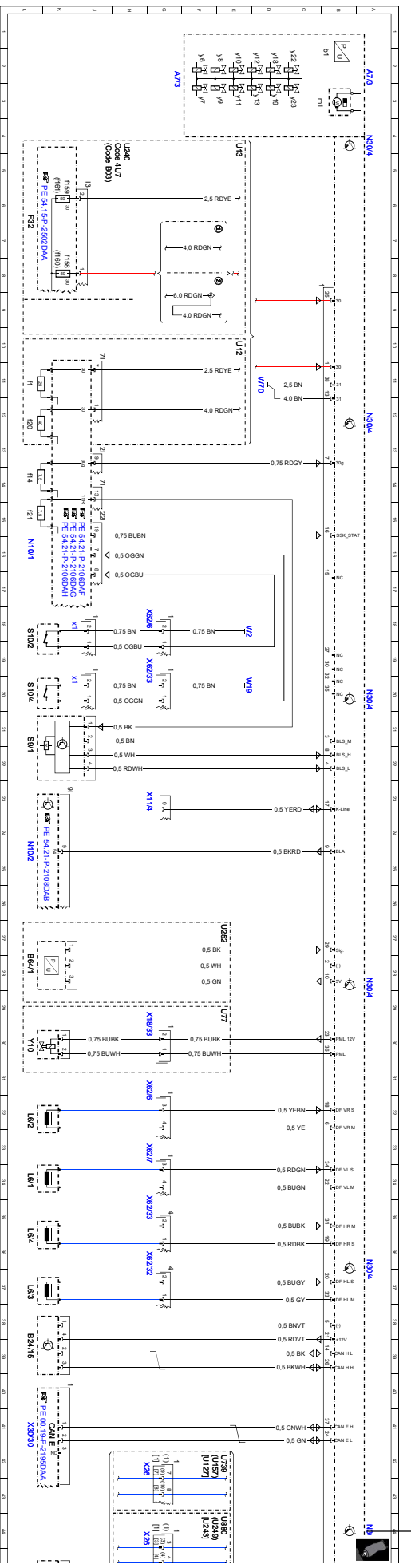

▲ Affix page 2 here ▼

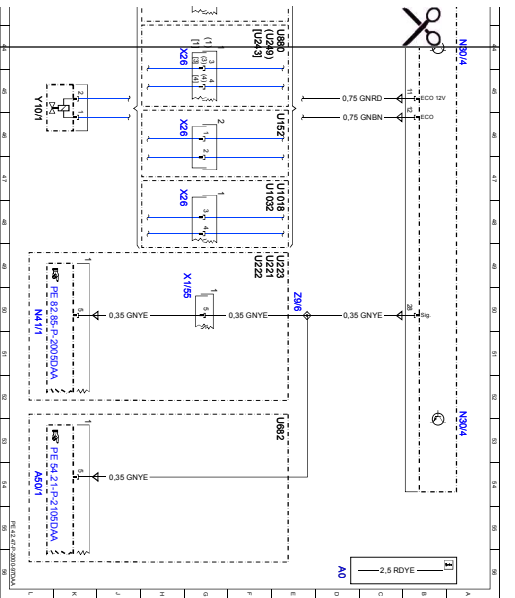

Cut here