

MODEL 212

**Model 212 (except model 212.095/098/298) without code (B03)
ECO start/stop function:**

- 1 Jump-starting point
- F32 Front electrical prefuse box

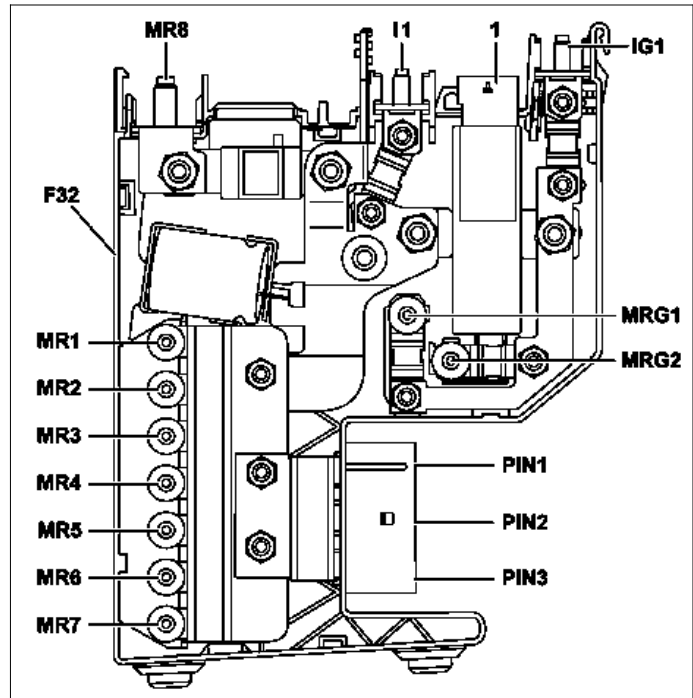

P54.15-3383-12

Fuse	Connector - designation	Circuit	Line ID (line fused)	Fused function	Rating in amperes (A)
f150	MR8	30	–	● Pyrofuse 150 (F32f150) triggered by Supplemental Restraint System control unit (N2/10)	–
f151	MR1	30	12.0 RD	● Electrical power steering control unit (N68)	50
f152	MR2	30	–	● Reserve	–
f153	MR3	30	–	● Reserve	–
f154	MR4	30	10.0 RD	Valid for 650-watt fan motor: ● Internal combustion engine and air conditioning fan motor with integrated control (M4/7)	100
			12.0 RD	Valid for 800-watt fan motor: ● Internal combustion engine and air conditioning fan motor with integrated control (M4/7)	
f155	MR5	30	16.0 RD	Valid for diesel engine: ● PTC heater booster (R22/3)	150
f156	MR6	30	6.0 RD	● Front SAM control module with fuse and relay module (N10/1)	60
f157	MR7	30	16.0 RD	● Front SAM control module with fuse and relay module (N10/1)	150
f158	PIN1	30	4.0 RD	Valid for left-hand drive vehicles: ● Blower regulator (A32n1)	50
			4.0 RDGN	Valid for right-hand drive vehicles and model 212 (except 212.074/077/092/095/098/274/277/292/298) without code (233) DISTRONIC PLUS: ● Electronic Stability Program control unit (N30/4)	
			4.0 RDGN	Valid for right-hand drive vehicles and model 212 (except 212.095/098/298) with code (233) DISTRONIC PLUS, model 212.074/077/092/274/277/292: ● Premium Electronic Stability Program control unit (N30/7)	

f159	PIN2	30	2.5 RDYE	Valid for right-hand drive vehicles and model 212 (except 212.074/077/092/095/098/274/277/292/298) without code (233) DISTRONIC PLUS: ● Electronic Stability Program control unit (N30/4)	50
			4.0 RDYE	Valid for right-hand drive vehicles and model 212 (except 212.095/098/298) with code (233) DISTRONIC PLUS, model 212.074/077/092/274/277/292: ● Premium Electronic Stability Program control unit (N30/7)	
f160	PIN3	30	6.0 RD	Valid for code (489) AIRmatic (air suspension with continuous adjustment damping) or with code (488) Steel/air suspension ● AIRmatic relay (K67)	60
f161	MRG1	30g	–	● Reserve	–
f162	MRG2	30g	10.0 RDWH	● Front SAM control module with fuse and relay module (N10/1)	100
f163	IG1	30g	16.0 RD	● Rear SAM control unit with fuse and relay module (N10/2)	150
f164	I1	30	16.0 RD	● Rear SAM control unit with fuse and relay module (N10/2)	100

With code (B03) ECO start/stop function:

- 1 Jump-starting point
- F32 Front electrical prefuse box

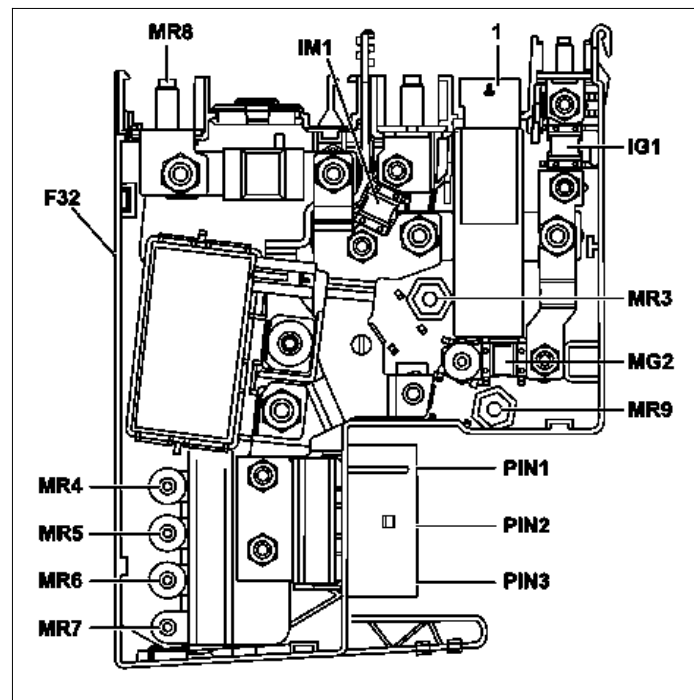

P54.15-3503-12

Fuse	Connector - designation	Circuit	Line ID (line fused)	Fused function	Rating in amperes (A)
f150	MR8	30	–	● Alternator (G2) ● Starter (M1)	350
f151	MR1	30	12.0 RD	● Internal combustion engine and air conditioning fan motor with integrated control (M4/7)	100
f152	MR2	30	16.0 RD	Valid for diesel engine: ● PTC heater booster (R22/3)	150
f153	MR3	30	–	● Reserve	–
f154	MR4	30	12.0 RD	● Front SAM control module with fuse and relay module (N10/1)	150
f155	MR5	30	–	● Reserve	–
f156	MR6	30	12.0 RD	● Front SAM control module with fuse and relay module (N10/1)	100
f157	MR7	30	12.0 RD	● Electrical power steering control unit (N68)	80

f159	PIN2	30	16.0 RD	● Rear SAM control unit with fuse and relay module (N10/2)	200
f160	PIN3	30	4.0 RD	Valid for left-hand drive vehicles: ● Blower regulator (A32n1)	50
			4.0 RD	Valid for right-hand drive vehicles and model 212 (except 212.074/ 077/092/095/098/274/277/292/298) without code (233) DISTRONIC PLUS: ● Electronic Stability Program control unit (N30/4)	
			4.0 RD	Valid for right-hand drive vehicles and model 212 (except 212.095/098/298) with code (233) DISTRONIC PLUS, model 212.074/077/092/274/277/292: ● Premium Electronic Stability Program control unit (N30/7)	
f161	MRG1	30	4.0 RD	Valid for left-hand drive vehicles with code (965) Electrical preinstallation for rental vehicle: ● Special-purpose vehicle multifunction control unit (N26/9)	50
			4.0 RD	Valid for right-hand drive vehicles and model 212 (except 212.074/077/092/095/098/274/277/292/298) without code (233) DISTRONIC PLUS: ● Electronic Stability Program control unit (N30/4)	
			4.0 RD	Valid for right-hand drive vehicles and model 212 (except 212.095/098/298) with code (233) DISTRONIC PLUS, model 212.074/077/092/274/277/292: ● Premium Electronic Stability Program control unit (N30/7)	
f162	MRG2	30	6.0 RD	Valid for code (489) AIRmatic (air suspension with continuous adjustment damping) or with code (488) Steel/air suspension ● AIRmatic relay (K67)	60
f163	IG1	30	–	● Reserve	–
f164	I1	30	–	● Reserve	–

Model 212.095/098/298:

- 1 Jump-starting point
F32 Front electrical prefuse box

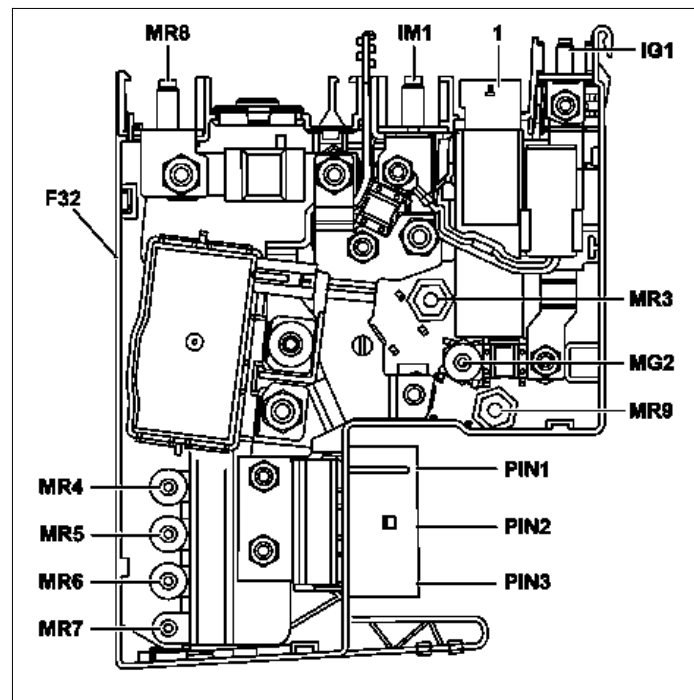

P54.15-3504-12

Fuse	Connector - designation	Circuit	Line ID (line fused)	Fused function	Rating in amperes (A)
f150	MR8	30	–	● Pyrofuse 150 (F32f150) triggered by Supplemental Restraint System control unit (N2/10)	–
f151	MR1	30	12.0 RD	● Internal combustion engine and air conditioning fan motor	100

f152	MR2	30	16.0 RD	Valid for diesel engine: ● PTC heater booster (R22/3)	150
f153	MR3	30	–	● Reserve	–
f154	MR4	30	12.0 RD	● Front SAM control module with fuse and relay module (N10/1)	150
f155	MR5	30	–	● Reserve	–
f156	MR6	30	12.0 RD	● Front SAM control module with fuse and relay module (N10/1)	100
f157	MR7	30	12.0 RD	● Electrical power steering control unit (N68)	80
f158	PIN1	30	16.0 RD	● Rear SAM control unit with fuse and relay module (N10/2)	150
f159	PIN2	30	–	● Reserve	–
f160	PIN3	30	4.0 RD	Valid for left-hand drive vehicles: ● Blower regulator (A32n1)	50
			4.0 RD	Valid for right-hand drive vehicles: ● Regenerative braking system control unit (N30/6)	
f161	MRG1	30g	4.0 RD	Valid for left-hand drive vehicles with code (965) Electrical preinstallation for rental vehicle: ● Special-purpose vehicle multifunction control unit (N26/9)	50
f162	MRG2	30g	6.0 RD	Valid for code (489) AIRmatic (air suspension with continuous adjustment damping) or with code (488) Steel/air suspension ● AIRmatic relay (K67)	60
			6.0 RD	Valid for right-hand drive vehicles: ● Regenerative braking system control unit (N30/6)	
f163	IG1	30g	–	● Reserve	–
f164	I1	30	–	● Reserve	–