

MODEL 212

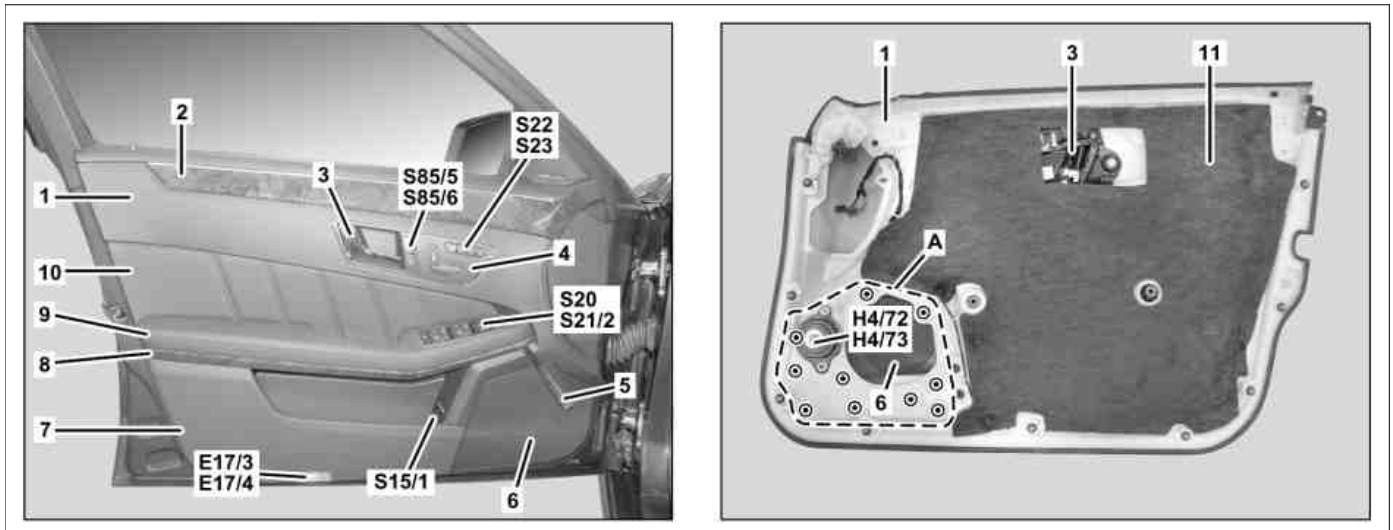

P72.10-3706-08

Shown on door lining (1) with code (275)

Memory package for electrically adjustable front seats and code (810)

Sound system

- 1 Door lining
- 2 Trim strip
- 3 Inside door opener
- 4 Panel
- 5 Mounting wedge
- 6 Speaker cover
- 7 Door pocket
- 8 Trim strip
- 9 Armrest
- 10 Center field
- 11 Mat cover

- E17/3 Left front door exit and warning lamp
- E17/4 Right front door exit and warning lamp
- H4/72 Left front door sound system tweeter and woofer with code (810) Sound system)
- H4/73 Right front door sound system tweeter and woofer (with code (810) Sound system)
- S15/1 Trunk lid release button
- S20 Driver-side power window and outside mirror adjustment switch group
- S21/2 Passenger-side power window switch
- S22 Left front seat adjustment switch group (with code (275) Memory package for electrically adjustable front seats)
- S23 Right front seat adjustment switch group (with code (275) Memory package for electrically adjustable front seats)
- S85/5 Left front door central locking interior switch
- S85/6 Right front door central locking interior switch

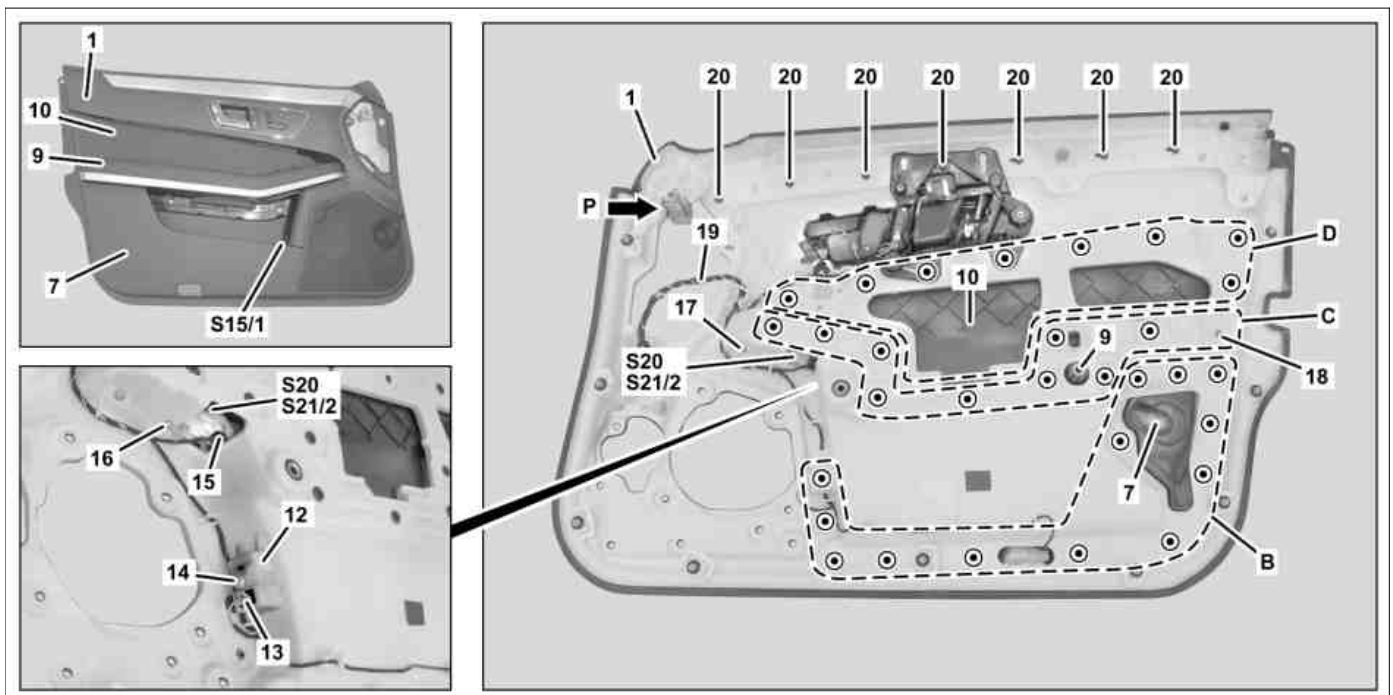

P72.10-3708-09

- 1 Door lining
- 7 Door pocket
- 15 Electrical connector
- 16 Screw
- S15/1 Trunk lid release button
- S20 Driver-side power window and

- 9 Armrest
- 10 Center field
- 12 Bracket
- 13 Electrical connector
- 14 Screw

- 17 Screw
- 18 Screw
- 19 Wiring harness
- 20 Screw

- S21/2 outside mirror adjustment switch group
- S22 Passenger-side power window switch
- S23

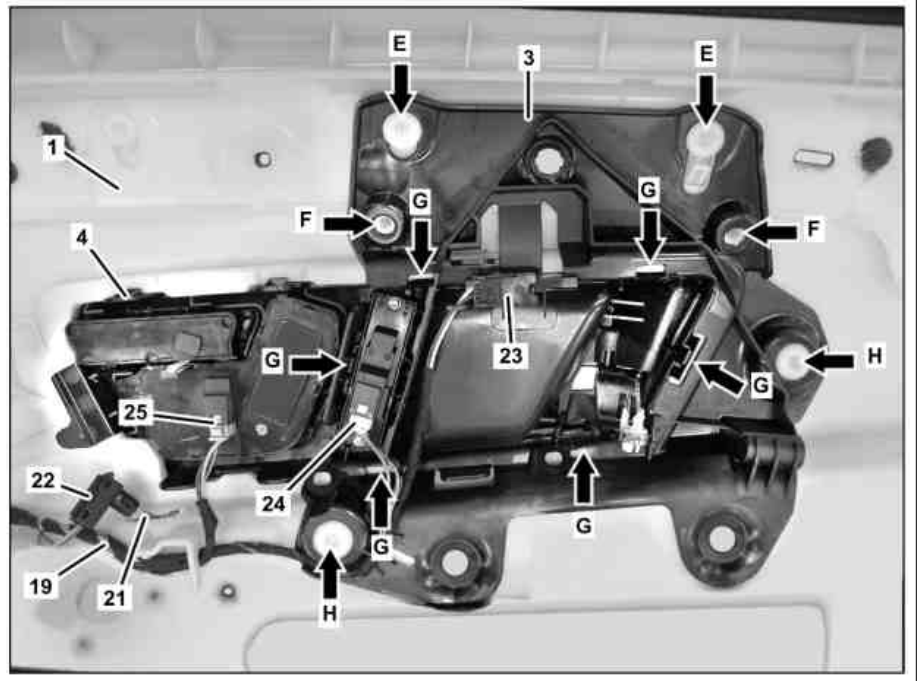
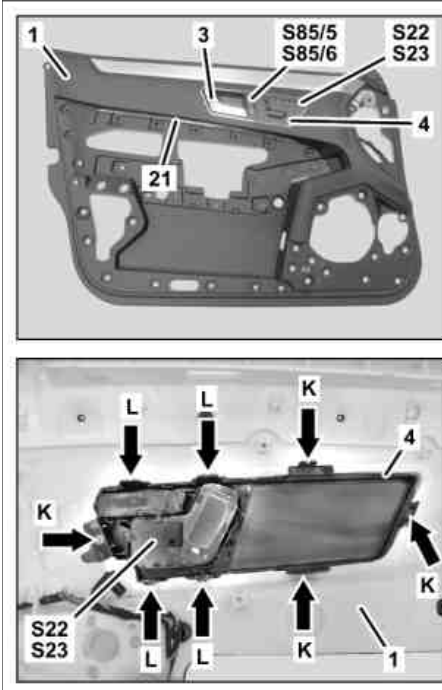

P72.10-3710-09

Shown on door lining (1) with code (275) Memory package for electrically adjustable front seats and code (955) Elegance

- 1 Door lining
- 3 Inside door opener
- 4 Panel
- 19 Wiring harness
- 21 Bar of light (with code (954) Avantgarde or code (955) Elegance)

- 22 Electrical connector (with code (954) Avantgarde or code (955) Elegance)
- 23 Electrical connector
- 24 Electrical connector
- 25 Electrical connector (with code (275) Memory package for electrically adjustable front seats)

- S22 Left front seat adjustment switch group (with code (275) Memory package (electrically adjustable front seats))
- S23 Right front seat adjustment switch group (with code (275) Memory package for electrically adjustable front seats)
- S85/5 Left front door central locking interior switch
- S85/6 Right front door central locking interior switch

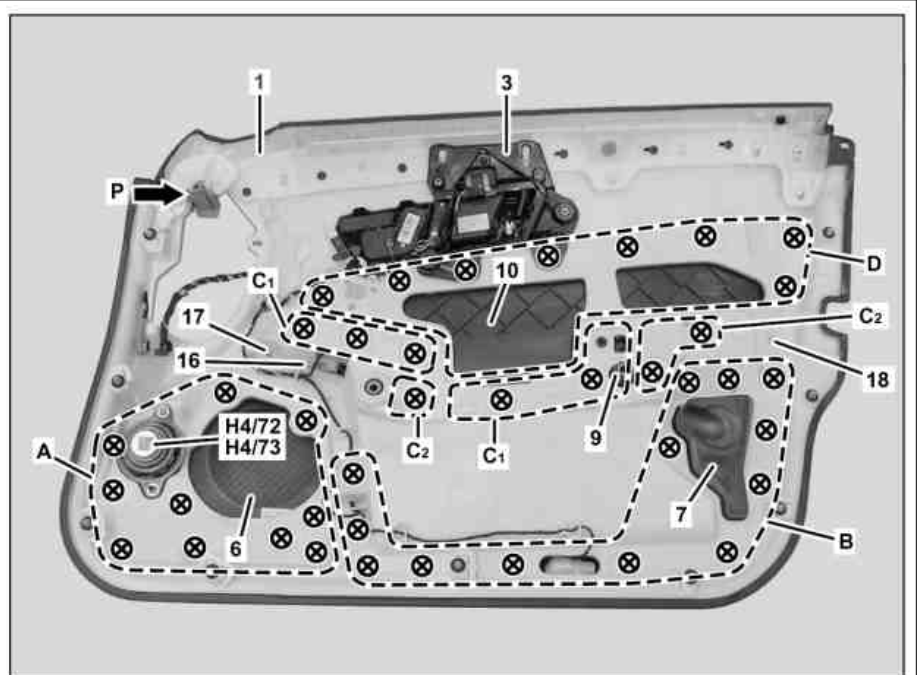
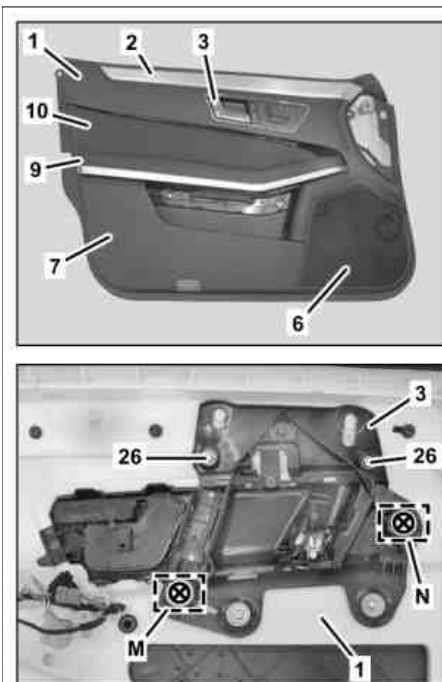

Shown on door lining (1) with code (810)**Sound system**

1	Door lining	10	Center field
2	Trim strip	16	Screw
3	Inside door opener	17	Screw
6	Speaker cover	18	Screw
7	Door pocket	26	Screw
9	Armrest		



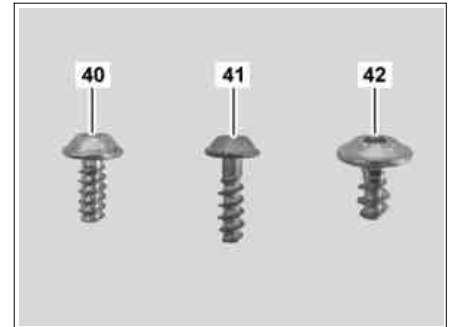

H4/72 Left Right front door sound system tweeter and woofer with code (810) Sound system

H4/73 Right front door sound system tweeter and woofer (with code (810) Sound system)







40	Bolt (EJOT DELTA PT ® K50x12)
41	Bolt (EJOT DELTA PT ® K50x16)
42	Bolt (EJOT DELTA PT ® K60x12)



P72.10-3724-01

	Disassemble		
1	Unclip trim strip (8) from armrest (9) with assembly wedge (5) starting at front	When replacing trim strip (8).	 *110589035900
2	Unclip left front door exit and warning lamp (E17/3) or right front door exit and warning lamp (E17/4) from door pocket (7) and disconnect electrical connectors	When replacing left front door exit and warning lamp (E17/3) or right front door exit and warning lamp (E17/4).	 *110589035900
3	Remove door lining (1) and place on suitable subsurface with front side down		AR72.10-P-1000CW
4	Remove left front door sound system center tone and bass speaker (H4/72) or right front door sound system tweeter and woofer (H4/73) from door lining (1)	On vehicles with code (810) Sound system	
5.1	Cut out plastic spot welds (area A) and remove speaker cover (6) from door lining (1).	When initially removing speaker cover (6).  Observe drilling and cutting depth; danger of drilling through.  Bonded spots in the plastic (area A) which have form while bonding the plastic, must be drilled out with a Ø 4.5 mm bit. Operate cordless drill with spot facer for cutting out plastic bonding points (area A) at high speed and low forward motion. Rechargeable drill / screwdriver gotis://G_58.0_01.1 Spot facer gotis://K_58.3_10.1	
5.2	Unscrew bolts (area A), remove washers and speaker cover (6) from door lining (1)	When removing speaker cover (6).	
6	Remove mat cover (11) from door lining (1)	 Mat cover (11) is replaced.	
7	Disconnect electrical connector (13), unscrew bolt (14) and remove trunk lid release button (S15/1) from door lining (1)	When disassembling door lining (1) on driver door.	
8	Unclip bracket (12) on trunk lid release button (S15/1) from door lining (1)	When disassembling door lining (1) on driver door.	
9	Unscrew bolt next to electrical connector (15) on passenger side power window switch (S21/2)	When disassembling door lining (1) on passenger door.	
10	Disconnect electrical connector (15) from driver side power window and outside mirror adjustment switch group (S20) or passenger side power window switch (S21/2)		
11	Unscrew bolt (16)		
12	Remove driver side power window and outside mirror adjustment switch group (S20) or passenger side power window switch (S21/2) from armrest (9)	When replacing driver side power window and outside mirror adjustment switch group (S20) or passenger side power window switch (S21/2).	

13.1	Cut out plastic spot welds (area B) and remove door pocket (7) from door lining (1)	When initially removing door pocket (7). ⚠ Observe drilling and cutting depth; danger of drilling through. ℹ Bonded spots in the plastic (area B) which have form while bonding the plastic, must be drilled out with a Ø 4.5 mm bit. Operate cordless drill with spot facer for cutting out plastic bonding points (area B) at high speed and low forward motion. Rechargeable drill / screwdriver gotis://G_58.0_01.1 Spot facer gotis://K_58.3_10.1	
13.2	Unscrew bolts (area B), remove washers and door pocket (7) from door lining (1)	When replacing door pocket (7).	
14	Unscrew bolt (17, 18) on armrest (9)		
15.1	Cut out plastic spot welds (area C) and remove armrest (9) from door lining (1)	When initially removing armrest (9). ⚠ Observe drilling and cutting depth; danger of drilling through. ℹ Bonded spots in the plastic (area C) which have form while bonding the plastic, must be drilled out with a Ø 4.5 mm bit. Operate cordless drill with spot facer for cutting out plastic bonding points (area C) at high speed and low forward motion. Rechargeable drill / screwdriver gotis://G_58.0_01.1 Spot facer gotis://K_58.3_10.1	
15.2	Unscrew bolts (area C ₁ , C ₂), remove washers and armrest (9) from door lining (1)	When replacing armrest (9).	
16.1	Cut out plastic spot welds (area D) and center field (10) from door lining (1)	When initially removing center field (10). ⚠ Observe drilling and cutting depth; danger of drilling through. ℹ Bonded spots in the plastic (area D) which have form while bonding the plastic, must be drilled out with a Ø 4.5 mm bit. Operate cordless drill with spot facer for cutting out plastic bonding points (area D) at high speed and low forward motion.. Rechargeable drill / screwdriver gotis://G_58.0_01.1 Spot facer gotis://K_58.3_10.1	
16.2	Unscrew bolts (area D), remove washers and center field (10) from door lining (1)	When again removing center field (10).	
17	Unscrew bolts (20) and remove trim strip (2) from door lining (1)	⚠ Do not use cordless drill/driver to prevent damaging the trim strip (2).	
18.1	Cut out plastic spot welds (arrows E, arrows H) from inside door opener (3)	When initially removing inside door opener (3). ⚠ Observe drilling and cutting depth; danger of drilling through. ℹ Bonded spots in the plastic (arrows E, arrows H) which have form while bonding the plastic, must be drilled out with a Ø 4.5 mm bit. Operate cordless drill with spot facer for cutting out plastic bonding points (arrows E, arrows H) at high speed and low forward motion.. Rechargeable drill / screwdriver gotis://G_58.0_01.1 Spot facer gotis://K_58.3_10.1	
18.2	Unscrew bolts (26) and bolts from attachment points (area M, N) on inside door opener (3) and remove washers from door lining (1)	When again removing inside door opener (3).	
19	Disconnect electrical connector (23) from inside door opener (3)		

20	Disconnect electrical connector (24) from front door central locking inside door opener switch (S85/5) or right front door central locking inside door opener switch (S85/6)		
21	Unclip left front door central locking inside door opener switch (S85/5) or right front door central locking inside door opener switch (S85/6) from inside door opener (3)	When replacing left front door central locking inside door opener switch (S85/5) or right front door central locking inside door opener switch (S85/6).	
22	Unclip inside door opener (3) from catch hooks (arrows G) and remove inside door opener (3) from door lining (1)		
23	Disconnect electrical connector (25) from left front seat adjustment switch group (S22) or right front seat adjustment switch group (S23)	On vehicles with code (275) Memory package for electrically adjustable front seats	
24	Unclip left front seat adjustment switch group (S22) or right front seat adjustment switch group (S23) from cover (4)	When replacing left front seat adjustment switch group (S22) or right front seat adjustment switch group (S23), on vehicles with code (275) Memory package for electrically adjustable front seats.	
25.1	Unclip cover (4) from catch hooks (arrows K) and remove from door lining (1)	On vehicles without code (275) Memory package for electrically adjustable front seats	
25.2	Unclip cover (4) from catch hooks (arrows K, arrows L) and remove from door lining (1)	On vehicles with code (275) Memory package for electrically adjustable front seats	
26	Disconnect electrical connector (22) and remove bar of light (21) from door lining (1)	In vehicles with Code (954) Avantgarde or Code (955) Elegance	
27	Remove electrical wiring harness (19) from door lining (1)		
28	Mark installation position of fastening bolt (arrow P) of height adjustment, then unclip fastening bolt (arrow P) from door lining (1)		
	Assemble		
29	Clip fastening bolt (arrow P) of height adjustment into door lining (1)	 Observe installation position of fastening bolt (arrow P).	
30	Route electrical wiring harness (19) on door lining (1) and fasten	 Ensure that wiring harness (19) is routed correctly.	
31	Insert bar of light (21) into door lining (1) and connect electrical connector (22)	In vehicles with Code (954) Avantgarde or Code (955) Elegance	
32	Clip cover (4) into door lining (1)		
33	Clip left front seat adjustment switch group (S22) or right front seat adjustment switch group (S23) into cover (4)	When replacing left front seat adjustment switch group (S22) or right front seat adjustment switch group (S23), on vehicles with code (275) Memory package for electrically adjustable front seats.	
34	Connect electrical connector (25) to left front seat adjustment switch group (S22) or right front seat adjustment switch group (S23)	On vehicles with code (275) Memory package for electrically adjustable front seats	
35	Clip inside door opener (3) into door lining (1)	 Ensure that inside door opener (3) is seated correctly.	
36	Clip left front door central locking inside door opener switch (S85/5) or right front door central locking inside door opener switch (S85/6) into inside door opener (3)	When replacing left front door central locking inside door opener switch (S85/5) or right front door central locking inside door opener switch (S85/6).	
37	Connect electrical connector (24) to left front door central locking inside door opener switch (S85/5) or right front door central locking inside door opener switch (S85/6)		
38	Connect electrical connector (23) to inside door opener (3)		
39	Screw bolts (26) to attachment bolts (arrows F) and bolts (40) with washers to attachment points (area M, N) on inside door opener (3) in door lining (1)		
40	Insert trim strip (2) into door lining (1) and tighten with bolts (20)		
41	Insert center field (10) flush into door lining (1)		
42	Cut out mounting domes (area D) on center field (10) next to door lining (1)	When replacing center field (10).  Observe cutting depth; danger of drilling through  Operate cordless drill with spot facer for cutting out mounting domes (area D) at high speed and low forward motion. Rechargeable drill / screwdriver gotis://G_58.0_01.1 Spot facer gotis://K_58.3_10.1	

43	Tighten center field (10) with bolts (40) and washers (area D)		
44	Insert armrest (9) flush into door lining (1)		
45	Cut out mounting domes (area C) on armrest (9) next to door lining (1)	When replacing armrest (9). ⚠️ Observe cutting depth; danger of drilling through ℹ️ Operate cordless drill with spot facer for cutting out mounting domes (area C) at high speed and low forward motion. Rechargeable drill / screwdriver gotis://G_58.0_01.1 Spot facer gotis://K_58.3_10.1	
46	Tighten armrest (9) with bolt (40) and washer (area C ₁) and bolt (41) with washer (area C ₂)		
47	Screw bolt (17, 18) into armrest (9)		
48	Insert door pocket (7) flush into door lining (1)		
49	Cut out mounting domes (area B) on door pocket (7) level with door lining (1)	When replacing door pocket (7). ⚠️ Observe cutting depth; danger of drilling through ℹ️ Operate cordless drill with flat facer for cutting out mounting domes (area B) at high speed and low forward motion. Rechargeable drill / screwdriver gotis://G_58.0_01.1 Spot facer gotis://K_58.3_10.1	
50	Tighten door pocket (7) with bolts (41) and washers (area B)		
51	Insert driver side power window and outside mirror adjustment switch group (S20) or passenger side power window switch (S21/2) into armrest (9)	When replacing driver side power window and outside mirror adjustment switch group (S20) or passenger side power window switch (S21/2).	
52	Screw in bolt (16)		
53	Connect electrical connector (15) to driver side power window and outside mirror adjustment switch group (S20) or passenger side power window switch (S21/2)		
54	Screw in bolt next to electrical connector (15) on passenger side power window switch (S21/2)	When assembling door lining (1) on passenger door.	
55	Clip bracket (12) on trunk lid release button (S15/1) into door lining (1)	When assembling door lining (1) on driver door.	
56	Insert trunk lid release button (S15/1) into door lining (1), screw in bolt (14) and connect electrical connector (13)	When assembling door lining (1) on driver door.	
57	Glue new mat cove (11) to door lining (1)	ℹ️ Transfer number and position of bonding points from old door lining (1). Special glue	*BR00.45-Z-1002-02A
58	Insert speaker cover (6) into door lining (1)		
59	Cut out mounting domes (area A) on speaker cover (6) level with door lining (1)	When replacing speaker cover (6). ⚠️ Observe cutting depth; danger of drilling through ℹ️ Operate cordless drill with spot facer for cutting out mounting domes (area A) at high speed and low forward motion. Rechargeable drill / screwdriver gotis://G_58.0_01.1 Spot facer gotis://K_58.3_10.1	
60	Tighten speaker cover (6) with bolts (42) and washers (area A)		
61	Install left front door sound system center tone and bass speaker (H4/72) or right front door sound system tweeter and woofer (H4/73) from door lining (1)	On vehicles with code (810) Sound system ⚠️ Do not tighten cutting nuts too tightly to prevent damaging mounting pins.	

		i If a cutting nut can no longer be tightened because the mounting pin is damaged, it is possible to press on a new suitable clamping plate as an alternative. It is important the left front door sound system center tone and bass speaker (H4/72) or right front door sound system tweeter and woofer (H4/73) are seated in the door line without play (1)	
62	Install door lining (1)		AR72.10-P-1000CW
63	Clip left front door exit and warning lamp (E17/3) or right front door exit and warning lamp (E17/4) into door pocket (7) and connect electrical connector	When replacing left front door exit and warning lamp (E17/3) or right front door exit and warning lamp (E17/4).	
64	Clip trim strip (8) into armrest (9)	When replacing trim strip (8).	

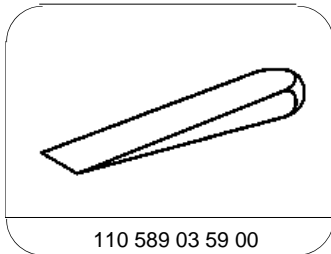

110 589 03 59 00

Mounting wedge

Repair materials

Number	Designation	Order number
BR00.45-Z-1002-02A	Adhesive Terokal 2444	A 000 989 92 71