

**Model 212**

Model 212 (except 212.095/098/298) except code B03 (ECO start/stop function)

F32 Front electrical prefuse box

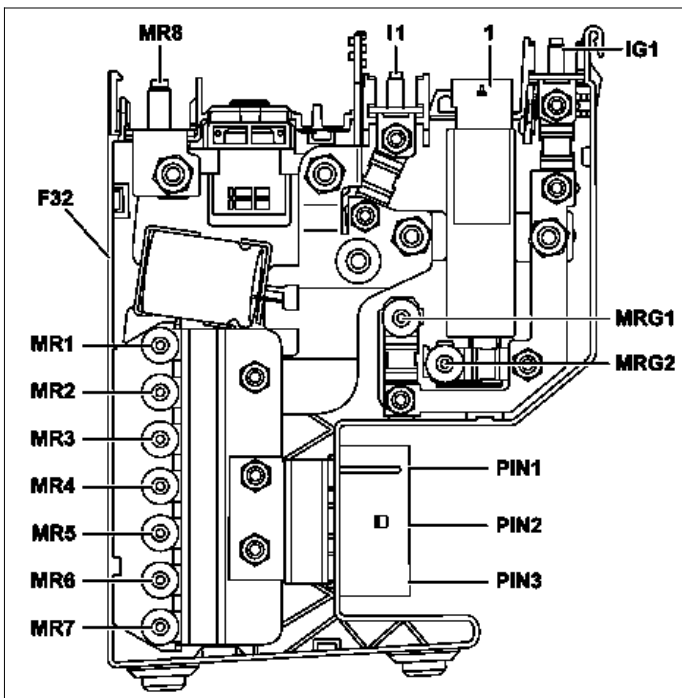

P54.15-3824-12

Connection	Fuse	Clamping device	Wire identification	Fused component	Rating in amperes (A)
MR8	Prefuse 150 (F32f150)	30	-	Pyrofuse, triggered by Supplemental Restraint System control unit (N2/10)	-
MR1	Prefuse 151 (F32f151)	30	12.0 RD	Electrical power steering control unit (N68)	50
MR2	Prefuse 152 (F32f152)	30	-	Spare	-
MR3	Prefuse 153 (F32f153)	30	-	Spare	-
MR4	Prefuse 154 (F32f154)	30	10.0 RD	<b>Valid for 650-watt fan motor:</b> Fan motor for internal combustion engine and air conditioning with integrated control (M4/7)	100
			12.0 RD	<b>Valid for 800-watt fan motor:</b> Fan motor for internal combustion engine and air conditioning with integrated control (M4/7)	
MR5	Prefuse 155 (F32f155)	30	16.0 RD	<b>Valid for diesel engine:</b> PTC heater booster (R22/3)	150
MR6	Prefuse 156 (F32f156)	30	6.0 RD	<b>Valid for front on-board electrical system battery (G1):</b> Front SAM control unit with fuse and relay module (N10/1)	60
MR7	Prefuse 157 (F32f157)	30	16.0 RD	Front SAM control unit with fuse and relay module (N10/1)	150
PIN1	Prefuse 158 (F32f158)	30	4.0 RD	<b>Valid for left-hand drive vehicles:</b> Blower regulator (A32n1)	50
			4.0 RDGN	<b>Valid for right-hand drive vehicles and model 212 (except 212.074/077/092/274/277/292) except code 233 (DISTRONIC PLUS):</b> Electronic Stability Program control unit (N30/4)	
			4.0 RDGN	<b>Valid for right-hand drive vehicles and model 212 with code 233 (DISTRONIC PLUS), model 212.074/077/092/274/277/292:</b> Premium Electronic Stability Program control unit (N30/7)	
PIN2	Prefuse 159 (F32f159)	30	2.5 RDYE	<b>Valid for right-hand drive vehicles and model 212 (except 212.074/077/092/274/277/292) except code 233 (DISTRONIC PLUS):</b> Electronic Stability Program control unit (N30/4)	50
			4.0 RDYE	<b>Valid for right-hand drive vehicles and model 212 with code 233 (DISTRONIC PLUS), model 212.074/077/092/274/277/292:</b> Premium Electronic Stability Program control unit (N30/7)	
PIN3	Prefuse 160 (F32f160)	30	6.0 RD	<b>Valid with code 489 (AIRMATIC) or code 488 (Steel/air suspension):</b> AIRmatic relay (K67)	60

				<b>Valid with transmission 725:</b> Fully integrated transmission control unit (Y3/8n4)	
MRG1	Prefuse 161 (F32f161)	30g	-	Spare	-
MRG2	Prefuse 162 (F32f162)	30g	10.0 RDWH	Front SAM control unit with fuse and relay module (N10/1)	100
IG1	Prefuse 163 (F32f163)	30g	16.0 RD	Rear SAM control unit with fuse and relay module (N10/2)	150
I1	Prefuse 164 (F32f164)	30	16.0 RD	<b>Valid for front on-board electrical system battery (G1):</b> Rear SAM control unit with fuse and relay module (N10/2)	100

Model 212 (except 212.095/098/298) with code B03 (ECO start/stop function)

F32 Front electrical prefuse box

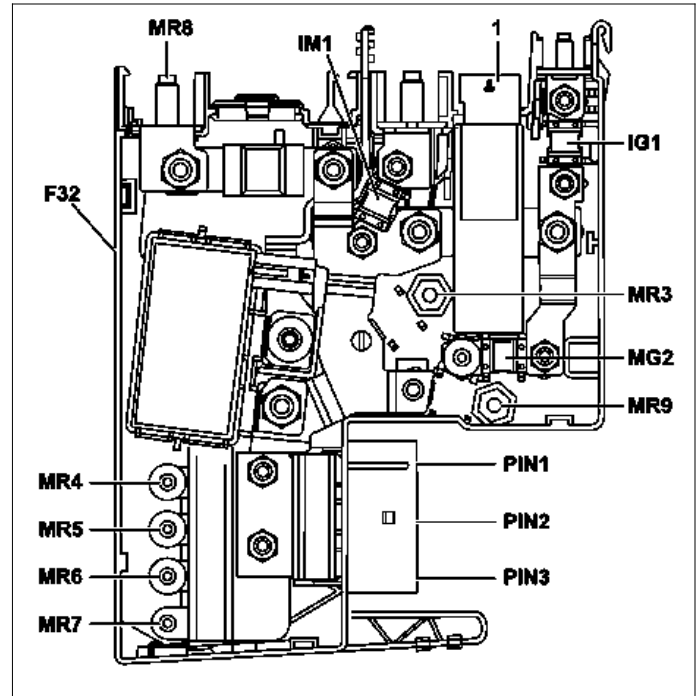

P54.15-3503-12

Connection	Fuse	Clamping device	Wire identification	Fused component	Rating in amperes (A)
MR8	Prefuse 150 (F32f150)	30	35.0 RD	Alternator (G2)	350
			10.0 RD	<b>Valid with CODE 228 (Stationary heater):</b> Stationary heater control unit (A6n1)	
MR4	Prefuse 151 (F32f151)	30	10.0 RD	<b>Valid for 650-watt fan motor:</b> Fan motor for internal combustion engine and air conditioning with integrated control (M4/7)	100
			12.0 RD	<b>Valid for 800-watt fan motor:</b> Fan motor for internal combustion engine and air conditioning with integrated control (M4/7)	
MR5	Prefuse 152 (F32f152)	30	16.0 RD	<b>Valid for diesel engine:</b> PTC heater booster (R22/3)	150
MR6	Prefuse 153 (F32f153)	30	6.0 RD	<b>Valid for front on-board electrical system battery (G1):</b> Front SAM control unit with fuse and relay module (N10/1)	60
MR7	Prefuse 154 (F32f154)	30	16.0 RD	Front SAM control unit with fuse and relay module (N10/1)	150
MR9	Prefuse 155 (F32f155)	30	-	Spare	-
MG2	Prefuse 156 (F32f156)	30g	12.0 RD	Front SAM control unit with fuse and relay module (N10/1)	100
MR3	Prefuse 157 (F32f157)	30	10.0 RDWH	Electrical power steering control unit (N68)	80
IG1	Prefuse 158 (F32f158)	30g	16.0 RD	Rear SAM control unit with fuse and relay module (N10/2)	150
IM1	Prefuse 159 (F32f159)	30	10.0 RD	<b>Valid for front on-board electrical system battery (G1):</b> Rear SAM control unit with fuse and relay module (N10/2)	100
PIN1	Prefuse 160 (F32f160)	30	4.0 RD	<b>Valid for left-hand drive vehicles:</b> Blower regulator (A32n1)	50
			4.0 RDGN	<b>Valid for right-hand drive vehicles and model 212 (except 212.074/077/092/274/277/292) except code 233 (DISTRONIC PLUS):</b> Electronic Stability Program control unit (N30/4)	

			4.0 RDGN	<b>Valid for right-hand drive vehicles and model 212 with code 233 (DISTRONIC PLUS), model 212.074/077/092/274/277/292:</b> Premium Electronic Stability Program control unit (N30/7)	
PIN2	Prefuse 161 (F32f161)	30	2.5 RDYE	<b>Valid for right-hand drive vehicles and model 212 (except 212.074/077/092/274/277/292) except code 233 (DISTRONIC PLUS):</b> Electronic Stability Program control unit (N30/4)	50
			4.0 RDYE	<b>Valid for right-hand drive vehicles and model 212 with code 233 (DISTRONIC PLUS), model 212.074/077/092/274/277/292:</b> Premium Electronic Stability Program control unit (N30/7)	
PIN3	Prefuse 162 (F32f162)	30	6.0 RD	<b>Valid with code 489 (AIRMATIC) or code 488 (Steel/air suspension):</b> AIRmatic relay (K67)	60
				<b>Valid with transmission 725:</b> Fully integrated transmission control unit (Y3/8n4)	

**Model 212.095/098/298**

F32 Front electrical prefuse box

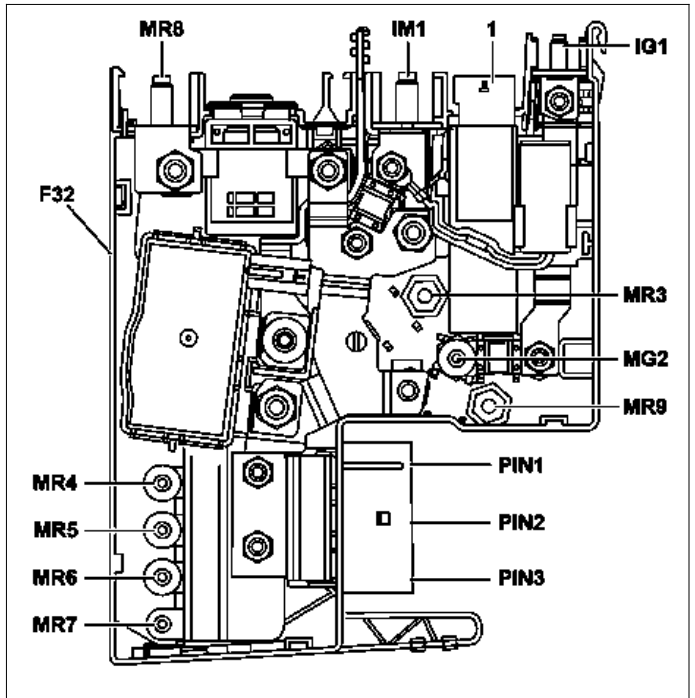

P54.15-3825-12

Connection	Fuse	Clamping device	Wire identification	Fused component	Rating in amperes (A)
MR8	Prefuse 150 (F32f150)	30	-	Pyrofuse, triggered by Supplemental Restraint System control unit (N2/10)	-
MR4	Prefuse 151 (F32f151)	30	10.0 RD	<b>Valid for 650-watt fan motor:</b> Fan motor for internal combustion engine and air conditioning with integrated control (M4/7)	100
			12.0 RD	<b>Valid for 800-watt fan motor:</b> Fan motor for internal combustion engine and air conditioning with integrated control (M4/7)	
MR5	Prefuse 152 (F32f152)	30	16.0 RD	<b>Valid for diesel engine:</b> PTC heater booster (R22/3)	150
MR6	Prefuse 153 (F32f153)	30	6.0 RD	<b>Valid for front on-board electrical system battery (G1):</b> Front SAM control unit with fuse and relay module (N10/1)	60
MR7	Prefuse 154 (F32f154)	30	16.0 RD	Front SAM control unit with fuse and relay module (N10/1)	150
MR9	Prefuse 155 (F32f155)	30	10.0 RD	HYBRID fuse and relay module (K40/10)	150
MG2	Prefuse 156 (F32f156)	30g	10.0 RDWH	Front SAM control unit with fuse and relay module (N10/1)	100
MR3	Prefuse 157 (F32f157)	30	12.0 RD	Electrical power steering control unit (N68)	80
IG1	Prefuse 158 (F32f158)	30g	16.0 RD	Rear SAM control unit with fuse and relay module (N10/2)	150
IM1	Prefuse 159 (F32f159)	30	10.0 RD	<b>Valid for front on-board electrical system battery (G1):</b> Rear SAM control unit with fuse and relay module (N10/2)	100
PIN1	Prefuse 160 (F32f160)	30	4.0 RD	<b>Valid for left-hand drive vehicles:</b> Blower regulator (A32n1)	50
			4.0 RDGN	<b>Valid for right-hand drive vehicles:</b> Regenerative braking system control unit (N30/6)	
PIN2	Prefuse 161 (F32f161)	30	4.0 RDYE	<b>Valid for right-hand drive vehicles:</b> Regenerative braking system control unit (N30/6)	50

PIN3	Prefuse 162 (F32f162)	30	6.0 RD	<b>Valid with code 489 (AIRMATIC) or code 488 (Steel/air suspension):</b> AIRmatic relay (K67)	60
------	--------------------------	----	--------	---	----