

Elektromotus CAN bus topology recommendations v0.2 rc2

Table of Contents

Introduction.....	1
Timing parameters.....	1
Topology aspects.....	3
Bus and drop line lengths.....	4
Bus termination.....	5
Number of nodes.....	6
Recommendations.....	6
References.....	7

Introduction

The controller area network (CAN) is a standard for distributed communications with built-in fault handling, specified for the physical and data link layers of the open system interconnection (OSI) model in ISO-11898. CAN has been widely adopted in industrial and instrumentation applications and the automotive industry due to inherent strengths of the communication mechanisms used by CAN.

A CAN bus topology is determined by the maximum allowed bus length, maximum length of unterminated drop lines connected to the main bus line and number of nodes.

Timing parameters

A CAN bus system uses a nominal bit rate f_{nbr} (in bits per second) which is uniform throughout the network.

Each node in a CAN network has to perform frequent „hard synchronization“ and „re-



synchronization“ in order to ensure correct data processing. For purpose of the synchronization, the CAN controller regards each bit period as being split to several segments as shown in Figure 1.

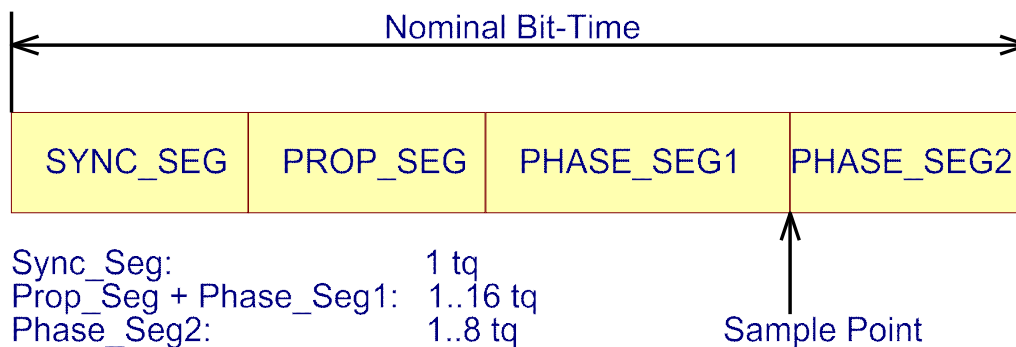

Fig. 1. CAN bit timing

The time in a CAN node is referred to a CAN system clock, the period of which is called „time quantum“ T_Q . ISO CAN norm requires that each bit period is split to 8-25 time quanta, which means that CAN system clock is 8-25 times faster than the nominal bit rate.

Each bit period begins with a SYNC_SEG, the duration of which is fixed to one T_Q . Transmitting node begins to drive the bus at the beginning of the SYNC_SEG, whereas a correctly synchronized receiving node expects every edge on the bus arriving during SYNC_SEG.

The bit period continues with a PROP_SEG, a period fixed by the CAN to 1-8 T_Q . It is the minimum time a receiver will wait before accepting a valid bus value sample. In other words PROP_SEG is used to compensate for signal delays across the network. Following segments PHASE_SEG1 and PHASE_SEG2 are periods of time which are adapted during the „re-synchronization“ in order to move the „sample point“. PHASE_SEG1 and PHASE_SEG2 are used to compensate for edge phase error. The maximum allowed modification of the PHASE_SEG1 and PHASE_SEG2 is referred to as SJW(synchronization jump width).

The bus state detected at the „sample point“ is accepted by the receiving node as logical value valid for the current bit period.

Table 1 provides EMUS BMS CAN bus bit timing parameters. Baud rate values, sampling point positions and maximum bus lengths are based on CAN in Automation(CiA) international users and manufacturers group documentation. Also, bit-timing values recommended in CiA documentation are such that nodes from different manufacturers can be connected to one CAN network.

Table 1. EMUS CAN bus bit timing parameters.

Baud rate	SYNC_SEG	PROP_SEG	PHASE_SEG1	PHASE_SEG2	Nominal bit time	Sampling Point
1 Mbit/s	1 T _Q	2 T _Q	3 T _Q	2 T _Q	1 μs	75,00 %
800 kbit/s	1 T _Q	3 T _Q	4 T _Q	2 T _Q	1,25 μs	80,00 %
500 kbit/s	1 T _Q	6 T _Q	7 T _Q	2 T _Q	2 μs	87,50 %
250 kbit/s	1 T _Q	6 T _Q	7 T _Q	2 T _Q	4 μs	87,50 %
125 kbit/s	1 T _Q	6 T _Q	7 T _Q	2 T _Q	8 μs	87,50 %
50 kbit/s	1 T _Q	8 T _Q	8 T _Q	3 T _Q	20 μs	85,00 %

Early sampling point decreases the sensitivity to the oscillator tolerances as different nodes are present on the same network. On the other hand, later sampling point allows to achieve longer bus line length: maximum signal propagation time (more T_Q in PROP_SEG). That means that longer maximum bus length can be achieved, also poor bus topologies can be handled. Elektromotus CAN bus does support later sampling point value as CiA documentation recommends.

Topology aspects

The high speed ISO 11898-2 CAN standard defines a single line structure network topology. CAN bus does not support star or even a multi star topologies. The nodes are connected via unterminated drop lines to the main bus. The bus line is terminated at both furthest ends with a single termination resistor(characteristic line impedance) as it is shown in Figure 2. Otherwise signal reflections will occur on the bus causing significant ringing and error rate. Bus topology must be chosen such that reflections will be minimized.

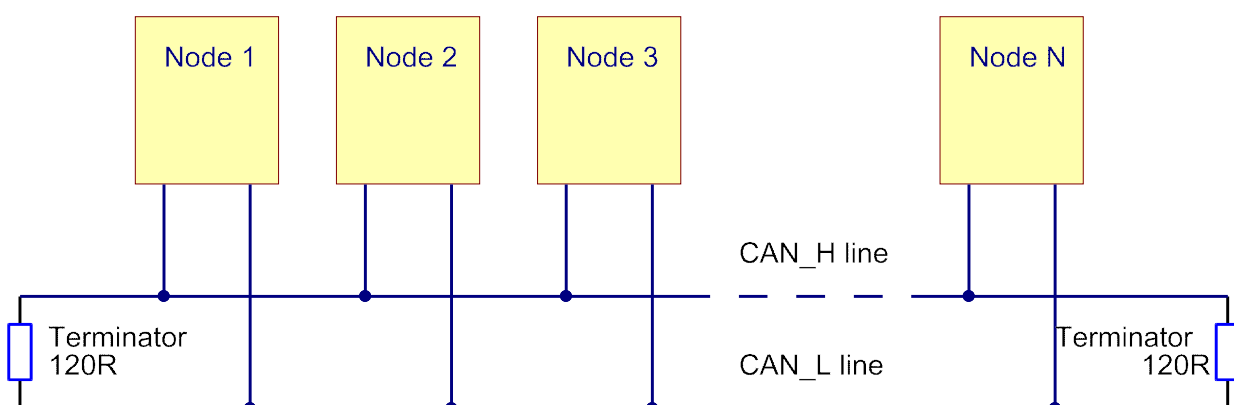

Fig. 2. Basic CAN bus topology.

Bus line length is limited by PROP_SEG duration, propagation delay Tx to Rx of the used CAN transceiver (transceivers delay) and bus line delay per unit length (typ. 5 ns/m). All in all, biggest limitation to the bus length is the transceivers propagation delay.

Unterminated drop lines do cause signal reflections. Although reflected signals will disappear once they arrive at a bus termination, and although the CAN protocol is robust, an upper limit must be set to the allowed unterminated drop line length as well as to the cumulative drop line length. Unterminated drop line length is determined by PROP_SEG duration and bus line delay per unit length (typ. 5 ns/m).

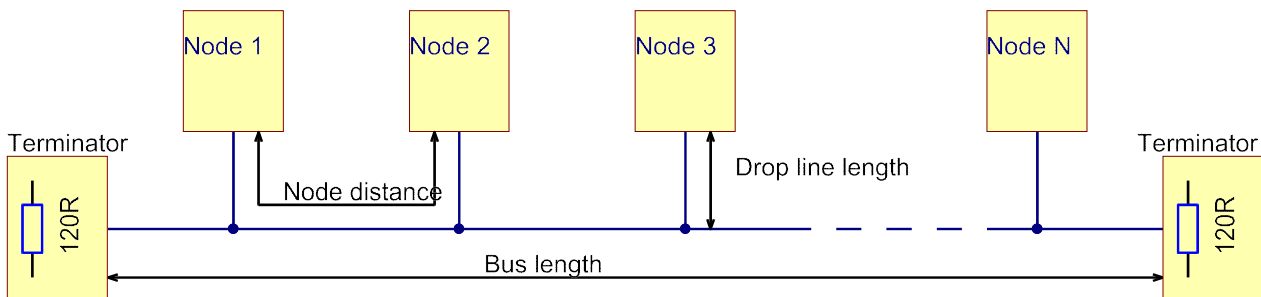

Fig. 3. CAN bus with unterminated drop lines.

Bus and drop line lengths

Maximum CAN bus and drop line lengths are presented in Table 2. Node distance is distance between two nodes and it must not exceed total bus length.

Table 2. Maximum bus line lengths.

Baud Rate	Propagation Segm.	Time quantum T_Q	L_U	$\sum L_U$	Bus length
1 Mbit/s	500 ns	125 ns	2 m	10 m	30 m
800 kbit/s	750 ns	125 ns	3 m	15 m	50 m
500 kbit/s	1500 ns	125 ns	6 m	30 m	100 m
250 kbit/s	3 μ s	250 ns	12 m	60 m	250 m
125 kbit/s	6 μ s	500 ns	24 m	120 m	500 m
50 kbit/s	15 μ s	1 μ s	60 m	300 m	1000 m

Table contents explanation:

- Propagation Segm. - propagation segment duration (calculated from Table 1);
- L_U - a single node maximum unterminated drop line length;
- $\sum L_U$ (m) – cumulative maximum length of all nodes drop lines length;

- Bus Length – terminated bus maximum line length.

For example the CAN bus network baud rate is 500 kbit/s. In case the full cumulative length of all unterminated drop lines is used (30 meters) then maximum bus line length is limited to 70 meters ($100-30 = 70$ meters).

Maximum bus line length values presented in Table 2 are based on timing parameters only. Another limitation on the CAN bus topology is defined by the amplitude of the bus voltage required for correct reception of the state. The signal amplitude is decreased by voltage drop along the bus line, as the bus is loaded by the termination resistors and finite input resistance of the nodes. Usually, network timing parameters have much higher impact on bus length compared to amplitude drop on the bus (CAN transceiver capabilities). For further reading refer to [1] application note. In case of EMUS BMS CAN transceiver does have capability to drive much longer bus lengths than determined by Table 2. Ultimately it falls down to CAN transceiver properties.

Bus termination

The physical layer characteristics for CAN are specified in ISO-11898-2. This standard specifies the use of cable comprising parallel wires with an impedance of nominally 120Ω (95Ω minimum and 140Ω maximum). The use of shielded twisted pair cable is generally necessary for electro-magnetic compatibility (EMS) reasons, although ISO-11898-2 also allows for unshielded cable.

For reliable CAN communication, it is essential that reflections in the transmission line would be kept as small as possible. This can be done only by proper cable termination. Signal reflections happen very quickly during and just after signal transitions. On a long line, the reflections are more likely to continue long enough to cause the receiver to misread logic levels. On short lines, the reflections occur much sooner and have no effect on the received logic levels.

In CAN applications, both ends of the bus must be terminated because any node on the bus may transmit data. Each end of the link has a termination resistor equal to the characteristic impedance of the cable, although the recommended value of the termination resistor is nominally 120Ω . There should be no more than two terminating resistors in the network, regardless of how many nodes are connected, because additional terminations place extra load on the CAN transceivers. ISO-11898-2 recommend not integrating a terminating resistor into a node but rather attaching standalone termination resistor at the furthest ends of the bus. This is to avoid a loss of a



termination resistor if node containing that resistor is disconnected. The concept also applies to avoiding the connection of more than two termination resistors to the bus, or locating termination resistors at other point in the bus rather than at two ends.

Number of nodes

Maximum number of nodes on the bus does depend on used CAN transceivers driving capability. It is specified by the minimum allowed load resistance. In case of EMUS BMS used CAN transceiver up to 112 nodes can be connected in one network if 120Ω termination resistors are used. However, total number of nodes depends on other devices on the network(CAN transceivers). So check that parameter in datasheet.

Recommendations

It is advised to keep away from absolute maximum bus and drop line lengths. Also, it is recommended to use 120Ω termination resistors. Note, that value of termination resistors can vary with bus length from 300Ω at very long bus lines to 100Ω at very short lines.

Recommendations are:

- Keep node count below 30;
- Design CAN network as close as possible to a single line structure;
- Do not exceed maximum allowed bus line length at certain speed;
- Place termination resistors (120Ω) to furthest points of a bus line;
- Keep maximum unterminated drop line length under 0,3 meters.

For example, we do have a network at 500 kbit/s speed and 30 nodes. If we keep all unterminated drop lines to nodes at 0,3 meters then total unterminated drop line length is 9 meters ($30 * 0,3 = 9$ meters). In that case, maximum terminated bus line length is $100-9=91$ meters. In reality, maximum terminated bus line length depends not only on timing parameters, but also on used wiring (wire resistance and signal amplitude). If we have same network but different baud rate, say 1 Mbit/s, the cumulative maximum unterminated drop line length is almost at its maximum. In that case maximum bus line length is only 21 meters ($30 - 9 = 21$ meters).

To keep it on a safe side, always design system that is considerably reduced in the bus speed or line length compared to the maximum limit. Just in case bus termination resistors do not match characteristic line impedance or low grade wiring is used. Note, that the value for the two-way bus

line propagation delay is related to the bus time constant, i.e. the capacitance of the entire network multiplied by effective discharge resistance (e.g. 60Ω). Also, there might be a ground offset between nodes which brings the capacitance discharge time issues (every line has its own capacitance) [2].

For more detailed description of CAN bus refer to documentation in reference.

References

1. AND8376 Application note, ON Semiconductor;
2. AN96116 Application note, Philips;
3. AN-1123 Application note, Analog Devices;
4. AN228 Application note, Microchip;
5. AN754 Application note, Microchip;
6. MCP2551 Datasheet, Microchip;
7. AN10211 Application note of TJA1040, NXP Semiconductors;
8. CiA DR-303-1 Draft Recommendations, CAN in Automation (CiA);
9. SLOA101A Application Report, Texas Instruments;
10. SLLA270 Application Report, Texas Instruments;
11. CiA303-1, CAN in Automation;

