

**Document title** AIRMATIC, block diagram

**Document number** gf3222p000306fl

**MODEL 212**

**with CODE 489 (AIRMATIC (air suspension with continuous damper adjustment))**

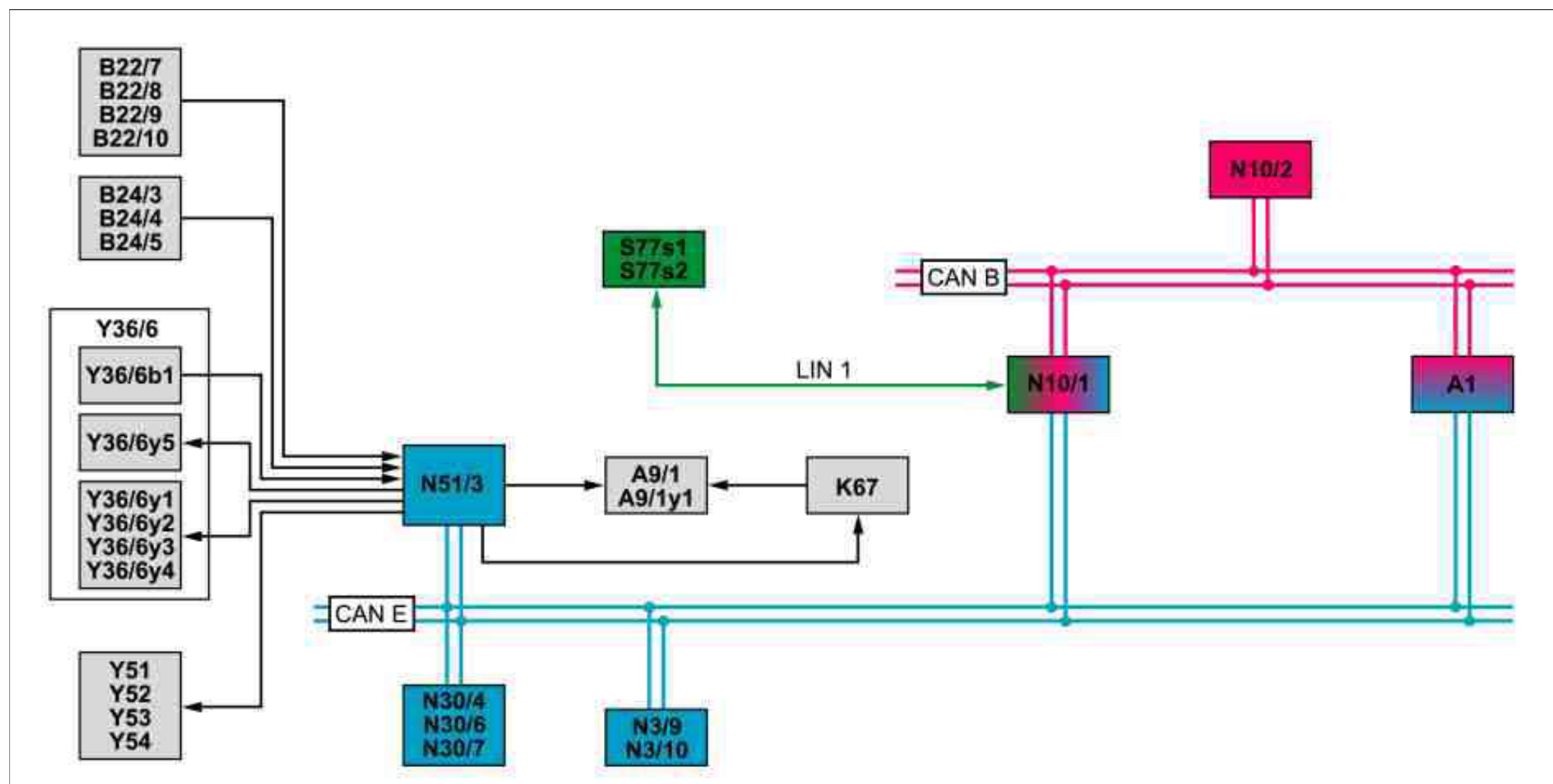

P32.22-2506-79

**Valid up to model year 2014**

A1	Instrument cluster	N3/10	ME-SFI [ME] control unit (with gasoline engine)	Y36/6y2	Right front level control valve
A9/1	AIRMATIC compressor	N10/1	Front SAM control unit with fuse and relay module	Y36/6y3	Left rear level control valve
A9/1y1	AIRMATIC pressure reduction valve	N10/2	Rear SAM control unit with fuse and relay module	Y36/6y4	Right rear level valve
B22/7	Left rear level sensor	N30/4	Electronic Stability Program control unit (except CODE 233 (DISTRONIC PLUS), except CODE 990 (AMG vehicles), except hybrid)	Y36/6y5	AIRMATIC central reservoir filling valve
B22/8	Left front level sensor	N30/6	Regenerative braking system control unit (for hybrid)	Y51	Left front axle damping valve unit
B22/9	Right front level sensor	N30/7	Premium Electronic Stability Program control unit (with CODE 233 (DISTRONIC PLUS) or with CODE 990 (AMG vehicles), except hybrid)	Y52	Right front axle damping valve unit
B22/10	Right rear level sensor	N51/3	AIRMATIC control unit	Y53	Left rear axle damping valve unit
B24/3	Left front body lateral acceleration sensor	S77s1	Electronic level control button	Y54	Right rear axle damping valve unit
B24/4	Right front body lateral acceleration sensor	S77s2	Comfort and Sport button	CAN B	Interior CAN
B24/5	Left rear body lateral acceleration sensor	Y36/6	AIRMATIC valve unit	CAN E	Chassis CAN
K67	AIRMATIC relay	Y36/6b1	AIRMATIC pressure sensor	LIN 1	Instrument panel LIN
N3/9	CDI control unit (with diesel engine)	Y36/6y1	Left front level control valve		

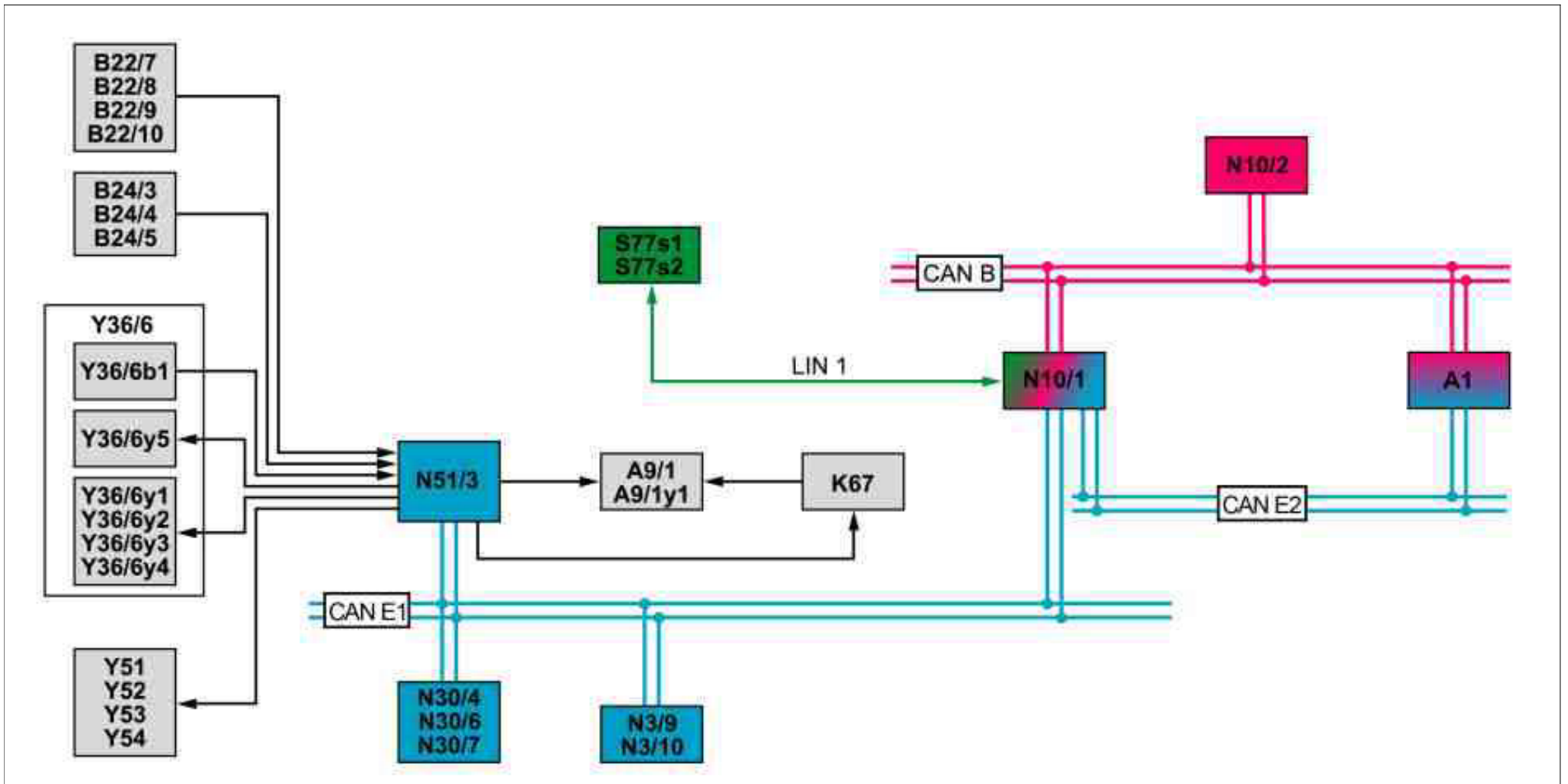

P32.22-2508-79

**Valid as of model year 2014**

A1	Instrument cluster	N3/10	ME-SFI [ME] control unit (with gasoline engine)	Y36/6y2	Right front level control valve
A9/1	AIRMATIC compressor	N10/1	Front SAM control unit with fuse and relay module	Y36/6y3	Left rear level control valve
A9/1y1	AIRMATIC pressure reduction valve	N10/2	Rear SAM control unit with fuse and relay module	Y36/6y4	Right rear level valve
B22/7	Left rear level sensor	N30/4	Electronic Stability Program control unit (except CODE 233 (DISTRONIC PLUS), except CODE 990 (AMG vehicles), except hybrid)	Y36/6y5	AIRMATIC central reservoir filling valve
B22/8	Left front level sensor	N30/6	Regenerative braking system control unit (for hybrid)	Y51	Left front axle damping valve unit
B22/9	Right front level sensor	N30/7	Premium Electronic Stability Program control unit (with CODE 233 (DISTRONIC PLUS) or with CODE 990 (AMG vehicles), except hybrid)	Y52	Right front axle damping valve unit
B22/10	Right rear level sensor	N51/3	AIRMATIC control unit	Y53	Left rear axle damping valve unit
B24/3	Left front body lateral acceleration sensor	S77s1	Electronic level control button	Y54	Right rear axle damping valve unit
B24/4	Right front body lateral acceleration sensor	S77s2	Comfort and Sport button	CAN B	Interior CAN
B24/5	Left rear body lateral acceleration sensor	Y36/6	AIRMATIC valve unit	CAN E1	Chassis CAN 1
K67	AIRMATIC relay	Y36/6b1	AIRMATIC pressure sensor	CAN E2	Chassis CAN 2
N3/9	CDI control unit (with diesel engine)	Y36/6y1	Left front level control valve	LIN 1	Instrument panel LIN