

**Document title** Remove/install belt pulley/vibration damper

**Document number** ar0330p1600el

Engine 157, 276, 278 in model 212, 218

Shown on engine 278

- 3 Crankshaft center bolt
- 4 Key
- 5 Crankshaft radial sealing ring
- 8 Belt pulley/vibration damper

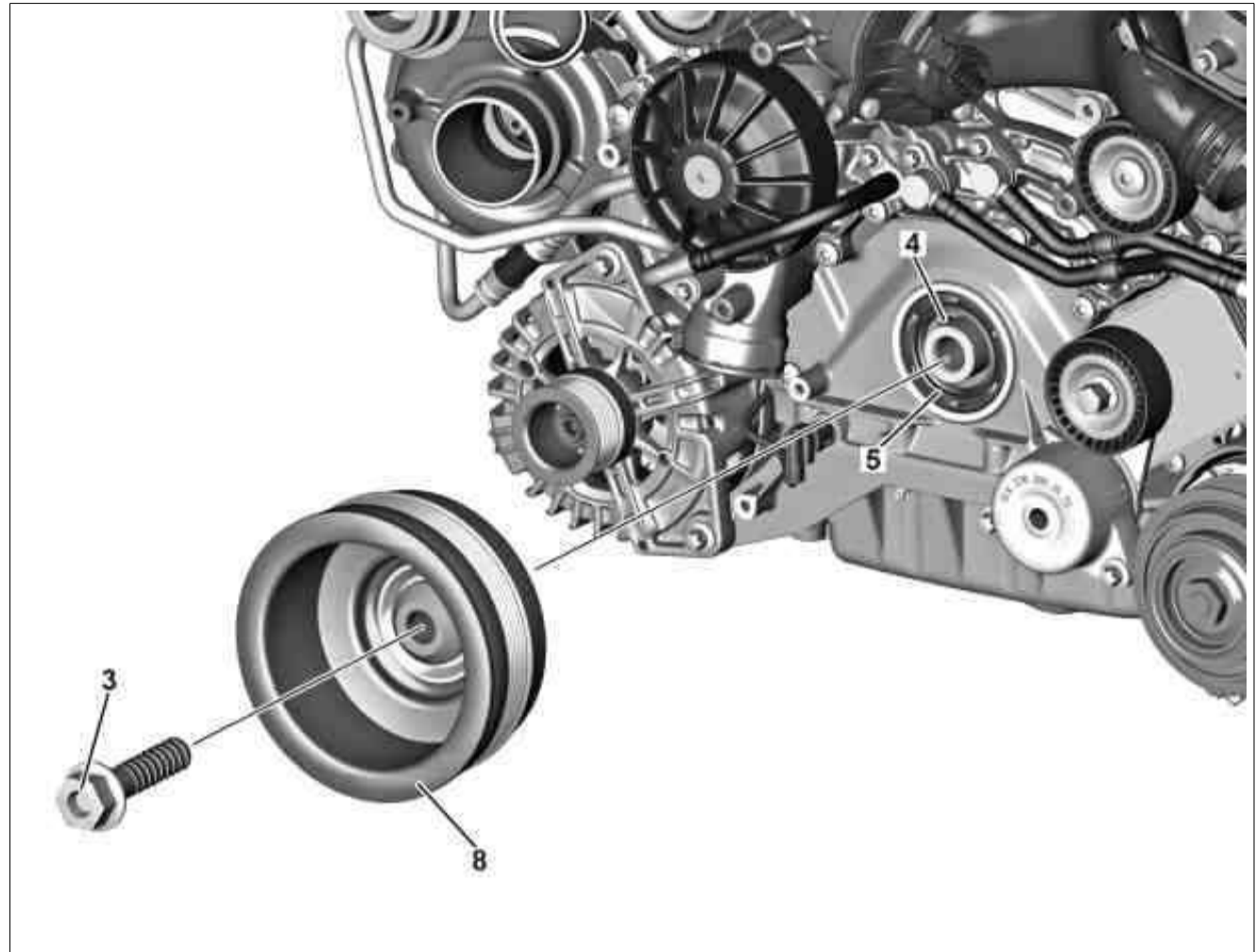

P03.30-2155-06





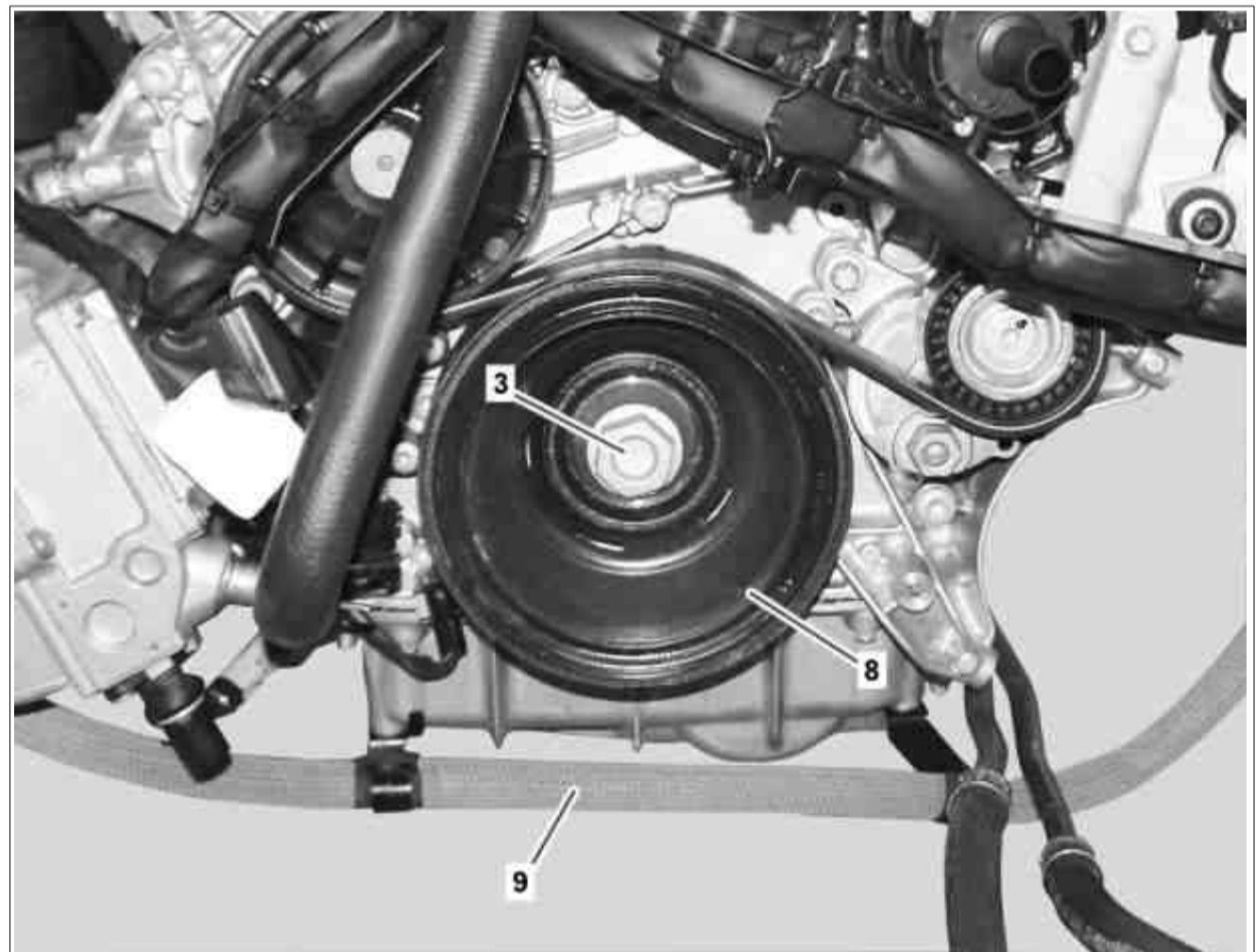



Shown on ENGINE 276.9 in MODELS 212.095/195

- 3 Crankshaft center bolt
- 8 Belt pulley/vibration damper
- 9 High-voltage line (ENGINE 276 in MODEL 212.095/195)



P03.30-2172-06

☒ ☒	Remove/install		
⚠ Warning	<b>Risk of injury</b> caused by fingers being jammed or pinched when removing, installing or aligning hoods, doors, trunk lid/rear-end door or sliding roof.	No parts of the body or limbs should be within the operating area when the components are moving.	AS00.00-Z-0011-01A
	<b>Risk of death</b> when working on component parts and systems with $U \geq 30$ V alternating voltage (AC) or $U \geq 60$ V direct voltage (DC)	Do not touch damaged or defective live component parts and lines or non-insulated electrical connections and lines.	AS00.00-Z-0035-01A
	General information on vehicles with high-voltage on-board electrical system and/or lithium-ion battery and/or gaseous-fuel drive system as well as personal protective equipment		AH00.00-Z-0300-01A
1	Switch off ignition		

2	Remove engine air intake duct upstream of air filter		
3.1	Remove engine cover	Engine 276.8 in model 212	
3.2	Remove front engine cover	Engine 157, 276.9, 278 in model 212, 218	
4	Release charge air cooler and place to one side with lines connected	Engine 276.8 in model 212	AR09.41-P-6819ELS
5	Remove poly-V belt	Engine 276.8 in model 212 ENGINE 276.9 in MODELS 212, 218 Engine 157, 278 in model 212, 218	AR13.20-P-0001ELS AR13.20-P-0001EL AR13.20-P-0001ELB
6	Install retaining lock for crankshaft/starter ring gear		AR03.30-P-5000EL
7	Cover high-voltage line (9) with a suitable means	Engine 276 in model 212.095/195  The high-voltage line (9) should be protected against excessive fouling and against getting damaged. If the high-voltage line (9) is damaged the high-voltage distributor must be replaced completely.	
8	Remove center bolt for crankshaft (3)	 <b>Installation:</b> Replace center bolt for crankshaft (3).  Center bolt, belt pulley to crankshaft	*BA03.30-P-1001-01M
9	Detach belt pulley/vibration damper (8) from crankshaft	 <b>Installation:</b> Place belt pulley/vibration damper (8) on crankshaft and rotate to ensure that the feather key (4) of crankshaft is engaged in the groove on the belt pulley/vibration damper (8).	
	<b>Check</b>		
10	Check contact surface of the crankshaft radial sealing ring (5) on the belt pulley/vibration damper (8) hub for scoring and galling	 Replace belt pulley/vibration damper (8) if necessary.	
11	Check front crankshaft radial sealing ring (5) for damage	 Replace front crankshaft radial seal (5) if necessary.	AR03.20-P-3000EL
12	Install in the reverse order		
	<b>Check</b>		
 Warning	<b>Risk of accident</b> from vehicle starting off by itself when engine running. <b>Risk of injury</b> (bruises and burns) resulting from working on the engine while it is being started or when it is running.	Secure vehicle to prevent it from starting off by itself. Wear closed and snug-fitting work clothes. Do not touch hot or rotating parts.	AS00.00-Z-0005-01A
13	Perform an engine test run and check engine for leak tightness		

 Flywheel, drive plate, vibration damper, starter ring gear

Number	Designation			Engine 157	Engine 276
BA03.30-P-1001-01M	Center bolt, belt pulley to crankshaft	Stage 1	Nm	200	200
		Stage 2	⌘°	180	180

 Flywheel, drive plate, vibration damper, starter ring gear

Number	Designation			Engine 278
BA03.30-P-1001-01M	Center bolt, belt pulley to crankshaft	Stage 1	Nm	200
		Stage 2	⌘°	180