

Dealer Ordering Guide

**PRELIMINARY.
DOCUMENT SUBJECT TO
CHANGE.**



Mercedes-Benz MY 17 E-Class Sedan (W213)

MY17 E-Class Sedan

Date of last revision: April 20, 2016

An important note about this Guide:

The information presented in this guide is based on the most current information available and is intended for internal use only. Mercedes-Benz reserves the right to make changes at any time, without notice, to colors, materials, equipment, special specifications and models. Pricing may not yet be finalized for some models or options.

Due to variances among monitors and printers the colors that appear on your screen and printouts may not be exact.

For illustrative purposes, some images may show vehicles with European Specification.

Revision History

| Date | Changes |
|----------|--|
| 03/10/16 | Initial release |
| 03/11/16 | Removed SiriusXM® Radio w/6 Month Service from stand-alone option |
| | Modified Premium P01 Package |
| 04/13/16 | 464 – 12.3” Widescreen Instrument Cluster now available as Stand-Alone Option (no longer SPC option) |
| | PAF – Acoustic – Comfort Package available as Stand-Alone Option (no longer SPC option) |
| | 322 – Sport Wheel Package now available |
| | 235 – PARKTRONIC w/Active Parking Assist renamed to Parking Pilot |
| | 501 – 360° Surround View Camera renamed to Surround View System |
| | P20 – Speed Limit Assist renamed to Speed Limit Pilot (NEW: automatic adoption of detected speed limits) |
| 04/15/16 | Updated <i>designo</i> Packages (P62 & P87) |
| 04/19/16 | Delayed availability: <i>designo</i> Packages (P62 & P87), Luxury Package (167) |
| 04/20/16 | P62 & P87 – <i>designo</i> Packages now available |
| | Updated Specifications (Trunk size) |
| | Modified Stand-Alone Options |

Table of Contents *(please click on the link to get to the page)*

- [What's new in MY17](#)
- [Models](#)
- [Standard Equipment](#)
- [Paints](#)
- [Upholsteries](#)
- [Trims](#)
- [Wheels](#)
- [Visual Equipment Differentiation](#)
 - [Headlights](#)
 - [Steering Wheels](#)
- [Option Packages](#)
- [Stand-Alone Options/Special Orders/Accessories](#)
- [Specifications](#)
- [Product Highlights](#)
- [Advantages over competition](#)
- [Gallery](#)

What's new: MY17 Overview

Exterior

- All-new exterior design

Interior

- All-new interior design

Standard Equipment

- 9G-TRONIC Automatic Transmission
- 12.3" high-resolution COMAND Display
- Active Brake Assist*
- Ambient Lighting (64 colors)
- ATTENTION ASSIST ®
- Auto Dimming Driver/ Rearview Mirrors
- COMAND Navigation
- Crosswind Assist
- DYNAMIC SELECT
- KEYLESS-START
- Power Adjustable Front Seats w/Lumbar Adjust. and 3-position Memory
- Power Folding Mirrors
- Power Tilt / Sliding Sunroof
- PRE-SAFE®
- PRE-SAFE® Sound
- Split Folding Rear Seats (40/20/40)
- Touch Control Buttons on newly designed steering wheel
- Touchpad w/ COMAND Controller



* Next Generation of COLLISION PREVENTION ASSIST PLUS

What's new: MY17 Overview

Optional Equipment

- New Premium Package Structure
- New Enhanced Safety Systems within Driver Assistance Package Plus
- DRIVE PILOT including Steering Pilot w/ Active Lane-Change Assist, Active Emergency Stop Assist, Distance Pilot DISTRONIC
- PRE-SAFE® Impulse Side
- Active Brake Assist w/Cross Traffic Function
- AIR BODY CONTROL Air Suspension
- Head-Up Display
- Rear Safety Package
- Warmth and Comfort Package

Paints

- Addition of Piedmont Green Metallic
- Addition of *designo* Selenite Grey Magno

Upholsteries

- New color options
- New *designo* upholstery packages

Trims

- Addition of Brown Ash Wood
- Addition of *designo* Black Piano Lacquer Flowing Lines Wood
- Addition of *designo* Magnolia Flowing Lines Wood

Wheels

- New 17", 18" and 19" wheel designs



What's new: Premium Package Structure w/ new optional equipment

MY16

Premium 1 Package

- Rearview camera
- Ventilated Front Seats
- SiriusXM® Satellite Radio w/ 6 Month Service
- Harman/Kardon® Sound System
- Heated Front Seats
- Powered Rear Window Sunshade
- Navigation Map Updates For 3 Years
- 7" COMAND w/ Navigation
- Power Folding Mirrors
- Split-Folding Rear Seats
- **MSRP \$4,180**

Std on MY17

MY17

Premium 1 Package

- Rearview camera
- Burmester® Premium Sound System
- Heated Front Seats
- Parking Pilot
- NFC Wireless Charging
- Keyless Go Comfort Pkg
- Blind Spot Assist
- **MSRP \$tbd**

New

Premium 2 Package

- Lighting Package
- Active Multicontour Seat Pkg
- Air Balance
- Power Rear Window Sunshade
- **MSRP \$tbd**

Premium 3 Package

- Surround View System
- Driver Assistance Pkg Plus
- Head-Up Display
- **MSRP \$tbd**



What's new: Sport Wheel Package

\$tbd

Optional on Sport only



The Sport Wheel Package includes:

- Perforated front brake discs & front brake calipers w/ "MB" lettering (U29)
- Black headliner (51U)
- Wheel choice of:
 - 18" AMG 5-spoke light-alloy wheels (RQR)
 - 19" AMG 5-twin-spoke light-alloy wheels (RTK)* (+\$500)



RQR



RTK*

*as seen on image



What's new: PRE-SAFE® Sound

Standard on all E-Class

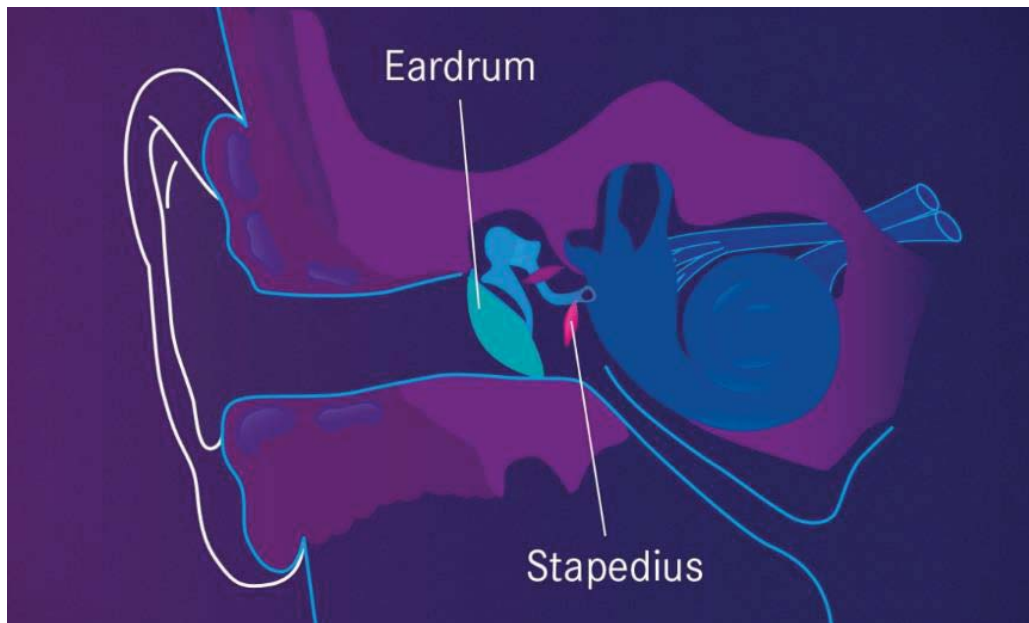

Part of PRE-SAFE, PRE-SAFE Sound is an acoustic occupant preconditioning system which can reduce the effects of the noise from an accident on the occupants hearing.

- When the PRE-SAFE system recognizes a certain dangerous situation, the onboard sound system plays a brief rushing sound, also known as 'Pink Noise', to precondition the hearing
- The natural reflex mechanism of the stapedius muscle enables the inner ear to rapidly prepare for the accident-induced high pressure sound
- Up to 40% reduction of noise exposure impact



What's new: 531 - COMAND Navigation (NTG 5.5)

Standard on all E-Class



The COMAND system at a glance:

- High-resolution 12.3-inch display
- Fast HDD navigation with 3D maps
- WiFi hotspot provides 4G-LTE internet connection
- Smartphone Integration via Apple CarPlay® & Android Auto
- *Bluetooth* hands-free and audio streaming
- Voice-operated control system
- Car-to-X Communication
- NFC pairing to headunit (NFC wireless charging is part of Premium P01 Package)



What's new: Car-to-X Communication

Standard on all E-Class

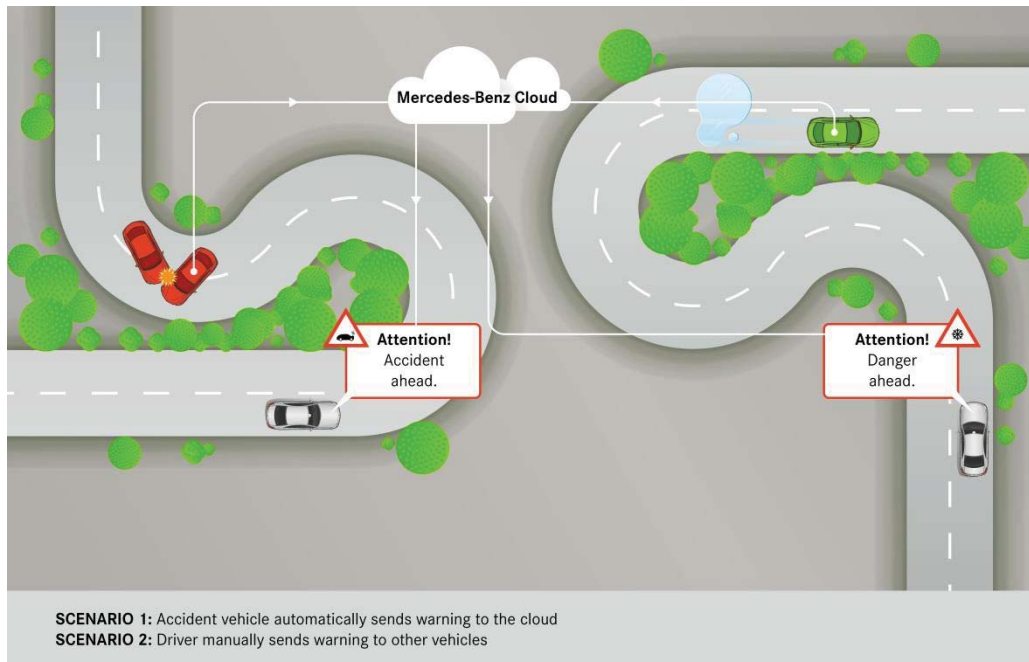

- Exchange of information with other vehicles in the surrounding area (now only from new E-Class to new E-Class) for:
 - Break-downs
 - Accidents
 - Hazardous weather (ice, fog, rain, snow, etc.)
- Driver can also send a warning manually
- Warning according to situation:
 - Icon on navigation display
 - Instrument cluster
 - Voice output



What's new: Touch Control Buttons

Standard on all E-Class



The new E-Class introduces the all new concept of Touch Control Buttons on the 3-spoke steering wheel to operate the instrument cluster and the headunit by horizontal and vertical swiping movements of the finger. The main focus is to keep the customer's hands on the steering wheel and eyes on the road.

- The instrument cluster is operated by the left Touch Control Button
- The head unit (incl. navigation) is operated by the right Touch Control Button



What's new: 448 – Touchpad

Standard on all E-Class



The functions of COMAND navigation can be controlled intuitively via the innovative touchpad, using single or multi-finger gestures (multi touch).

- Touchpad approx. 2.56 x 1.77 inches in size
- Additional full-fledged input option supplementing the COMAND Controller, touch control buttons on the steering wheel and voice control
- Recognizes single and multi-finger gestures (multi-touch), swiping movements and zoom gestures achieved by spreading the fingers or pinching them together
- Innovative handwriting recognition feature: Users are able to input letters, special characters and numbers in their normal handwriting, in any language available in the headunit
- 3 buttons located behind the touchpad allow fast and direct operation of important functions
- Clear haptic feedback when using the touchpad or keys



What's new: 897 - NFC Wireless Charging

Optional on all E-Class, included in Premium Package P01



- Pairing to the headunit via NFC
- Wireless charging of smartphones that support the Qi standard
 - For charging place the smartphone in the front storage compartment in the center console
 - Storage compartment designed for mobile phones with a screen diagonal of up to 6 inches



What's new: 463 – Head-Up Display

Optional on all E-Class, included in Premium Package P03



The Head-Up Display at a glance:

- Key driver information at a glance (e.g. navigation tips, incoming calls, speed, settings for cruise control, assistance system messages) without the driver having to take their eyes off the road
- Projection of a virtual image measuring approx. 8.3 x 2.8 inches into the driver's field of vision, which appears to float around 78.7 inches in front
- Presentation of information in high-resolution and in color, making it clearly legible even on sunny days and at night
- Height position of the image, brightness and displayed content can be changed individually via a menu in the instrument cluster



What's new: B59 - DYNAMIC SELECT

Standard on all E-Class



At a touch of the DYNAMIC SELECT feature, drivers can choose between comfortable, sporty, particularly sporty and efficient driving styles, or their own individually defined style. Parameters such as the engine, transmission and steering characteristics are adjusted according to the selected drive mode.

Choice of up to 5 different driving programs:

1. Comfort “C” standard setting: well-balanced and fuel-efficient
2. Eco “E” mode: for keeping fuel consumption as low as possible
3. Sport “S” mode: added agility and dynamism due to direct steering characteristics sporty, taut suspension tuning, spontaneous throttle response and modified shift points
4. Sport+ “S+” mode: even sportier performance, the suspension (in conjunction with AIR BODY CONTROL air suspension) and drive system have an even more dynamic setup
5. Individual mode: individual parameters can be varied as required, using the Controller and the configuration menu in the head unit



What's new: 421 – 9G-TRONIC Automatic Transmission

Standard on all E-Class

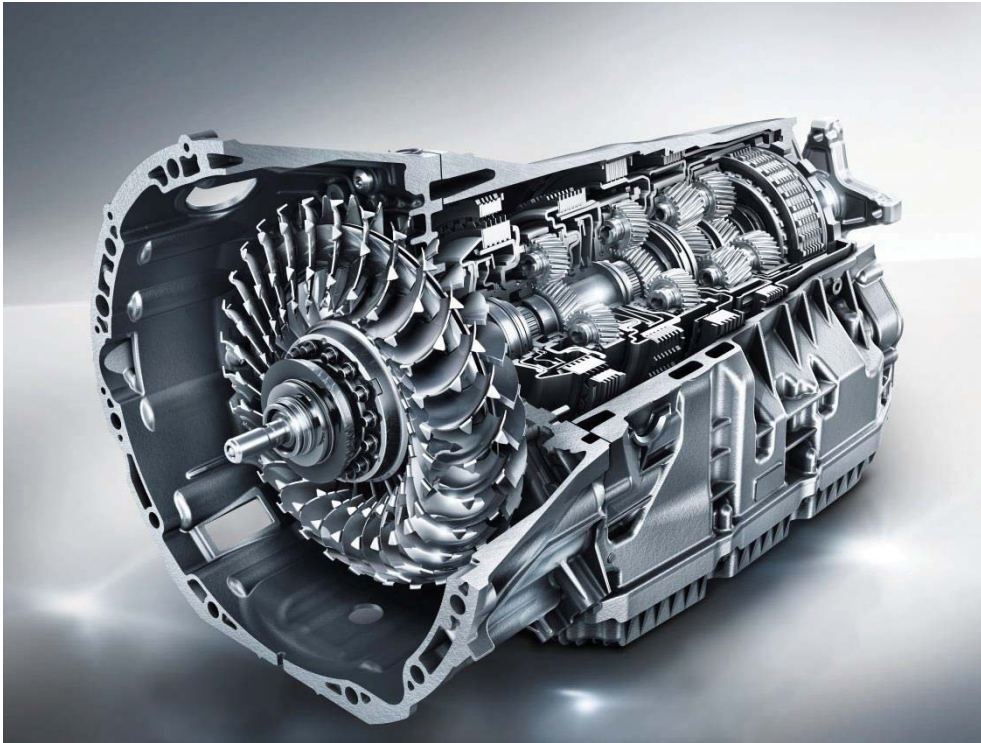

9G-TRONIC – faster, smoother, more efficient

Featuring nine forward gears, this automatic transmission takes efficiency, comfort and dynamism to a completely new level. It is the new generation 9-speed automatic transmission with hydrodynamic torque converter in the premium segment. The larger ratio range allows a reduction in engine speed. Performance remains excellent while ride comfort is enhanced and noise levels are reduced. The reduced intervals between the gears lead to faster gear changes and enhanced spontaneity and agility. At the same time, the 9G-TRONIC impresses with smooth, barely perceptible gear shifting like that of a continuously variable transmission. As the 9G-TRONIC is able to skip individual gears, multiple downshifts are possible for fast and powerful sprints.



What's new: Exterior Comparison E-Class MY16 (W212) vs New E-Class MY17 (W213) - Sport

E-Class MY 2016 Exterior



New E-Class MY 2017 Exterior



What's new: Exterior Comparison E-Class MY16 (W212) vs New E-Class MY17 (W213) - Sport

E-Class MY 2016 Exterior



New E-Class MY 2017 Exterior

Sporty, elegant design with coupe-like elements & broad shouldered tail end

New rear tail light design with "stardust" effect



Continuous shoulder line for a powerful, stretched body

New rear bumper design



What's new: Exterior Comparison E-Class MY16 (W212) vs New E-Class MY17 (W213) - Sport

E-Class MY 2016 Exterior



New E-Class MY 2017 Exterior

Aluminum & ultra-high-strength steel resulting reduced weight and optimized aerodynamics

High, curved beltline, low side windows

Standard 18" wheels (European Model Shown)

Increased vehicle length by 1.7" & longer wheelbase by 2.6"

Reduced rear overhangs



What's new: Exterior Comparison E-Class MY16 (W212) vs New E-Class MY17 (W213) - Luxury

E-Class MY 2016 Exterior



New E-Class MY 2017 Exterior



Standard 18" wheels

Redesigned front bumper w/ chrome trim elements



What's new: Exterior Comparison E-Class MY16 (W212) vs New E-Class MY17 (W213) - Luxury

E-Class MY 2016 Exterior



New E-Class MY 2017 Exterior



Single-exhaust system with two tailpipe trim elements integrated into the bumper

Suspension w/ automatic dampening system



Specifications*

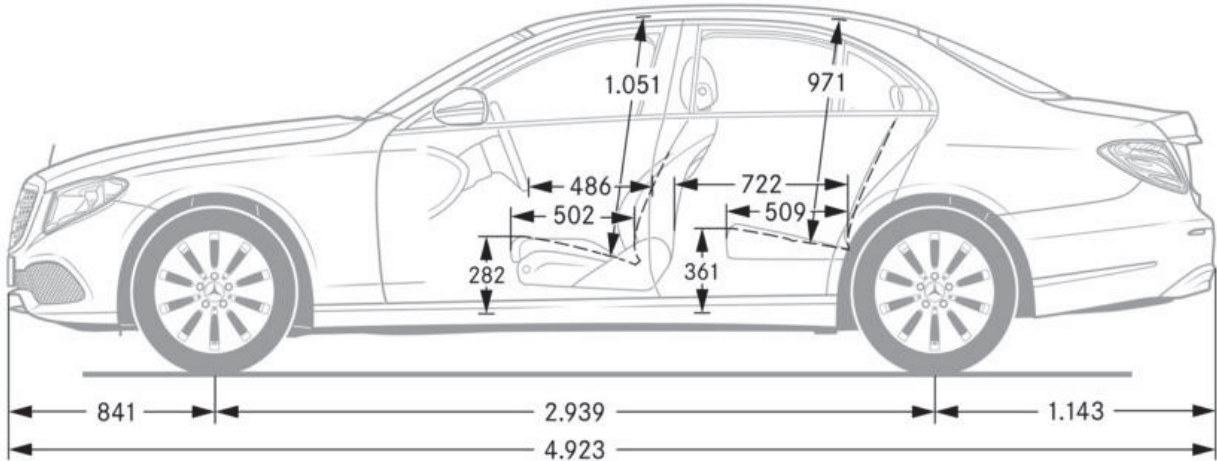
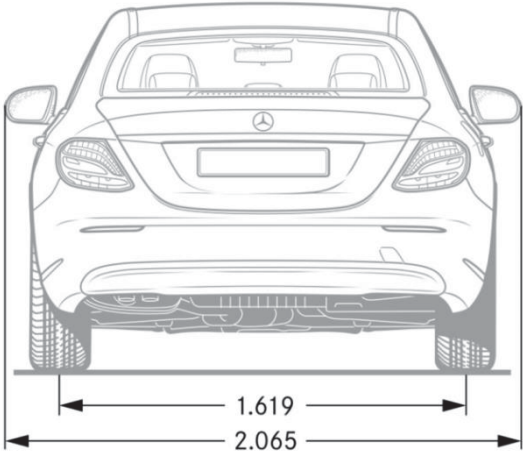
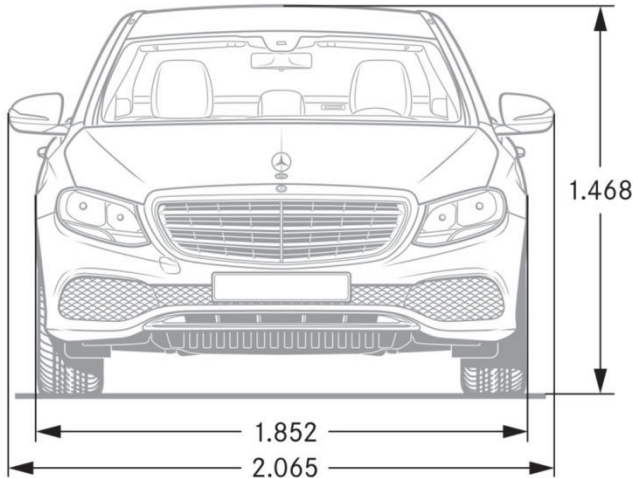

MY17 E-Class Sedan

*Values shown in meter / millimeters



What's new: Interior Comparison E-Class MY16 (W212) vs New E-Class MY17 (W213)

E-Class MY 2016 Interior



New E-Class MY 2017 Interior*

Ambient Lighting w/ 64 colors

New designed 3-spoke steering wheel

New 12.3" COMAND Screen

Dash w/ MB-Tex & top stitching
Luxury only



Touch control buttons

New designed center console w/touchpad

DYNAMIC SELECT



*Sport shown

Models

| | Displacement | Power | Torque | MSRP | Launch |
|----------------------|------------------------|----------------|--------------------------|-------|----------------|
| E300 (213.048) | 2.0L Inline-4 Turbo | 241 @ 5,500 | 273 @ 1,300- 4,000 | \$tbd | Summer 2016 |
| E300 4M (213.049) | 2.0L Inline-4 Turbo | 241 @ 5,500 | 273 @ 1,300- 4,000 | \$tbd | Summer 2016 |



Standard Equipment Highlights

Performance/Handling

- 9G-TRONIC Automatic Transmission
- 2.0L Inline-4 Turbo Engine (241 hp, 273 lb-ft)
- DYNAMIC SELECT driving programs

Comfort/Convenience

- Ambient Lighting (64 colors)
- Auto-Dimming Driver-Side and Rearview Mirrors
- Bluetooth® Connectivity
- COMAND Navigation System
- Garage Door Opener
- KEYLESS-START
- LED Headlamps
- Power Adjustable Front Seats w/ 3-Position Memory
- Power Folding Mirrors
- Power Tilt/Sliding Sunroof
- Smartphone Integration with Apple CarPlay® & Android Auto
- Split Folding Rear Seats (40/20/40)
- Touch Control Buttons on steering wheel
- Touchpad w/Controller
- 12.3" High-resolution Display
- 4-way Lumbar Support
- 5 Years of mbrace® Connect Service

Safety/Security

- Active Brake Assist
- ATTENTION ASSIST®
- Crosswind Assist
- LED Lights
- PRE-SAFE®
- PRE-SAFE® Sound
- Tire Pressure Monitoring System

Paints

Non-metallic Paints

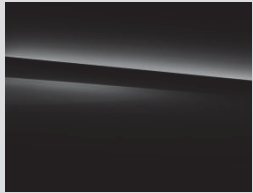

040
Black



149
Polar White

Metallic Paints¹

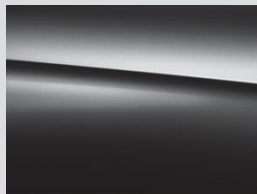

197
Obsidian Black



775
Iridium Silver



796
Dakota Brown



890
Lunar Blue

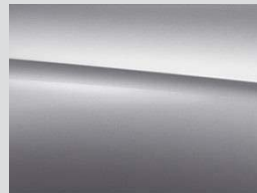

988
Diamond Silver



992
Selenite Grey



997
Piedmont Green

designo Metallic Paints^{**}

Metallic paint with high-quality effect pigments and exclusive color shades



297
Selenite Grey Magno²

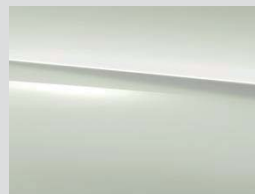

799
Diamond White³



996
Cardinal Red⁴

¹Additional charges: \$tbd

²Additional charges: \$tbd

³Additional charges: \$tbd

⁴Additional charges: \$tbd



Upholsteries

Preliminary pricing
subject to change

Standard – Sport

MB-
Tex



121 Black
Crystal Grey Headliner



124 Nut Brown/Black
Black Headliner
*(image does not reflect
black headliner)*



125 Macchiato Beige / Black
Beige Headliner

Optional - Sport

Leather



201 Black¹
Crystal Grey Headliner



214 Nut Brown/Black¹
Black Headliner
*(image does not reflect
black headliner)*



215 Macchiato Beige/Black¹
Beige Headliner

¹Additional charge on Sport: \$tbd

51U – Black Headliner
55U – Beige Headliner
58U – Crystal Grey Headliner



Upholsteries

Preliminary pricing
subject to change

Standard - Luxury

MB-
Tex



131 Black
Crystal Grey Headliner



144 Nut Brown/Esspresso
Beige Headliner



145 Macchiato Beige /
Espresso
Beige Headliner

Optional - Luxury

Nappa
Leather



801 Black¹
Crystal Grey Headliner



814 Nut Brown /
Espresso Brown¹
Beige Headliner



815 Macchiato Beige/
Espresso Brown¹
Beige Headliner

¹Additional charge on Luxury: \$tbd

- 51U - Black Headliner
- 55U - Beige Headliner
- 58U - Crystal Grey Headliner



Upholsteries

Optional



designo
Exclusive Nappa Leather



961 *designo*
Black / Titanium Grey Pearl¹
Black DINAMICA Headliner
\$td



975 *designo*
Macchiato Beige / Saddle Brown¹
Macchiato Beige DINAMICA Headliner
\$td

¹Requires P02 / P03 Premium Package



Trims

H09 – Natural Grain Brown Ash Wood



Standard on Sport
N/C on Luxury

736 – Natural Grain Black Ash Wood

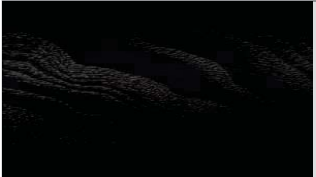

Optional on all models
N/C

H06– Brown Ash Wood

new



Optional on all models
N/C

731 – Burl Walnut Wood



Standard on Luxury
N/C on Sport

H16 – *designo* Black Piano Lacquer Flowing Lines Wood

new



Optional on all models
\$tbd

H26 – *designo* Magnolia Flowing Lines Wood

new



Optional on all models
\$tbd

Trims

739 – Aluminum (SPC)



Optional on all models
N/C

Wheels

Standard

Optional

E300/ 4M
Sport model



new

R31 - 5-spoke
R02 & R66
18"



new

RQR -AMG 5-spoke
R02 & R66
18"
(only i.c.w. Sport wheel pkg)



new

RTK - AMG 5-twin-spoke
R02 & R66
19"
(only i.c.w. Sport wheel pkg)

E300/ 4M
Luxury model



new

R54 - 5-twin-spoke
R02 & R66
18"



new

R07 - 5-twin-spoke
R02 & R66
17" (no-cost option)



Visual Equipment Differentiation

Headlights

LED Headlamps (Standard)



- All functions feature LED technology
- Excellent illumination of the road
- Integrated LED daytime running lamps with fiber optics
- Projector LED low-beam and reflective LED high-beam technology
- New LED tail lamps featuring 72 LEDs
- Low energy consumption
- Color of emitted light more similar to that of daylight
- Much longer bulb life

LED Intelligent Headlamps (Included in P02 Premium Package)



All functions of the standard LED headlamps plus:

- Automatic high-beam control by Adaptive Highbeam Assist
- Automatic adaptation of headlamps to weather, lighting and driving conditions for ideal visibility in every situation
- Automatically activated cornering lights
- Active light function for significantly better illumination in bends
- Distinctive look during day and night



Preliminary pricing
subject to change

Visual Equipment Differentiation

Steering Wheels

L3C - Standard – 3-spoke Multifunction Steering Wheel



- Standard on all models
- The all new 3-spoke steering wheel in nappa leather comes with unique Touch-Control buttons in the control panels on the left and right. The steering wheel is embossed in the center grip area.

L3D – Wood/leather Steering Wheel (requires 731)

\$tbd



- Optional on all models
- The combination of high-quality leather in the grip area and fine wood inserts at the top and bottom make this steering wheel a visual and tactical highlight.
- Only available with Burl Walnut Wood (731). N/A with heated steering wheel (443).

443 – Heated Steering Wheel

\$tbd



- Optional on all models
- On cold days, heating of the steering wheel rim very rapidly ensures cozy temperatures of the grip area and thus also warm hands. The switch for turning the heating on and off is positioned right next to the steering wheel.
- N/A with Wood/leather steering wheel (L3D).

Option Packages

Preliminary pricing
subject to change

P01 – Premium 1 Package

\$tbd

- 218 – Rearview camera
- 235 – Parking Pilot
- 810 – Burmester® Premium Sound System
- 897 – NFC Wireless Charging
- P17 – KEYLESS-GO Comfort Pkg code
 - 871 – Hands-Free-Access
 - 881 – Electric Trunk Closer
 - 889 – KEYLESS-GO
- 234 – Blind Spot Assist
- 873 – Heated Front Seats

P02 – Premium 2 Package

\$tbd

- P35 – Lighting Package code
 - 640 – LED Intelligent Headlamps
 - 608 – Adaptive Highbeam Assist
- 432 – Active Multicontour Seat Package (Driver/Passenger) code
 - 902 – Heated Front Seats Plus
 - 436 – Comfort Front Head Restraint
- P21 – Air Balance Package
- 540 – Power Rear Window Sunshade

P03 – Premium 3 Package

\$tbd

- P44 – Parking Assist Package code
 - 501 – Surround View System
- P20 – Driver Assistance Package Plus
- 463 – Head-Up Display

Option Packages (continued)

Preliminary pricing
subject to change

167 - Luxury Package

\$tbd

Delayed availability

- 485 - Suspension with selective damping system
- Luxury 3-Lamella Chrome Grille with 'standing star'
- U09 - Dash with MB-TeX and top-stitching
- Wheel choice of:
 - R54 - 18" 5-twin-spoke Wheel , All-Season, Run-Flats
 - R07 - 17" 5-twin-spoke Wheel (no-cost) , All-Season, Run-Flats

322 - Sport wheel package (only i.c.w Sport)

\$tbd

- U29 - Perforated front brake discs & front brake calipers w/ 'MB' lettering
- 51U - Black headliner
- Wheel choice of:
 - RQR - 18" AMG Wheel, All-Season, Run-Flats
 - RTK - 19" AMG Wheel, All-Season, Run-Flats (+\$500)

445 - Warmth and Comfort Package

\$tbd

- 902 - Heated Front Seats Plus
- 906 - Heated Armrest and Upper Door Trim
- 443 - Heated Steering Wheel
- 431 - Shift Paddles

Option Packages (continued)

Preliminary pricing
subject to change



P62 - *designo* Titanium Grey Pearl / Black Nappa Leather \$tbd

- U38 - Dashboard in Nappa Leather
- U04 - *designo* floor mats
- 61U - *designo* Black DINAMICA Headliner¹
- P62 - *designo* Package code

Available with all trim choices, requires 961 upholstery code

¹Requires P02/ P03 Premium Package



P87 - *designo* Macchiato Beige / Saddle Brown Nappa Leather \$tbd

- U38 - Dashboard in Nappa Leather
- U04 - *designo* floor mats
- 65U - *designo* Macchiato Beige DINAMICA Headliner¹
- P87 - *designo* Package code

Available with all trim choices, requires 975 upholstery code

¹Requires P02/ P03 Premium Package



Stand-Alone Options/Special Orders/ Accessories

Preliminary pricing
subject to change

| Stand-Alone Options | | |
|---------------------|--|-------|
| 218+235 | Rearview camera + Parking Pilot | \$tbd |
| 2xx | Leather upholstery <i>Available w/ Sport only</i> | \$tbd |
| 325 | Rear Safety Package <i>Incl. rear safety package code (P36), rear-side airbags (293) & rear seatbelt airbags (306)</i> | \$tbd |
| 401 | Heated and Ventilated Front Seats <i>Requires leather (2xx)/ nappa leather (8xx) upholstery Not available with heated front seats (873)</i> | \$tbd |
| 413 | Panorama Roof <i>Standard power tilt/ sliding sunroof (414)</i> | \$tbd |
| 443 | Heated steering wheel | \$tbd |
| 464 | 12.3" Widescreen Instrument Cluster <i>Requires P03 Package</i> | \$tbd |
| 489 | AIR BODY CONTROL air suspension | \$tbd |
| 8xx | Nappa leather upholstery <i>Available w/ Luxury (167) only</i> | \$tbd |
| 873 | Heated front seats <i>Not available with 401, P02/P03 Package or 445 Package</i> | \$tbd |
| L3D | Wood/leather steering wheel <i>Requires burl walnut wood (731). N/A with 445 Package or heated steering wheel (443)</i> | \$tbd |
| U80 | 115V AC power outlet | \$tbd |
| PAF | Acoustic - Comfort Package <i>Includes Code 596</i> | \$tbd |



Stand-Alone Options/Special Orders/ Accessories

Preliminary pricing
subject to change

Special Order Options (additional charge of \$250)

| | | |
|-----|--|-------|
| 313 | Rear Door Roller Blinds <i>Includes Code P09 Package</i> | \$tbd |
| 872 | Heated Rear Seats <i>Requires one of the following heated front seat options: 873, P01, P02, P03 or 401 and leather (2xx) or nappa leather (8xx) upholstery</i> | \$tbd |

MB Accessories Program

| | | |
|-----|--|-------|
| 00A | Illuminated Star <i>Not available w/ P03 Premium Package</i> | \$tbd |
| 068 | Wheel Locks | \$tbd |
| 070 | Chrome Door Handle Inserts (Set of 4) | \$tbd |
| 104 | Rear Spoiler | \$tbd |
| 129 | Accessory Styling Package (Rear & Roof Spoiler) <i>Not available w/ 104</i> | \$tbd |
| 137 | Comfort Box | \$tbd |

Specifications

| | E300 | E300 4MATIC |
|----------------------------------|---------------------|---------------------|
| Engine Configuration | 2.0L Inline-4 Turbo | 2.0L Inline-4 Turbo |
| Power (hp) | 241 | 241 |
| Torque (lb-ft) | 273 | 273 |
| Displacement (cc) | 1,991 | 1,991 |
| Acceleration 0-60mph (sec) | 6.2 sec (est.) | tbd (est) |
| Fuel Economy (Cty/Hwy) | tbd | tbd |
| Top Speed (mph) | 130 | 130 |
| Fuel Requirement (Octane) | 91 | 91 |
| # Valves per cylinder | 4 | 4 |
| Compression | 9.8:1 | 9.8:1 |
| Transmission | 9G-TRONIC Auto. | 9G-TRONIC Auto. |
| Transmission Speeds | 9 | 9 |
| Drive Configuration | Rear-Wheel Drive | All-Wheel Drive |
| Standard Front Wheel (Sport) | 8 J x 18 | 8 J x 18 |
| Standard Rear Wheel (Sport) | 8 J x 18 | 8 J x 18 |
| Standard Front Tire Size (Sport) | 245/45 R18 | 245/45 R18 |
| Standard Rear Tire Size (Sport) | 245/45 R18 | 245/45 R18 |
| Standard Tire Type | All Season | All Season |
| Fuel Tank Size (gallons) | 17.4 | 17.4 |
| Trunk Size (cubic feet) | 13.1 | 13.1 |
| Curb Weight (lbs) | tba | tba |
| Vehicle Length (in.) | 193.82 | 193.82 |
| Vehicle Width (in.) | 81.30 | 81.30 |
| Vehicle Height (in.) | 57.80 | 57.80 |
| Wheelbase | 115.7 | 115.7 |
| Track Width Front/Rear (in.) | 33.11/45.00 | 33.11/45.00 |



Product Highlights: Active Brake Assist *(Formerly CPA PLUS)*

Standard on all models

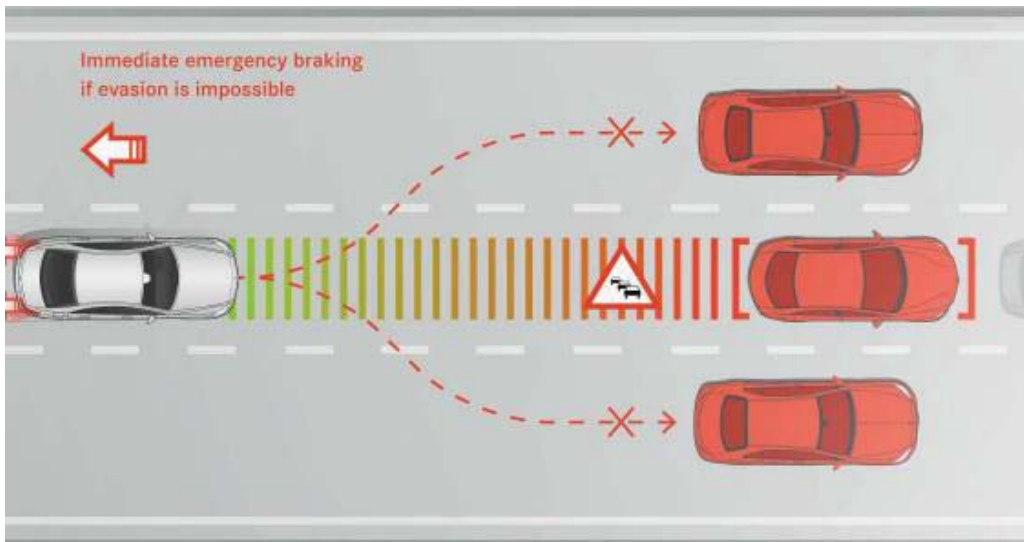

- Radar-based driving assistance system that can help prevent accidents with vehicles ahead and with crossing pedestrians or mitigate the consequences of accidents
- Combination of proximity warning, collision warning, on-demand braking assistance and autonomous braking function
- Additional audible warning if the distance diminishes rapidly
- If the driver initiates emergency braking – if necessary – increase in braking pressure by the on-demand braking assistance
- Initiation of autonomous braking if the driver fails to react
- Visual and audible warning plus almost simultaneous emergency braking if an impending collision with a **crossing pedestrian** is detected



Product Highlights: Crosswind Assist

Standard on all models

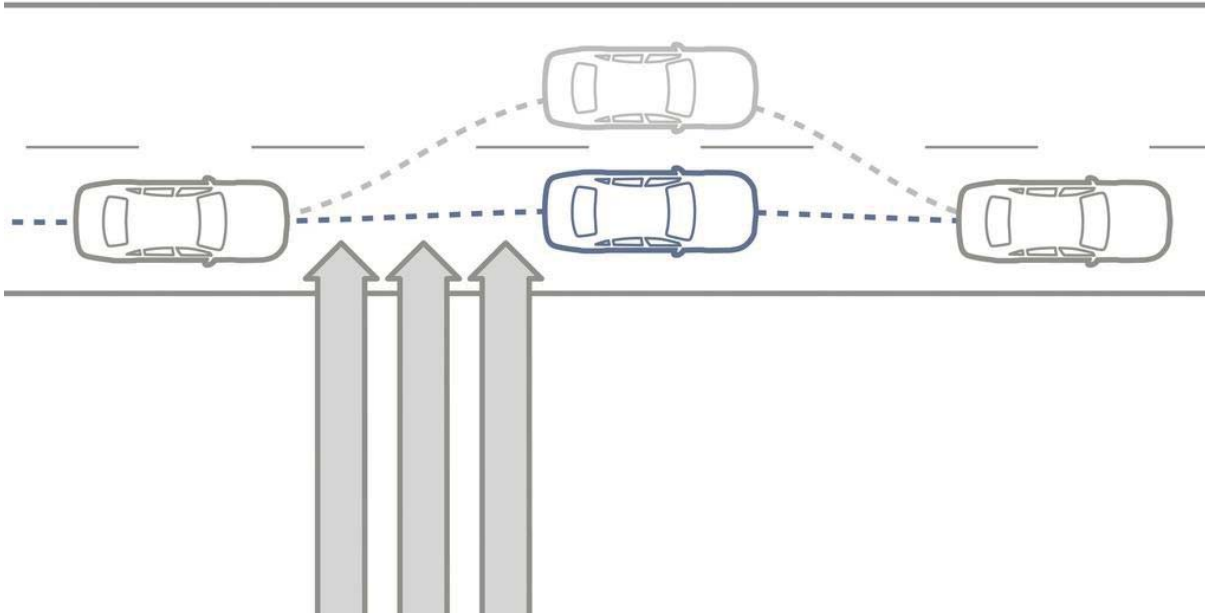

- Traditionally, strong gusts of wind may lead to sudden lateral drift of the vehicle
- Crosswind Assist aids the driver by reducing the vehicle's lateral drift substantially in windy driving conditions
- Crosswind Assist is integrated into the ESP® sensor system and enables the timely detection of gusts of crosswind
- Automatic brake intervention on the wheels on the side of the vehicle facing the wind results in a motion which counteracts the crosswind
- Crosswind Assist substantially enhances the driver's sense of control, stability and safety



Product Highlights: AIR BODY CONTROL

Optional on all models



- Multi-chamber air suspension combined with continuously adjustable damping to improve ride comfort and driving dynamics
- Vehicle characteristics can be varied from comfortable through to sporty using DYNAMIC SELECT switch
- "Comfort" and "Sport" settings for a more comfortable or stiffer, sportier setup
- Constant vehicle level irrespective of load thanks to pneumatic all-round self-levelling suspension
- Suspension level can be raised for poor surfaces and is automatically lowered at high speeds, helping to reduce aerodynamic drag and further improve handling stability
- It is possible to lower the vehicle level by 1.6 inches to make it easier to load the luggage compartment.

Product Highlights: Burmester® Premium Sound System

Optional on all models – Included in P01 Premium Package



- 13 high-performance speakers precisely configured for the vehicle interior to ensure well-balanced and very dynamic music reproduction
- 9-channel DSP amplifier with a total output of 590 watts (7 x 50 W and 2 x 120 W) for maximum sound quality with very high volume reserves
- Frontbass technology with woofers integrated into the body shell for vibrant bass reproduction
- Combination of digital and analogue filter elements for the unique Burmester "feel-good sound"
- Sound optimization for the front and rear seats
- Noise compensation (VNC)
- Sound preset: surround function to generate virtual all-round sound
- Support for popular multi-channel formats such as Dolby Digital 5.1/DTS for example, for true surround sound

Product Highlights: Intelligent Drive - Overview

Optional on all models – Included in P03 Premium Package



“Intelligent Drive” is a gateway to more autonomous & accident-free driving which increases safety for all drivers on the road. The following lists all features that are available with the all new E-Class:

- **DRIVE PILOT** (includes Steering Pilot w/ Active Lane Change Assist, Active Emergency Stop Assist and Distance Pilot DISTRONIC)
- **Active Brake Assist with cross-traffic function**
- **Evasive Steering Assist**
- PRE-SAFE® PLUS
- **PRE-SAFE® Impulse Side**
- Active Lane Keeping Assist
- Active Blind Spot Assist
- Speed Limit Pilot (displays speed limit and automatic adoption of detected speed limits)

Product Highlights:

Intelligent Drive – DRIVE PILOT

Optional on all models – Included in P03 Premium Package

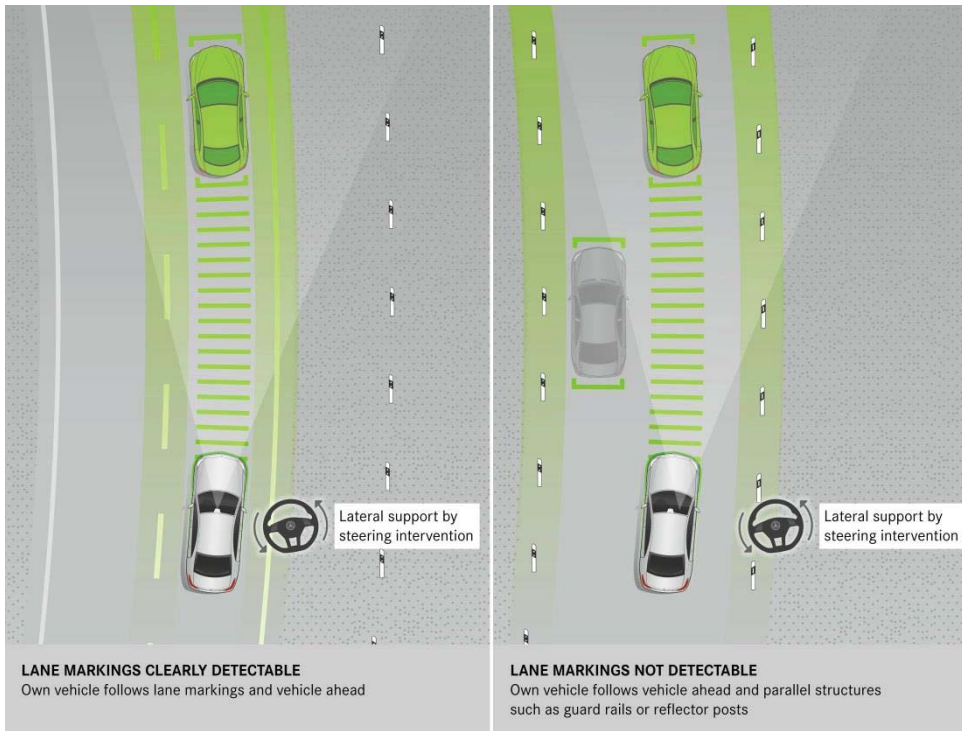

- Steering Pilot generates steering torque which helps the driver to keep the vehicle in the center of its lane (straight roads and slight bends), taking its guidance from vehicles ahead and road lane markings
- Active Lane Change Assist helps the driver with changing lanes by means of steering torque, the moment the driver initiates the change by activating the indicator and the system does not detect another vehicle in the adjacent lane
- Extended tolerance for the Hands-Off Warning of the Steering Pilot with intelligent Hands-On Detection
- Active Emergency Stop Assist brakes the vehicle to a controlled stop if the system detects that the driver is permanently distracted or is no longer able to operate the vehicle
- Distance Pilot DISTRONIC maintains the selected distance from the vehicle in front, and works in the speed range from 0 – 130 mph, also reacting to stationary vehicles at low speeds

Product Highlights: Intelligent Drive – Active Brake Assist with cross-traffic function

Optional on all models – Included in P03 Premium Package



- The system is able to reduce the risk of rear-end collisions and accidents at road junctions
- Monitoring of traffic situation ahead of the vehicle by means of radar sensors and stereo cameras
- Vehicles travelling ahead are detected up to a speed of 130 mph
- Crossing traffic and bicyclists are registered up to a speed of 45 mph, as well as pedestrians who are stationary or moving slowly in the path of the vehicle
- When danger of a collision is detected, the system gives a visual and audible warning
- If the driver firmly applies the brakes, the system calculates the brake pressure that would be needed to prevent a collision
- If a collision cannot be prevented, the impact speed is reduced as much as possible by emergency braking

Product Highlights: Intelligent Drive – Evasive Steering Assist

Optional on all models – Included in P03 Premium Package

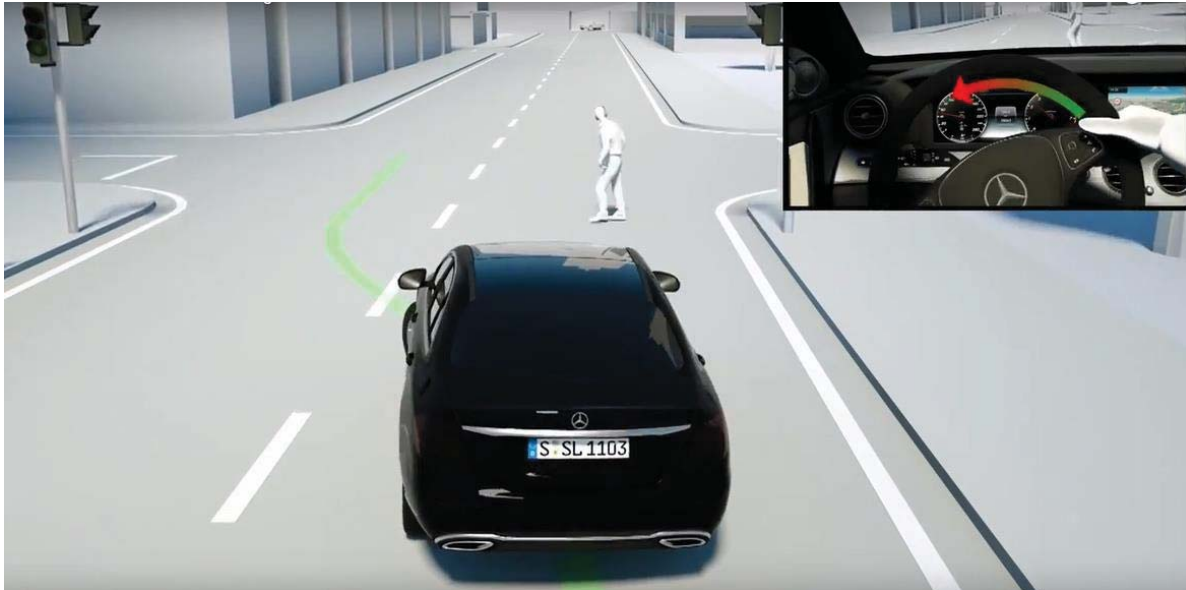

- When the driver deliberately or instinctively performs an evasive maneuver in a dangerous situation (pedestrian crossing the street), Evasive Steering Assist provides assistance by adding precisely calculated steering torque to support the movement of the steering wheel
- This helps the driver to avoid a pedestrian in a controlled manner while subsequently facilitating the movement of the vehicle to allow the situation be negotiated safely

Product Highlights:

Intelligent Drive – PRE-SAFE® Impulse Side

Optional on all models – Included in P03 Premium Package

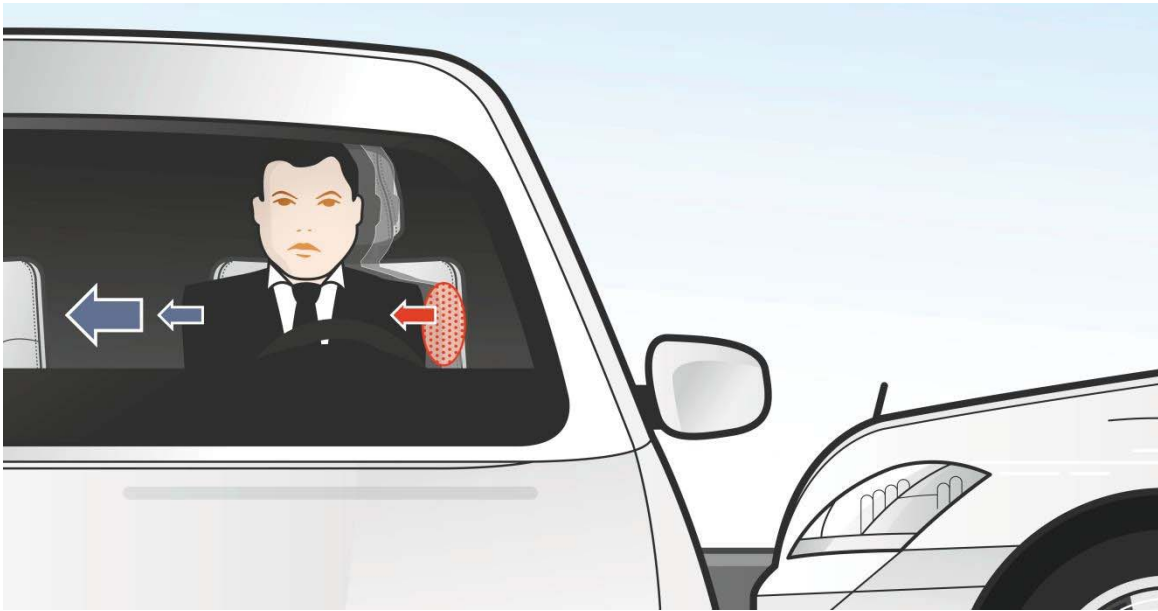

- PRE-SAFE® Impulse Side initiates preventative protective measures against an impending side impact, supplementing the measures taken by PRE-SAFE® and PRE-SAFE® PLUS
- In the event of a side impact, PRE-SAFE® Impulse Side can have a positive effect by increasing the distance between the occupant and the door, and at the same time reducing the relative speeds between the side structure and the occupant's torso
- In the event of a recognized, unavoidable side collision, the system can give the driver or front passenger a slight push towards the center of the vehicle on the side facing the impact
- This lateral impulse is initiated by very rapid inflation of an air chamber in the seat bolster

Competitive advantages of the E-Class Sedan

BMW 528i



- New E-Class has:
- Std. 18" wheels (vs. std 17" wheels)
- 9G-TRONIC Transmission (vs. 8-speed auto)
- 12.3-inch Display (vs 10.2-inch)
- Touch Control Buttons on steering wheel
- Power adjust. Front seats w/ lumbar support and 3-position memory for driver/passeng. (vs. driver only)
- LED Headlamps (vs Bi-Xenon)
- Apple CarPlay® & Android Auto
- PRE-SAFE® incl. PRE-SAFE® Sound

Audi A6 2.0 liter



- New E-Class has:
- Std. 18" wheels
- 9G-TRONIC Transmission (vs. 7 or 8-speed auto)
- 12.3-inch Display (vs 7-inch)
- Touch Control Buttons on steering wheel
- Power adjust. Front seats w/ lumbar support and 3-position memory for driver/passeng. (vs. driver only)
- LED Headlamps (vs Bi-Xenon)
- Apple CarPlay® & Android Auto
- PRE-SAFE® incl. PRE-SAFE® Sound

Lexus GS



- New E-Class has:
- Std. 18" wheels
- 9G-TRONIC Transmission (vs. 8-speed auto)
- 12.3-inch Display (vs 6.5-inch)
- Touch Control Buttons on steering wheel
- LED Headlamps
- Apple CarPlay® & Android Auto
- PRE-SAFE® incl. PRE-SAFE® Sound



Gallery

New Standard Key Design



Standard KEYLESS-START



Gallery

designo Black/Titanium Grey Peal (P62)



designo Macchiato Beige / Saddle Brown (P87)



Gallery

Ambient Lighting w/ 64 colors (877)



Ambient Lighting w/ 64 colors (877)



Gallery

Optional Panorama roof (413)



Optional Wood/leather steering wheel (L3D)

