

## Equipment

	E 220 d Sedan	E 350 d Sedan	E 200 Sedan	E 300 Sedan	E 300 4MATIC Sedan
<b>Drivetrain</b>					
9G-TRONIC	Code 421	Standard	Code 421	Standard	Standard
ECO start/stop function	Standard	Standard	Standard	Standard	Standard
<b>Chassis</b>					
AGILITY CONTROL suspension with selective damping system	Standard	Standard	Standard	Code 485	Standard
AGILITY CONTROL suspension with selective damping system and lowering	Code 677	Code 677	Code 677	Standard	Code 677
Suspension with adaptive damping adjustment	Code 459	Code 459	Code 459	Code 459	Code 459
DYNAMIC SELECT	Code B59	Standard	Code B59	Standard	Standard
AIR BODY CONTROL	Code 489	Code 489	Code 489	Code 489	Code 489
<b>Climate control</b>					
THERMATIC automatic air conditioning	Standard	Standard	Standard	Standard	Standard
THERMOTRONIC automatic air conditioning	Code 581	Code 581	Code 581	Code 581	Code 581
AIR-BALANCE package	Code P21	Code P21	Code P21	Code P21	Code P21
Stationary heater Including radio remote control	Code 228	Code 228	Code 228	Code 228	Code 228
Heated windshield	Code 597	Code 597	Code 597	Code 597	Code 597

## Axles and suspension

---

### **Suspension and damping**

The new E-Class is equipped as standard with conventional steel suspension with a road surface-dependent, passive damping system.

The multi-chamber air spring with AIR BODY CONTROL continuous adjustable damping system is available optionally. The suspension components comprise non-wheel-controlling suspension struts on the front axle, springs and dampers on the rear axle and torsion bars with torsion bar linkages for each axle. In combination with AIR BODY CONTROL, four level sensors and three acceleration sensors are implemented on the front and rear axles as of the market launch. Here, the level sensors are installed on the wheel control assemblies and the acceleration sensors are installed on the body.

### **AGILITY CONTROL suspension with selective damping system**

The comfortably tuned, conventional suspension/damping of the E-Class is designed as a road surface-dependent damping system. The front axle suspension strut is attached to the body with a triple-path head bearing. With this system, the static carrying forces are transmitted directly to the body via a plastic shim. Large forces (e.g. when shock absorbers bottom out) are absorbed by a jounce buffer.

The function module consists of a small elastomer piston, which reduces the damping effect in the event of minor road surface excitations. This considerably improves the driving comfort and the response of the suspension in particular. For heavier road surface excitation, the full damping effect is available.

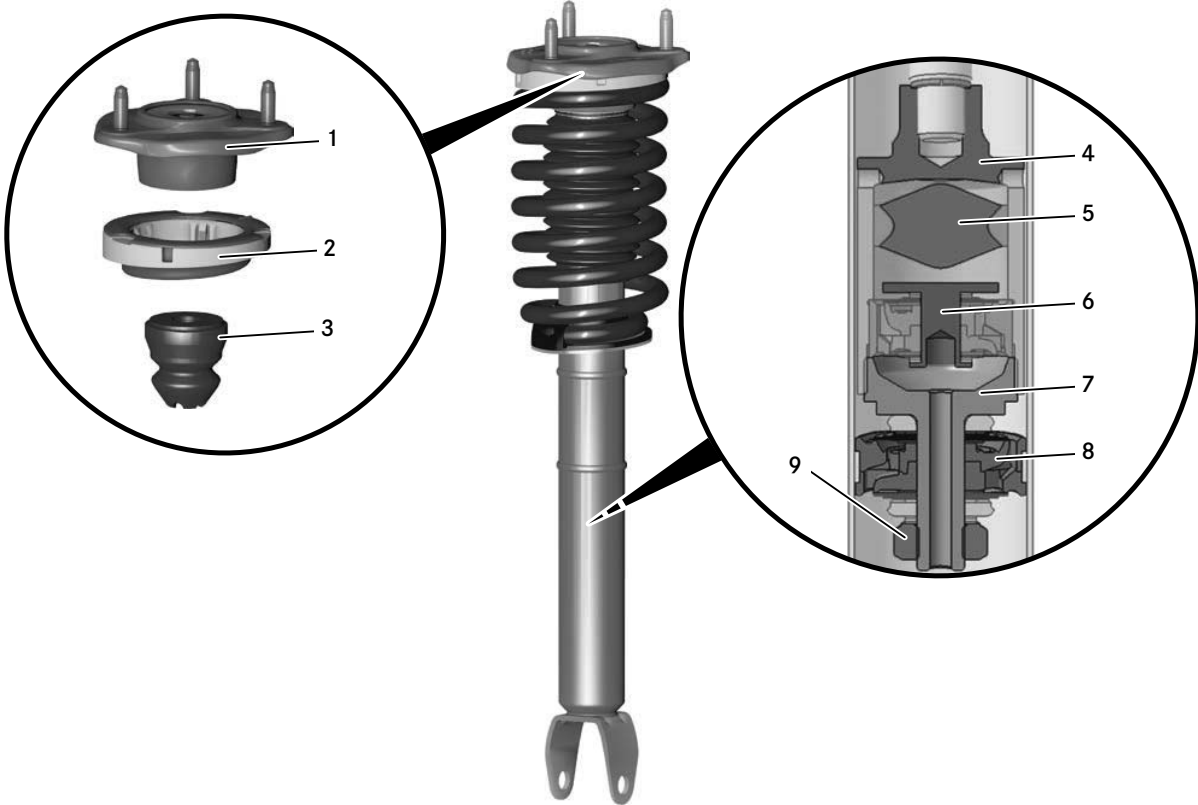

P32.25-2375-00

**AGILITY CONTROL suspension strut**

- |  |  |
|--|--|
| <ul style="list-style-type: none"> <li>1 Head bearing</li> <li>2 Plastic shim</li> <li>3 Jounce buffer</li> <li>4 Working housing</li> <li>5 Elastomer piston</li> </ul> | <ul style="list-style-type: none"> <li>6 Comfort valve with bypass separation</li> <li>7 Restrictor</li> <li>8 Working piston with bypass separation</li> <li>9 Nut</li> </ul> |
|--|--|

## Axles and suspension

### AIR BODY CONTROL

The AIR BODY CONTROL special equipment option provides multi-chamber air suspension on all four wheels. The system combines air suspension with continuous adjustment damping, whereby the damping characteristics are adjusted appropriately to the road surface condition.

The multi-chamber springs allow the air volume which supports the vehicle to be varied. The chambers can be separated or connected with each other by means of a valve. This varies the rigidity of the multi-chamber air springs and adjusts it to the driving situation. This results in less rolling when cornering. The supply of compressed air for the air suspension is achieved with an electrically powered compressor. As of the market launch, the system is equipped with a central reservoir to be able to regulate the vehicle load silently at a standstill. The driver can adjust the vehicle level individually by pressing the vehicle level button in the lower control panel.

The electronic control unit contains an automatic disabling function so that all control operations, such as air release from the suspension struts or compressor operation, are suppressed in certain situations e.g. when changing a wheel on a jack or when lifting the vehicle on a vehicle lift.

When the vehicle is fully laden, the air suspension guarantees excellent ride comfort. Depending on the current speed, the automatic ride-height control function can reduce the fuel consumption and improve the safety of the vehicle. In addition, the vehicle can be lifted on rough road surfaces or unfavorable uphill stretches using the vehicle level button in the lower control panel. The continuously adjustable damping system improves body stability in particular, whilst maintaining optimal driving comfort. Excellent vehicle dynamics can be achieved with the quick-responding adjustable damping system without any reduction in comfort. In evasive maneuvers, for example, this means that there is an immediate adjustment of the spring and damping forces to optimize the vehicle's anti-roll characteristics and roll torque distribution.

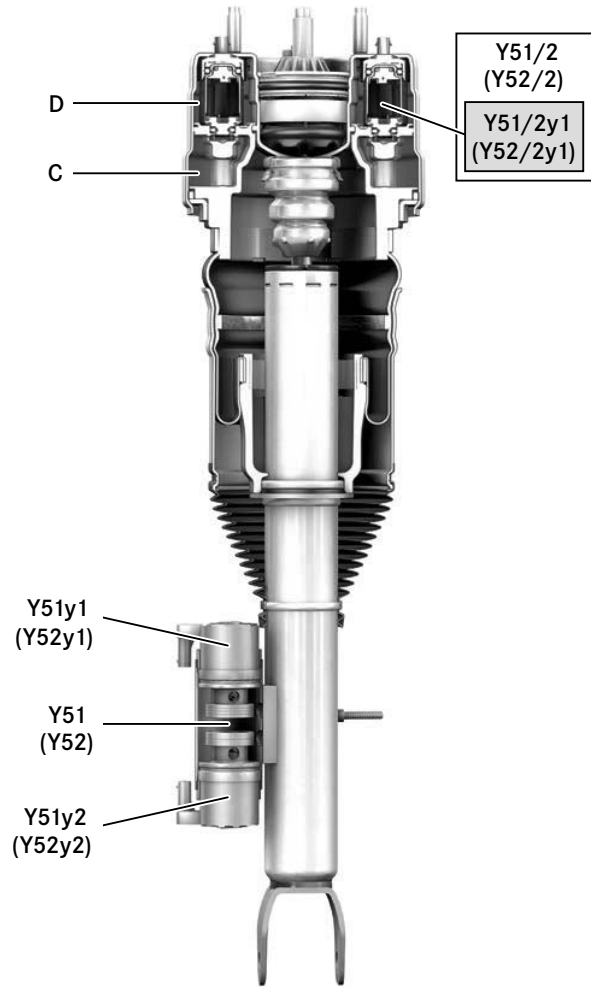

P32.22-2597-00

**AIR BODY CONTROL with continuous damping control illustrated on the front suspension strut**

C	Air chamber	Y52	Right front axle damping valve unit
D	Air chamber		
Y51	Left front axle damping valve unit	Y52y1	Solenoid valve 1, right front
Y51y1	Solenoid valve 1, left front	Y52y2	Solenoid valve 2, right front
Y51y2	Solenoid valve 2, left front		
Y51/2	Left front axle air suspension valve unit	Y52/2	Right front axle air suspension valve unit
Y51/2y1	Air suspension valve 1, left front	Y52/2y1	Air suspension valve 1, right front

## Axles and suspension

---

### **AGILITY CONTROL suspension with selective damping system and lowering**

The suspension with selective damping system is lowered by -15 mm. The lowering and tighter suspension tuning enables a dynamic driving style combined with high ride comfort. It also gives the vehicle a sporty appearance.

The suspension is equipped with continuously adjustable damping at the front and rear axle. Depending on the driving situation, vehicle speed and road surface condition, the system varies the damper characteristic and automatically reduces sprung mass vibrations of the body. It is possible to choose between Comfort, Sport and Sport Plus transmission modes. Each transmission mode allows the damping characteristics to be changed individually and conveniently. The driver is informed about the current mode setting on the multifunction display.