

# AMG E-Class Sedan



W213

Model Year 2020

Subject to Change

**AMG**  
DRIVING PERFORMANCE

## AMG E53/ E63 S

---



Models



What's new?



Standard Equipment



Exterior Paint Colors



Wheels



Interior Upholstery



Interior Trims



Option Packages



Stand-Alone Options



Options in Detail



Specifications



Specifications



*AMG E53 (213.061)*

- MSRP \$73,800
- AMG-enhanced 3.0L Inline-6 Turbo Engine with EQ Boost and Electric Auxiliary Compressor
- 429 hp @ 6,100 rpm
- 384 lb-ft @ 1,800 – 5,800 rpm
- EQ Boost Starter-Alternator outputs 21 hp
- 4.4 sec (est. 0-60 mph)
- Launch date: TBA



*AMG E63 S (213.089)*

- MSRP \$107,350
- Handcrafted AMG 4.0L V8 Biturbo engine
- 603 hp @ 5,750 – 6,500 rpm
- 627 lb-ft @ 2,500 – 4,500 rpm
- 3.3 sec (est. 0-60 mph)
- Launch date: TBA

## *Standard Equipment*

- AMG Illuminated Doorsills now standard on E 53
- AMG Performance Exhaust now standard on E 63 S
- AMG Drive Unit Steering Wheel Buttons (U88) now standard on E 63 S
- “Emotion Start” now available; hold the left steering wheel shift paddle while pressing the start button for a sporty engine start
- AMG DYNAMIC SELECT now includes “Slippery” mode for inclement weather (E 63 S)
- AMG DYNAMIC SELECT mode “Eco” replaced with “Slippery”; “Gliding” function now able to be adopted to the “Individual” mode (E 53)

## *Optional Equipment*

- AMG Matte Silver Fiberglass Trim now available (H84)
- AMG Performance Steering Wheel in DINAMICA now available (L6G)
- AMG Performance Steering Wheel in DINAMICA / Carbon Fiber now available (L6H)
- AMG Drive Unit Steering Wheel Buttons now optionally available on E 53 (U88)
- ENERGIZING Comfort Package is now available, including AIR BALANCE Cabin Air Fragrance & Filtration System (DB8)
- Ordering a wheel with R01 tires results in an increased top speed (E 53 only)
- All-Weather Floor Mats now available (D33)

## Performance & Handling

- AMG-enhanced 3.0L I6 Turbo engine (E 53 only)
- EQ Boost Starter-Alternator (E 53 only)
- Handcrafted AMG 4.0L V8 Biturbo engine (E 63 S only)
- AMG SPEEDSHIFT 9G TCT (Torque Converter Transmission) (E53 only)
- AMG SPEEDSHIFT® MCT 9-speed transmission (E 63 S only)
- AMG Performance 4MATIC+ (E 53 only)
- AMG Performance 4MATIC+ w/ Drift Mode (E 63 S only)
- AMG Sport Suspension based on AIR BODY CONTROL
- 19" AMG Wheels (E 53 only) / 20" AMG wheels (E 63 S)
- AMG DYNAMIC SELECT
- Dynamic engine mounts (E 63 S only)
- AMG electronic limited-slip differential (E 63 S only)
- AMG Performance Exhaust (E 63 S only)
- AMG Drive Unit Steering Wheel Buttons (E 63 S only)

## Comfort & Convenience

- 64-color Ambient lighting
- Bluetooth® connectivity
- COMAND® navigation
- LED headlamps and taillamps
- Power front seats w/ 3-position memory and 4-way power driver's lumbar support
- Power tilt/sliding sunroof
- Smartphone Integration with Apple CarPlay™ & Android Auto
- 40/20/40-split folding rear seats
- AMG Performance Steering Wheel with Touch Control Buttons
- Touchpad w/ central controller
- Mercedes me connect
- Active Parking Assist (E 63 S)
- 12.3" Digital Instrument Cluster
- SiriusXM® All-Access w/ trial period
- KEYLESS-START
- Comfort Package
- KEYLESS-GO® with HANDS-FREE ACCESS
- Electronic trunk closer
- IWC "Ingenieur" analog clock
- Heated and ventilated front seats (E 63 S)
- AMG Nappa leather upholstery (E 63 S only)
- Inductive Wireless Charging w/ NFC Pairing
- AMG Track Pace App (E 63 S)
- AMG Illuminated Door Sills

## Safety & Security

- Active Brake Assist
- ATTENTION ASSIST®
- Car-to-X Communication
- Crosswind Assist
- LED headlamps and taillamps
- PRE-SAFE®
- PRE-SAFE® Sound
- Tire Pressure Monitoring System (TPMS)
- Blind Spot Assist
- Rearview Camera (E 53 only)
- Surround View System (E 63 S)

## Non-metallic Paints

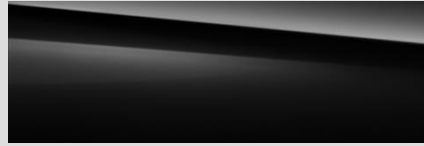

040  
Black  
*Option price: \$0*



149  
Polar White  
*Option price: \$0*

## Metallic Paints

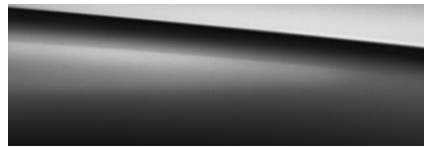

197  
Obsidian Black  
*Option price: \$720*

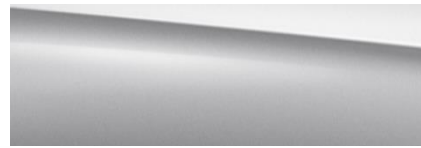

775  
Iridium Silver  
*Option price: \$720*

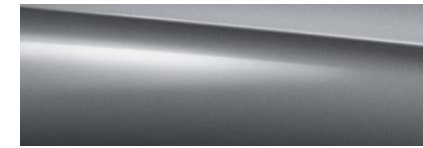

992  
Selenite Grey  
*Option price: \$720*



890  
Lunar Blue  
*Option price: \$720*

## *designo*<sup>®</sup> Paints



996  
Cardinal Red  
*Option price: \$1,080*



799  
Diamond White  
*Option price: \$1,515*



297  
Selenite Grey Magno  
*Option price: \$3,950*



RTE

19" AMG Twin 5-Spoke Wheels  
w/ Black Accents

R02, R66

*Option price: \$0*

*E53 Only*

RTN

20" AMG Twin 5-Spoke Wheels  
w/ Grey Accents

R01, R66

*Option price: \$750*

*E53 Only*

RTO

20" AMG Twin 5-Spoke Wheels  
w/ Black Accents

R01, R66

*Option price: \$750*

*E53 Only*

RVQ

20" AMG Multispoke Wheels  
w/ Grey Accents

R01, R66

*Option price: \$750*

*E53 Only*

RVR

20" AMG Multispoke Wheels  
w/ Black Accents

R01, R66

*Option price: \$750*

*E53 Only*



RTY

20" AMG Twin 5-Spoke Wheels  
R01

*Option price: \$750*

*E53 Only*



RTZ

20" AMG Twin 5-Spoke Wheels  
w/ Black Accents, R01

*Option price: \$750*

*E53 Only*





**RTM**  
20" AMG Twin 5-Spoke Wheels  
w/ Grey Accents  
R01, B51  
*Option price: \$0*  
*E63 S Only*

**RTQ**  
20" AMG Twin 5-Spoke Wheels  
w/ Matte Grey Accents  
R01, B51  
*Option price: \$0*  
*E63 S Only*

**RTP**  
20" AMG Twin 5-Spoke Wheels  
w/ Black Accents  
R01, B51  
*Option price: \$0*  
*E63 S Only*

**RTR**  
20" AMG Forged Cross-Spoke  
Wheels w/ Grey Accents  
R01, B51  
*Option price: \$1,200*  
*E63 S Only*

**RTS**  
20" AMG Forged Cross-Spoke  
Wheels, Matte Black  
R01, B51  
*Option price: \$1,700*  
*E63 S Only*





<i>Code</i>	<i>Wheel Size</i>	<i>Description</i>	<i>Wheel Dimensions</i>			<i>Mobility</i>	<i>MSRP</i>
RTE	19"	AMG Twin 5-Spoke Wheels w/ Black Accents <i>E 53 only</i>	245/40 R 19 on 8 J x 19	ET 20	(Front)	R02, R66	\$ 0
			275/35 R 19 on 9 J x 19	ET 49	(Rear)		
RTN	20"	AMG Twin 5-Spoke Wheels w/ Grey Accents <i>E 53 only</i>	245/35 ZR 20 on 8 J x 20	ET 20	(Front)	R01, R66	\$ 750
			275/30 ZR 20 on 9 J x 20	ET 49	(Rear)		
RTO	20"	AMG Twin 5-Spoke Wheels w/ Black Accents <i>E 53 only</i>	245/35 ZR 20 on 8 J x 20	ET 20	(Front)	R01, R66	\$ 750
			275/30 ZR 20 on 9 J x 20	ET 49	(Rear)		
RVQ	20"	AMG Multispoke Wheels w/ Grey Accents <i>E 53 only</i>	245/35 R 20 on 8 J x 20	ET 43	(Front)	R01, R66	\$ 750
			275/30 R 20 on 9 J x 20	ET 49	(Rear)		
RVR	20"	AMG Multispoke Wheels w/ Black Accents <i>E 53 only</i>	245/35 R 20 on 8 J x 20	ET 43	(Front)	R01, R66	\$ 750
			275/30 R 20 on 9 J x 20	ET 49	(Rear)		
RTY	20"	AMG Twin 5-Spoke Wheels <i>E 53 only</i>	245/35 R 20 on 8 J x 20	ET 43	(Front)	R01, R66	\$ 750
			275/30 R 20 on 9 J x 20	ET 49	(Rear)		
RTZ	20"	AMG Twin 5-Spoke Wheels w/ Black Accents <i>E 53 only</i>	245/35 R 20 on 8 J x 20	ET 43	(Front)	R01, R66	\$ 750
			275/30 R 20 on 9 J x 20	ET 49	(Rear)		
RTM	20"	AMG Twin 5-Spoke Wheels w/ Grey Accents <i>E 63 only</i>	265/35 ZR20 on 9.5J x 20	ET25	(Front)	R01, B51	\$ 0
			295/30 ZR20 on 10.0J x 20	ET55	(Rear)		
RTQ	20"	AMG Twin 5-Spoke Wheels w/ Matte Grey Accents <i>E 63 only</i>	265/35 ZR20 on 9.5J x 20	ET25	(Front)	R01, B51	\$ 0
			295/30 ZR20 on 10.0J x 20	ET55	(Rear)		
RTP	20"	AMG Twin 5-Spoke Wheels w/ Black Accents <i>E 63 only</i>	265/35 ZR20 on 9.5J x 20	ET25	(Front)	R01, B51	\$ 0
			295/30 ZR20 on 10.0J x 20	ET55	(Rear)		
RTR	20"	AMG Forged Cross-Spoke Wheels w/ Grey Accents <i>E 63 only</i>	265/35 ZR20 on 9.5J x 20	ET25	(Front)	R01, B51	\$ 1,200
			295/30 ZR20 on 10.0J x 20	ET55	(Rear)		
RTS	20"	AMG Forged Cross-Spoke Wheels, Matte Black <i>E 63 only</i>	265/35 ZR20 on 9.5J x 20	ET25	(Front)	R01, B51	\$ 1,700
			295/30 ZR20 on 10.0J x 20	ET55	(Rear)		



621

Black w/ Red Stitching <sup>1</sup>

*Standard; E 53 Only*

Not available with Warmth & Comfort Package (DB0) or  
Heated & Ventilated Front Seats (401)

*Choose between Red or Black Seatbelts (Y05, U17)*

# Interior Upholstery – AMG Nappa Leather



821

Black w/ Red Stitching <sup>1</sup>

Option price: \$2,990

*E 53 Only*

*Choose between Red or Black Seatbelts (Y05, U17)*



861

Black <sup>1</sup>

Option price: \$2,990

*E 53 Only*



864

Nut Brown / Black <sup>1</sup>

Option price: \$2,990

*E 53 Only*



865

Macchiato Beige / Black <sup>1</sup>

Option price: \$2,990

*E 53 Only*

# Interior Upholstery – AMG Exclusive Nappa Leather



554  
Nut Brown / Black <sup>1</sup>  
Option price: \$0  
E 63 Only



555  
Macchiato Beige / Black <sup>1</sup>  
Option price: \$0  
E 63 Only



561  
Black w/ Silver Stitching <sup>1</sup>  
Option price: \$0  
E 63 Only



554 w/ optional AMG Performance Seat (555)  
Nut Brown / Black <sup>1</sup>  
Option price: \$2,500  
E 63 Only



555 w/ optional AMG Performance Seat (555)  
Macchiato Beige / Black <sup>1 2</sup>  
Option price: \$2,500  
E 63 Only



561 w/ optional AMG Performance Seat (555)  
Black w/ Silver Stitching <sup>1</sup>  
Option price: \$2,500  
E 63 Only



<i>Code</i>	<i>Upholstery</i>	<i>Seats</i>	<i>Floor Mats</i>	<i>Upper Dash/Lower Dash</i>	<i>Seat Belts</i>	<i>Steering Wheel</i>	<i>Headliner</i>
621	Black MB-Tex / DINAMICA w/ Red Stitching	Black	Black	Black / Black	Red or Black	Black	Black Cloth <sup>1</sup>
821	Black w/ Red Stitching Nappa Leather	Black	Black	Black / Black	Red or Black	Black	Black Cloth <sup>1</sup>
861	Black Nappa Leather	Black	Black	Black / Black	Black	Black	Black Cloth <sup>1</sup>
864	Nut Brown / Black Nappa Leather	Nut Brown	Black	Black / Nut Brown	Black	Black	Black Cloth <sup>1</sup>
865	Macchiato Beige / Black Leather	Macchiato Beige	Black	Black / Macchiato Beige	Black	Black	Black Cloth <sup>1</sup>
554	Nut Brown Exclusive Nappa Leather	Nut Brown	Black	Black / Nut Brown	Black	Black	Black Cloth <sup>1</sup>
555	Macchiato Beige Exclusive Nappa Leather	Macchiato Beige	Black	Black / Macchiato Beige	Black	Black	Black or Macchiato Beige Cloth <sup>1 2</sup>
561	Black w/ Silver Stitching Exclusive Nappa Leather	Black	Black	Black / Black	Silver or Black	Black	Black Cloth <sup>1</sup>

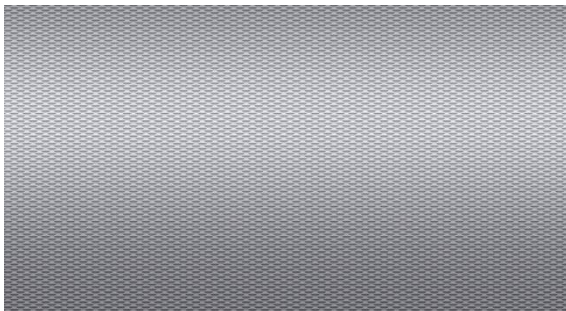

739

Aluminum  
Option price: \$0

*Includes Black Piano Lacquer Center Console (728)*

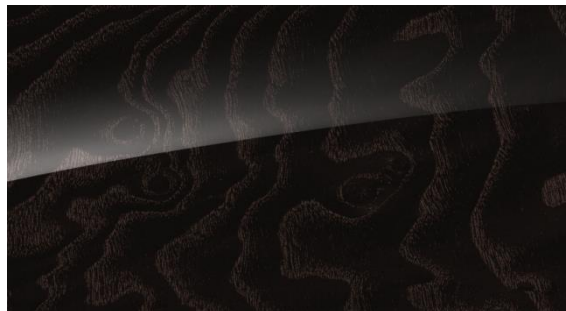

H06

Brown Ash Wood  
Option price: \$0

*Includes Brown Ash Wood Center Console (656)*



H09

Natural Grain Brown Ash Wood  
Option price: \$0

*Includes Natural Grain Brown Ash Wood Center Console (730)*



736

Natural Grain Black Ash Wood  
Option price: \$0

*Includes Natural Grain Black Ash Wood Center Console (737)*

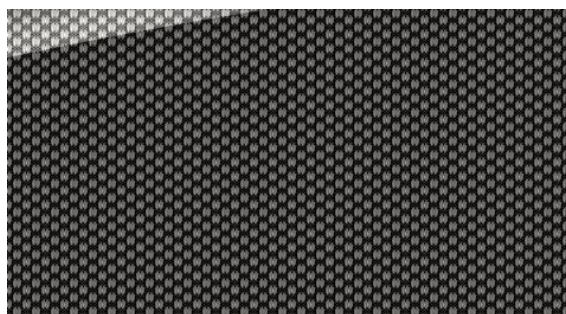

H64

Metal Weave  
Option price: \$600

*Includes Black Piano Lacquer Center Console (728)*

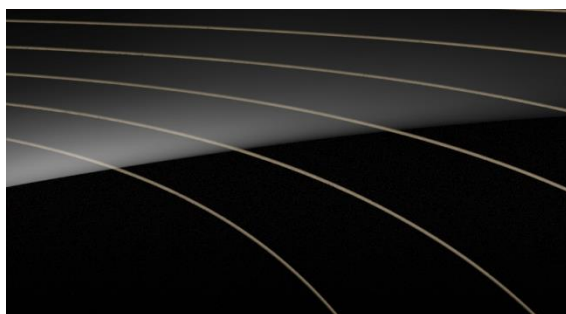

H16

*designo* Black Piano Lacquer Flowing Lines  
Option price: \$1,300

*Includes Black Piano Lacquer Center Console (728)*

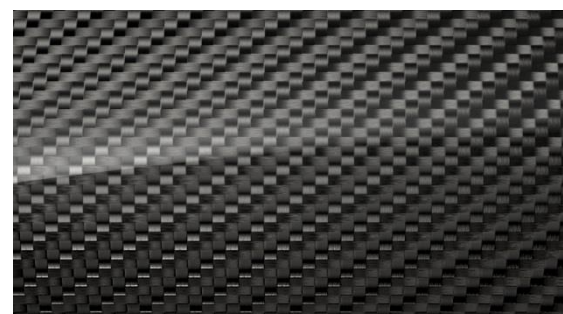

H73

AMG Carbon Fiber  
Option price: \$2,850

*Includes AMG Carbon Fiber Center Console (732)*

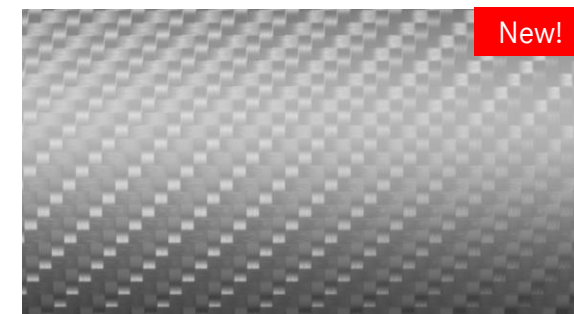

H84

AMG Matte Silver Fiberglass  
Option price: \$2,850

*Includes AMG Matte Silver Fiberglass Center Console (733)*

# Interior Trims – Center Console Trim



728

Center Console in Black Piano Lacquer

*Included w/ upper trims 739, H64, H16*



730

Center Console in Natural Grain Brown Ash Wood

*Requires Natural Grain Brown Ash Wood trim (H09)*



737

Center Console in Natural Grain Black Ash Wood

*Requires Natural Grain Black Ash Wood trim (736)*



732

Center Console in AMG Carbon Fiber

*Requires AMG Carbon Fiber trim (H73)*



656

Center Console in Brown Ash Wood

*Included w/ Brown Ash Wood trim (H06)*



733

Center Console in AMG Matte Silver Fiberglass

*Included w/ AMG Matte Silver Fiberglass trim (H84)*

Details on Image might differ from actual center console

Code	Packages	Availability	MSRP
DA2	<p><b>Driver Assistance Package</b>  <i>Not with Blind Spot Assist (234), Active Brake Assist (258), or AMG Performance Seats (555)</i></p> <ul style="list-style-type: none"> <li>▪ P20 – Driver Assistance Plus Package code</li> <li>▪ K32 – Active Lane Change Assist</li> <li>▪ K34 – Route Based Speed Adaptation</li> <li>▪ 233 – Active Distance Assist DISTRONIC®</li> <li>▪ 253 - PRE-SAFE PLUS Rear End Collision Protection</li> <li>▪ 266 – Active Steering Assist</li> <li>▪ 269 – Active Brake Assist w/ Cross-Traffic Function</li> <li>▪ 292 – PRE-SAFE® Impulse Side</li> <li>▪ 546 – Active Speed Limit Assist</li> <li>▪ Active Emergency Stop Assist, Evasive Steering Assist, Active Blind Spot Assist and Active Lane Keeping Assist</li> <li>▪ Extended Restart by Stop &amp; Go up to three seconds</li> </ul> <p><b>When ordered with Parking Assistance Package (DA3), extended restart by Stop &amp; Go up to 30 seconds</b></p>	All Models	\$ 2,250
DE0	<p><b>Driver Assistance Package for AMG Performance Seats</b>  <i>Not with Blind Spot Assist (234) or Active Brake Assist (258).</i>  <i>Requires AMG Performance Seats (555).</i></p> <ul style="list-style-type: none"> <li>▪ 23P – Driver Assistance Package code</li> <li>▪ K32 – Active Lane Change Assist</li> <li>▪ K34 – Route Based Speed Adaptation</li> <li>▪ 233 – Active Distance Assist DISTRONIC®</li> <li>▪ 253 - PRE-SAFE PLUS Rear End Collision Protection</li> <li>▪ 266 – Active Steering Assist</li> <li>▪ 269 – Active Brake Assist w/ Cross-Traffic Function</li> <li>▪ 546 – Active Speed Limit Assist</li> <li>▪ Active Emergency Stop Assist, Evasive Steering Assist, Active Blind Spot Assist and Active Lane Keeping Assist</li> <li>▪ Extended Restart by Stop &amp; Go</li> </ul> <p><b>When ordered with Parking Assistance Package (DA3), extended restart by Stop &amp; Go up to 30 seconds</b></p>	All Models	\$ 2,250



<i>Code</i>	<i>Packages</i>	<i>Availability</i>	<i>MSRP</i>
DA3	<b>Parking Assistance Package</b> <ul style="list-style-type: none"> <li>▪ P47 – Parking Assist code</li> <li>▪ 235 – Active Parking Assist</li> <li>▪ 501 – Surround View System</li> </ul>	E 53 Standard on E 63 S	\$ 1,290
DA4	<b>Advanced Lighting Package</b> <ul style="list-style-type: none"> <li>▪ P35 – Advanced Light Package Code</li> <li>▪ 608 – Adaptive Highbeam Assist</li> <li>▪ 640 – LED Intelligent Light System</li> </ul>	All Models	\$ 800
DB0	<b>Warmth and Comfort Package</b> <i>Not available w/ heated front seats (873); not in conjunction w/ stand-alone option 902</i> <i>Selecting Warmth and Comfort Package omits AMG Drive Unit Steering Wheel Buttons (U88)</i> <ul style="list-style-type: none"> <li>▪ P68 – Warmth and Comfort Package code</li> <li>▪ 443 – Heated Steering Wheel</li> <li>▪ 902 – Rapid Heating Functionality for Front Seats</li> <li>▪ 906 – Heated Armrest</li> </ul>	All Models	\$ 1,050
DB8	<b>ENERGIZING Comfort Package</b> <i>Recommended w/ Multicontour Front Seats w/ Massage Feature (399) and Warmth &amp; Comfort Package (DB0) for full ENERGIZING Comfort functionality</i> <ul style="list-style-type: none"> <li>▪ P72 – ENERGIZING Comfort Package code</li> <li>▪ P21 – AIR BALANCE Cabin Air Purification and Fragrance System</li> </ul>	All Models	\$ 550
DB9	<b>Sun Protection Package</b> <ul style="list-style-type: none"> <li>▪ P09 – Sun Protection Package Code</li> <li>▪ 313 – Rear window manual roller blinds</li> <li>▪ 540 – Power Rear-Window Sunshade</li> </ul>	All Models	\$ 800
DC2	<b>Acoustic Comfort Package</b> <ul style="list-style-type: none"> <li>▪ PAF – Acoustic Comfort Package Code</li> <li>▪ 596 – Heat-insulating, noise-insulating and infrared-reflecting laminated glass</li> </ul>	All Models	\$ 1,100

Code	Packages	Availability	MSRP
DC1	<b>AMG Night Package</b> <i>Can be combined with AMG Exterior Carbon Fiber Packages</i>	E 53	\$ 650
	<ul style="list-style-type: none"> <li>▪ P60 - AMG Exterior Night Styling (<i>E 53 Only</i>)</li> <li>▪ High-gloss black elements: front splitter, front flics, trim strip on rear apron</li> <li>▪ Black Chrome elements: tailpipe in black chrome trim</li> </ul>		E 63 S
	<ul style="list-style-type: none"> <li>▪ P60 - AMG Exterior Night Styling (<i>E 63S Only</i>)</li> <li>▪ High-gloss black elements: front splitter, mirror housings, side fender inserts, window frame trim, trim strip on rear apron</li> <li>▪ Black Chrome elements: tailpipe in black chrome trim</li> <li>▪ U50 - Omission of Dark Tinted Glass (<u>US Regulatory requirement</u>)</li> </ul>		
DE7	<b>AMG Exterior Carbon Fiber Package I</b> <i>Can be combined with AMG Night Package (DC1)</i> Carbon fiber elements: Front splitter, side fender inserts, side sill panel inserts, and insert in rear apron above rear diffuser	E 63 S	\$ 2,950
DC4	<b>AMG Exterior Carbon Fiber Package II</b> <i>Can be combined with AMG Night Package (DC1)</i> <ul style="list-style-type: none"> <li>• AMG carbon fiber exterior mirror covers</li> <li>• AMG carbon fiber trunk lid spoiler</li> </ul>	All Models	\$ 1,750

# Stand-Alone Options



DRIVING PERFORMANCE

<i>Code</i>	<i>Options</i>	<i>Availability</i>	<i>MSRP</i>
256	<b>AMG Track Pace App</b> <i>(Standard on E 63 S)</i>	E 53	\$ 250
401	<b>Heated and Ventilated Front Seats</b> <i>(Standard on E 63 S)</i> Not available with AMG Black MB-Tex / DINAMICA w/ Red Stitching (621)	E 53	\$ 450
413	<b>Panorama Roof</b>	All Models	\$ 1,000
432	<b>Active Multicontour Front Seats with Massage Feature</b> <i>Not available with AMG Performance seats (555). Requires Nappa Leather upholstery. Requires Warmth &amp; Comfort Package (DB0) or Rapid Heating Front Seats (902).</i>	All models	\$ 1,320
443	<b>Heated Steering Wheel</b> <i>Also included in Warmth &amp; Comfort Package (DB0); not available w/ AMG Drive Unit Steering Wheel Buttons (U88)</i>	All Models	\$ 250
463	<b>Head-Up Display</b>	All Models	\$ 1,100
555	<b>AMG Performance Seats</b> <i>Not available with Active Multicontour Seats w/ Massage Function (432) &amp; Driver Assistance Package (DA2)</i>	All Models	\$ 2,500
581	<b>3-Zone Climate Control</b>	All Models	\$ 760
811	<b>Burmester® High-End 3D Surround Sound System</b>	All Models	\$ 4,550
872	<b>Heated Rear Seats</b>	All Models	\$ 580
883	<b>Soft-Close Doors</b>	All Models	\$ 550
902	<b>Rapid Heating Front Seats</b> <i>Only w/ Active Multicontour Front Seats with Massage Feature (432)</i>	All Models	\$ 450
61U	<b>designo Black DINAMICA Headliner</b> <i>Requires Sun Protection Package (DB9)</i>	All Models	\$ 1,600
65U	<b>designo Macchiato Beige DINAMICA Headliner</b> <i>Requires Sun Protection Package (DB9); only with Macchiato Beige AMG Exclusive Nappa Leather (555)</i>	E 63 S	\$ 1,600
U80	<b>115V AC Power Outlet</b>	All Models	\$ 115

# Stand-Alone Options



DRIVING PERFORMANCE

<i>Code</i>	<i>Options</i>	<i>Availability</i>	<i>MSRP</i>
B07	<b>AMG High-Performance Ceramic Composite Braking System</b>	E 63 S	\$ 8,950
B14	<b>AMG Carbon Fiber Engine Cover</b>	E 63 S	\$ 1,500
U78	<b>AMG Performance Exhaust System</b> <i>(Standard on E 63 S)</i>	E 53	\$ 1,250
U88	<b>AMG Drive Unit Steering Wheel Buttons</b> <i>(Standard on E 63 S)</i> <i>n/a with Warmth &amp; Comfort Package (DB0) or Heated Steering Wheel (443)</i>	E 53	\$ 400
L6J	<b>AMG Performance Steering Wheel in Nappa Leather</b> <i>(Standard on E 53)</i>	E 63 S	\$ 0
L6K	<b>AMG Performance Steering Wheel in Nappa Leather / DINAMICA</b> <i>(Standard on E 63 S)</i>	E 53	\$ 500
L6L	<b>AMG Performance Steering Wheel in Nappa Leather / Black Piano Lacquer</b> <i>Requires 739, H16 or H64 Trim</i>	E 53 E 63 S	\$ 600 \$ 100
L6G	<b>AMG Performance Steering Wheel in DINAMICA</b> <i>n/a with Warmth &amp; Comfort Package (DB0) or Heated Steering Wheel (443); requires AMG Drive Unit (U88)</i>	E 53 E 63 S	\$ 600 \$ 100
L6H	<b>AMG Performance Steering Wheel in DINAMICA / Carbon Fiber</b> <i>Must have one of the following trims: H64, H73, 736, 739</i>	E 63 S	\$ 400
260	<b>Deletion of Rear Deck Lid Badging</b>	All Models	\$ 0
261	<b>Deletion of Fender Badging</b>	All Models	\$ 0
U17	<b>Black Seatbelts</b> <i>Requires upholstery options: 621, 821, 561</i>	All Models	\$ 0
Y04	<b>Silver Seatbelts</b> <i>Only with 561 Upholstery</i>	E 63	\$ 0
Y05	<b>Red Seatbelts</b> <i>Only with 621 or 821 Upholsteries</i>	E 53	\$ 0
<i>Code</i>	<i>Special Order Options (SPC) – Implies \$250 Charge</i>		<i>MSRP</i>
293	<b>Rear Side Air Bags</b>		\$ 420

# Stand-Alone Options



DRIVING PERFORMANCE

<i>Code</i>	<i>VPC Installed Accessories</i>	<i>Availability</i>	<i>MSRP</i>
D03	<b>Illuminated Star</b> <i>Not with Driver Assistance Package (DA2) or Driver Assistance Package for AMG Performance Seats (DE0)</i>	All models	\$ TBA
D07	<b>Wheel Locking Bolts</b>	All models	\$ TBA
D08	<b>Chrome Door Handle Inserts</b> <i>(Set of 4)</i>	All models	\$ TBA
D28	<b>Comfort Box</b>	All models	\$ TBA
D32	<b>AMG Crest LED Projectors</b> <i>(Set of 2)</i>	All models	\$ TBA
D33	<b>New!</b> <b>All-weather mats</b>	All models	\$ TBA



## AMG-enhanced 3.0L Inline-6 Turbo Engine w/ EQ Boost and Electric Auxiliary Compressor



### AMG-enhanced 3.0L Inline-6 Turbo Engine w/ EQ Boost and Electric Auxiliary Compressor (M256)

The M256 engine found in AMG “53” models provides exceptional power output thanks to exciting new technologies:

- EQ Boost:
  - The M256 utilizes a 48V system to provide power to the electric water pump, AC compressor, Electric Auxiliary Compressor. With these components now being electrified, the engine is now fully beltless, reducing wearable parts.
  - EQ Boost makes use of the stored electric power from the 48V battery with an “Integrated Starter-Generator” which combines the starter and alternator in a powerful electric motor which is positioned between the engine and transmission. This EQ Boost unit assists the internal combustion engine with up to 21 hp and 184 lb-ft of torque at low engine speeds.
    - *Please note that this boost in hp / torque never impacts the certified peak power figures, as the boost is generated at such low engine speeds, and only for brief periods of time.*
  - On overrun, EQ Boost is able to recover up to 80 percent of the energy to the 48V battery.
  - The engine is able to start very quietly by utilizing stored power in the 48V battery. ECO Start/Stop is also almost imperceptible now that it uses the EQ Boost system.
    - *Please note that the 48V battery is small- it is a little less than 1 kWh in capacity.*
  - The conventional 12V battery is still used by the vehicle and is charged by the 48V battery. Most electrical vehicle components remain wired for 12V and thus, the 12V battery is used to provide power for cabin lights, exterior lighting, the multimedia system, etc.
- Electric Auxiliary Compressor:
  - This new engine component (exclusive to the “53” models) is able to assist in spooling the engine’s exhaust-gas-driven turbocharger quickly and effectively at low-to-mid RPMs. Able to get up to speeds of 70,000 RPMs within less than a third of a second, the eAC is extremely quick to provide added boost. This allows a much larger turbocharger to be employed in this version of the M256. In some cases, boost from the Electric Auxiliary Compressor is able to be routed directly to the engine itself.
  - In one minute, the Electric Auxiliary Compressor is able to function three times for two seconds, or one time for 15 seconds.

## *Handcrafted AMG 4.0L V8 biturbo engine (M177 E40DEH LA AMG)*



Handcrafted AMG 4.0L V8 Biturbo engine (M177 E40DEH LA AMG)  
E 63 S

- **Aluminum crankcase** featuring a racing inspired closed-deck design
  - The area around the cylinders' coolant enclosure is closed off at the top and is only perforated by cooling channels
  - This makes the engine block more rigid and able to withstand greater loads
- **Forged, lightweight aluminum pistons** – high performance and low weight
- **Two Twin-scroll turbochargers** with separate exhaust channels
  - Positioned between the cylinder heads for faster response
  - Inspired by Formula 1
  - Keeps engine compact, improves turbo response and lowers emissions
  - Separate exhaust channels prevent turbos from having a negative impact on each other during load/directional changes, and enables faster spooling/buildup of turbo pressure
- **Dynamic Engine Mounts** – Adjust to DYNAMIC SELECT mode and driving conditions
  - “Soft Mounts” for Comfort – Reduces engine noise and vibration
  - “Hard Mounts” for Sport – Increases steering precision
- **Variably Adjustable Inlet and Outlet Valves**
  - Filled with sodium
  - Light weight

## *U88 AMG Drive Unit Steering Wheel Buttons: \$400*



### **AMG Drive Unit Steering Wheel Buttons**

- When U88 is selected, the AMG Performance Steering Wheel is equipped with a round controller with an integral display beneath the right-hand steering wheel spoke, plus two vertically positioned color display buttons beneath the left-hand steering-wheel spoke
- The round display allows for easy adjustment of the AMG DYNAMIC SELECT Drive Mode
- The vertically-mounted displays offer a configurable hot-key to adjust two key parameters, i.e. a switch to Manual transmission mode (or to Automatic shifting) or a switch from the Comfort exhaust setting to the more emotional Sport setting
- These buttons allow the driver to concentrate fully on dynamic driving without having to take their hands off the wheel in order to change performance-oriented vehicle settings

*Please note that AMG Drive Unit Steering Wheel Buttons are not able to be equipped in conjunction with Warmth and Comfort Package (DB0) or Heated Steering Wheel (443).*

*AMG Drive Unit Steering Wheel Buttons are required in conjunction with AMG Performance Steering Wheel in DINAMICA (L6G).*



## *Brakes*



### **AMG Sport Brakes**

*Standard on E 53 (E 53 only)*

4-piston front and 1-piston rear calipers

- Front axle: brake disc measuring 14.6 inch, internally ventilated and perforated with 4-piston fixed caliper
- Rear axle: brake discs measuring 14.2 inch, internally ventilated 1-piston floating caliper
- Grey-painted brake calipers with “AMG” lettering



### **AMG High-Performance Composite Braking System (U70)**

*Standard on E 63 S (E 63 S only)*

6-piston front and 1-piston rear calipers

- Front axle: composite brake disc measuring 15.4 x 1.4 inch, internally ventilated and perforated with 6-piston fixed caliper
- Rear axle: brake discs measuring 14.2 x 1.0 inch, internally ventilated and perforated with 1-piston floating caliper
- Increased fade resistance and reduced thermal deformation of brake discs
- Red-painted brake calipers with “AMG” lettering

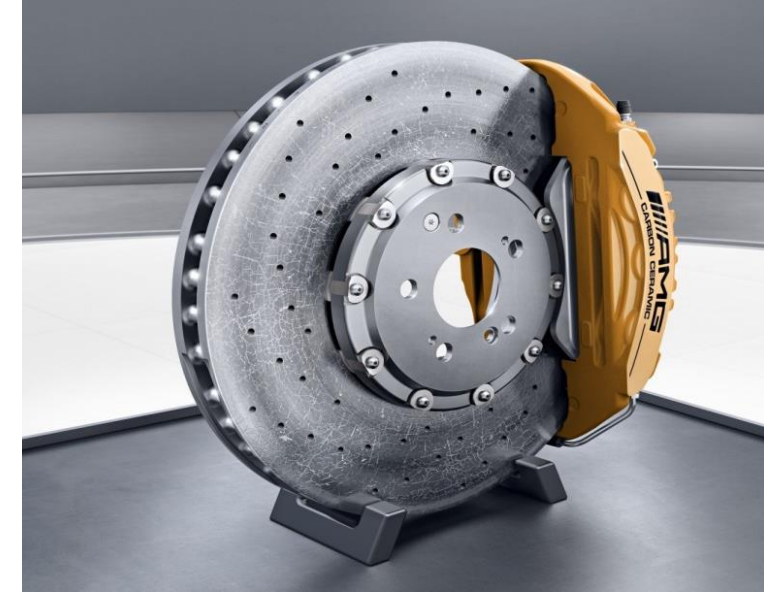

### **AMG High-Performance Ceramic Composite Braking System (B07)**

*Option price: \$TBA (E 63 S only)*

6-piston front and 1-piston rear calipers

- Front axle: composite ceramic disc with a diameter of 15.8 x 1.5 inch, internally ventilated and perforated, with 6-piston fixed caliper
- Rear axle: integral brake disc with a diameter of 14.2 x 1.3 inch, internally ventilated and perforated with 1-piston floating brake caliper
- 40% weight savings compared to conventional brake discs
- Bronze-painted brake calipers with “AMG Carbon Ceramic” lettering

## Advisory on B07 AMG High-Performance Ceramic Compound Braking System



The AMG Ceramic Composite Braking system has numerous benefits – namely, it is 40% lighter than a conventional steel braking system, offers significantly longer service life for the brake rotors, and provides exceptional resistance to brake fade under repeated aggressive stops.\*

The materials in your AMG Ceramic Compound Braking system were derived from Formula One technology, and therefore will perform differently than conventional brakes.

Especially when cold, this ceramic composite material will resonate during braking and potentially feel less responsive under light brake pressure but with no loss in braking power. You will hear sounds, e.g. squealing, that you might not expect and which may be louder than what you are used to during ordinary everyday braking maneuvers – rest assured that this is a normal operating characteristic for this brake system, and is a by-product of the unique properties of the material. Mercedes-AMG recommends that the driver engage the brakes in an assertive manner in order to mitigate some of this noise during normal operation; Mercedes-AMG also recommends that the brakes be brought up to operating temperature before use in high-performance driving situations in order to improve braking performance.

*\*Brake weight based on AMG Germany official measurements, Service life based on F1 Safety car longevity and is dependent on individual driving style and conditions and will vary. Brake pads and rotors should be regularly serviced to ensure proper wear. Please reference your Mercedes-AMG Maintenance Booklet or contact your dealer for scheduled intervals.*

## *Steering Wheels*



**AMG Performance Steering Wheel in Nappa Leather (L6J)**

*Standard*

- The AMG Performance Steering Wheel in Nappa Leather is especially sporty with easy grip, providing genuine racing flair.



**AMG Performance Steering Wheel in Nappa Leather / DINAMICA (L6K)**

*Optional*

- Sporty design and unique touch & feel make the AMG Performance Steering Wheel an unmistakable feature in Nappa Leather with the grip area in DINAMICA.



**AMG Performance Steering Wheel in Nappa Leather / Black Piano Lacquer (L6L)**

*Optional; Requires H64, H40 or H16 trim*

- The combination of leather with Black Piano Lacquer or Leather with high-gloss Black Poplar Wood makes the steering wheel a highlight in terms of its look and feel.



**AMG Performance Steering Wheel in DINAMICA (L6G)**

*Optional; not available with DB0 or 443; must have U88.*

- For an even better grip during sporty maneuvers, the AMG Performance Steering Wheel with flattened bottom section is fully trimmed in DINAMICA.

## *Steering Wheels*



**AMG Performance Steering Wheel in  
DINAMICA / Carbon Fiber (L6H)**

*Optional*

- For an even better grip during sporty maneuvers, the grip area on the AMG Performance Steering Wheel in Carbon Fiber is finished in DINAMICA.

## AMG Performance Seats (555): \$2,500



## AMG Performance Exhaust System (U78)



### **AMG Performance Exhaust System (U78)**

*Option price: \$1,250*

*Standard on E 63 S*

- Stronger differentiation of the sound characteristics by means of two additional exhaust flaps
- Sound characteristics dependent on selected drive program – clear differentiation between rich in drive programs “C” and “S” and emphatically sporty in drive programs “S+” and “Race” (*“Race” mode on E 63 S Only*)
- Additional control of the sound characteristics by means of a button in the middle control panel of the center console
- Control by means of variably adjustable exhaust flaps – without loss of power
- Control of the exhaust gas flaps is dependent on both engine speed and load, ensuring 100% power delivery
- Double declutching (in “S”) and a misfire (in “S+” and “Race” emphasize the sporty characteristics of the particular drive programs (*“Race” mode on E 63 S Only*))

## *AMG Night Package (pictured on the E 63 S) (DC1) E 63 S: \$750; E 53: \$650*



Window trim strip in high-gloss black



AMG rear apron trim in high-gloss black

Black chrome-plated twin tailpipe trim elements



Mountings on the louvres of the outer air intakes in high-gloss black

A-wing in high-gloss black

Lamella grille in silver chrome

## AMG Exterior Carbon Fiber Package I (DE7) - E 63 S Only: \$TBA



Carbon fiber inserts in AMG side sill panels



Carbon fiber insert in rear apron above rear diffuser



A-wing in carbon fiber

Lamella grille in silver chrome



***AMG Exterior Carbon Fiber Package II (DC4) on all models (E 63 S shown): \$1,750***



AMG carbon fiber rear spoiler



AMG carbon fiber exterior mirror covers

## AMG Track Pace



### AMG Track Pace

Standard on E 63 S; \$250 on E 53

AMG TRACK PACE transforms your AMG vehicle into your virtual race engineer. With the aid of lap, sector and acceleration times plus selected live telematics data you can analyse and improve your driving skill on cordoned-off tracks in a targeted manner.

In order to determine as precise a position as possible, AMG TRACK PACE works with a specially programmed algorithm which combines vehicle data such as wheel speed, steering angle and yaw rate with the satellite-aided GPS positioning system and updates every 50 milliseconds (20 Hz technology). This makes position measurement significantly more precise than with external applications such as third-party-provider apps on a smartphone.

In order to record and continually improve your individual performance, recorded data such as lateral and longitudinal acceleration, accelerator and brake pedal position or steering angle are used. All values are clearly depicted and can be read out directly in the vehicle. Fast or slow laps can be noted from the corner of the eye thanks to various colour displays.

As well as recording drives on circuits or public routes, AMG TRACK PACE can also be used to record accelerations such as from 0 – 60 mph or over a quarter mile, plus deceleration values. Measurement with AMG TRACK PACE starts automatically when driving off or in deceleration mode when falling below a certain speed.

AMG TRACK PACE stores individual laps and sprints in the vehicle database. You can determine a reference time and compare your current drive with it – down to the last centimeter. This saves you any heavy and difficult to use additional equipment for analysing your driving data.

## *Build Recommendation for the E 53 Sedan*

Model	E 53 Sedan	E 53 Sedan	E 53 Sedan
<b>Exterior Color</b>	<b>149</b> Polar White	<b>890</b> Lunar Blue Metallic	<b>197</b> Obsidian Black Metallic
<b>Upholstery</b>	<b>621</b> AMG Black MB Tex / DINAMICA w/ Red Stitching	<b>621</b> AMG Black MB Tex / DINAMICA w/ Red Stitching	<b>861</b> AMG Black Nappa Leather
<b>Option Package</b>	<b>DA2</b> Driver Assistance Pkg. <b>DA4</b> Exterior Lighting Pkg. <b>DC1</b> AMG Night Pkg.	<b>DA2</b> Driver Assistance Pkg. <b>DA3</b> Parking Assistance Pkg. <b>DA4</b> Exterior Lighting Pkg. <b>DB9</b> Sun Protection Pkg.	<b>DA2</b> Driver Assistance Pkg. <b>DA3</b> Parking Assistance Pkg. <b>DA4</b> Exterior Lighting Pkg. <b>DB0</b> Warmth and Comfort Pkg. <b>DB9</b> Sun Protection Pkg. <b>DC1</b> AMG Night Pkg.
<b>Wheel</b>	<b>RTE</b> 19" AMG Twin 5-Spoke Wheels w/ Black Accents + <b>R02</b> Tires	<b>RTN</b> 20" AMG Twin 5-Spoke Wheels w/ Grey Accents + <b>R01</b> Tires	<b>RTZ</b> 20" AMG Twin 5-Spoke Wheels w/ Black Accents + <b>R01</b> Tires
<b>Trim</b>	<b>736+737</b> Natural Grain Black Ash Wood	<b>H64+728</b> Metal Weave	<b>H73+732</b> AMG Carbon Fiber
<b>Standalone Options</b>	<b>256</b> AMG Track Pace <b>U80</b> 115V AC Power Outlet <b>Y05</b> Red Seatbelts  <b>Standard equipment needed to complete NETSTAR order:</b> <b>51U</b> Black Headliner <b>810</b> Burmester Surround Sound System <b>414</b> Glass Sunroof <b>873</b> Heated Front Seats <b>L6J</b> AMG Performance Steering Wheel in Nappa Leather	<b>256</b> AMG Track Pace <b>U17</b> Black Seatbelts <b>U78</b> AMG Performance Exhaust <b>U80</b> 115V AC Power Outlet  <b>Standard equipment needed to complete NETSTAR order:</b> <b>51U</b> Black Headliner <b>810</b> Burmester Surround Sound System <b>414</b> Glass Sunroof <b>873</b> Heated Front Seats <b>L6J</b> AMG Performance Steering Wheel in Nappa Leather	<b>256</b> AMG Track Pace <b>401</b> Heated and Ventilated Front Seats <b>413</b> Panorama Sunroof <b>432</b> Active Multicontour Front Seats <b>L6K</b> AMG Performance Steering Wheel in Nappa Leather / DINAMICA <b>U17</b> Black Seatbelts <b>U78</b> AMG Performance Exhaust <b>U80</b> 115V AC Power Outlet  <b>Standard equipment needed to complete NETSTAR order:</b> <b>51U</b> Black Headliner <b>810</b> Burmester Surround Sound System
<b>Estimated MSRP</b>	<b>TBA</b>	<b>TBA</b>	<b>TBA</b>

## *Build Recommendation for the E 63 S Sedan*

Model	E 63 S Sedan	E 63 S Sedan	E 63 S Sedan
<b>Exterior Color</b>	<b>040</b> Black	<b>996 designo</b> Cardinal Red Metallic	<b>890</b> Lunar Blue Metallic
<b>Upholstery</b>	<b>555</b> AMG Macchiato Beige / Black Exclusive Nappa Leather	<b>561</b> AMG Black Exvclusive Nappa Leather w/ Silver Stitching	<b>554</b> AMG Nut Brown / Black Exclusive Nappa Leather
<b>Option Package</b>	<b>DA2</b> Driver Assistance Pkg. <b>DA4</b> Exterior Lighting Pkg. <b>DC1</b> AMG Night Pkg.	<b>DA2</b> Driver Assistance Pkg. <b>DA4</b> Exterior Lighting Pkg. <b>DB0</b> Warmth and Comfort Pkg. <b>DB9</b> Sun Protection Pkg.	<b>DA2</b> Driver Assistance Pkg. <b>DA4</b> Exterior Lighting Pkg. <b>DB9</b> Sun Protection Pkg. <b>DC1</b> AMG Night Pkg. <b>DC4</b> Carbon Fiber Pkg. <b>DE0</b> Driver Assistance Pkg. for Perf. Seats
<b>Wheel</b>	<b>RTP</b> 20" Twin 5-Spoke Wheels w/ Black Accents	<b>RTS</b> 20" AMG Forged Cross-Spoke Wheels, Matte Black	<b>RTS</b> 20" AMG Forged Cross-Spoke Wheels, Matte Black
<b>Trim</b>	<b>736+737</b> Natural Grain Black Ash Wood	<b>H64+728</b> Metal Weave	<b>H73+732</b> Carbon Fiber
<b>Standalone Options</b>	<b>L6K</b> AMG Performance Steering Wheel in Nappa Leather / DINAMICA <b>U80</b> 115V outlet  <b>Standard equipment needed to complete NETSTAR order:</b> <b>51U</b> Black Headliner <b>810</b> Burmester Surround Sound System <b>414</b> Glass Sunroof	<b>413</b> Panorama Sunroof <b>432</b> Active Multicontour Seats <b>61U designo</b> Black DINAMICA Headliner <b>L6K</b> AMG Performance Steering Wheel in Nappa Leather / DINAMICA <b>U80</b> 115V outlet <b>Y04</b> Silver Seatbelts  <b>Standard equipment needed to complete NETSTAR order:</b> <b>810</b> Burmester Surround Sound System	<b>463</b> Head-up Display <b>555</b> AMG Performance Seats <b>61U</b> Black DINAMICA headliner <b>L6G</b> AMG Performance Steering Wheel in DINAMICA <b>U80</b> 115V outlet  <b>Standard equipment needed to complete NETSTAR order:</b> <b>810</b> Burmester Surround Sound System <b>414</b> Glass Sunroof
<b>Estimated MSRP</b>	<b>Approx. \$TBA</b>	<b>Approx. \$TBA</b>	<b>Approx. \$TBA</b>

	<i>E 53 Sedan</i>	<i>E 63 S Sedan</i>
Engine Configuration	AMG-enhanced 3.0L inline-6 turbo with EQ Boost & Electric Aux. Compressor	Handcrafted AMG 4.0L V8 biturbo engine
ICE Power (hp)	429 @ 6,100	603 @ 5,750 – 6,500
EQ Boost Starter-Alternator (hp)	21	n/a
ICE Torque (lb-ft)	384 @ 1,800 – 5,800	627 @ 2,500 – 4,500
Displacement (cc)	2,999	3,982
Acceleration 0-60 mph (sec)	4.4	3.3
Fuel Economy (Cty/Hwy/Comb)	TBA	TBA
Top Speed (mph)	TBA (electronically limited)	186 (electronically limited)
Fuel Requirement (Octane)	91	91
Compression	10.5:1	8.6:1
Transmission	AMG SPEEDSHIFT TCT 9G	AMG SPEEDSHIFT MCT 9G
Transmission Speeds	9	9
Drive Configuration	AMG Performance 4MATIC+	AMG Performance 4MATIC+ w/ Drift Mode
Fuel Tank Size (gallons)	21.1	21.1
Trunk Size (cubic feet)	13.1	13.1
Curb Weight (lbs)	TBA	TBA
Vehicle Length (in.)	195.2	196.4
Vehicle Width w/ exterior mirrors (in.)	81.3	81.3
Vehicle Height (in.)	57.0	56.6
Wheelbase (in.)	115.7	115.7
Track Width Front/Rear (in.)	64.1 / 62.9	64.9/62.8
Coefficient of Drag (Cd)	tbd	0.32

# Specifications – E 63 S Sedan

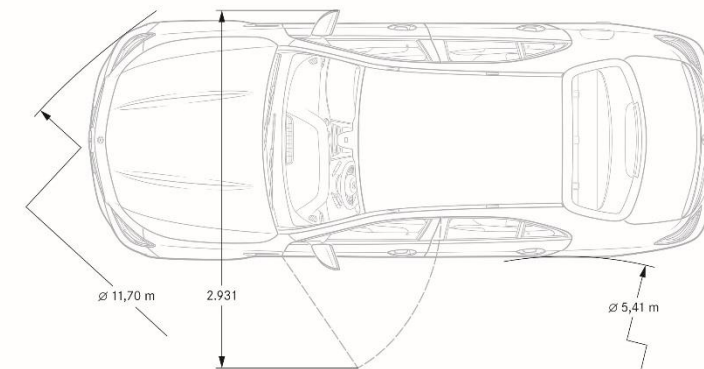
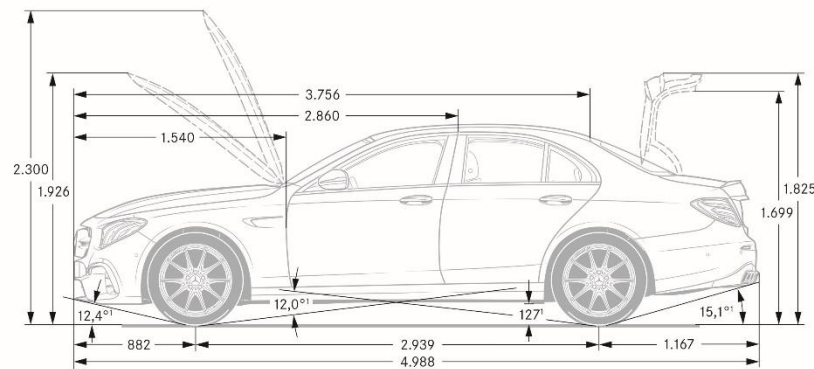
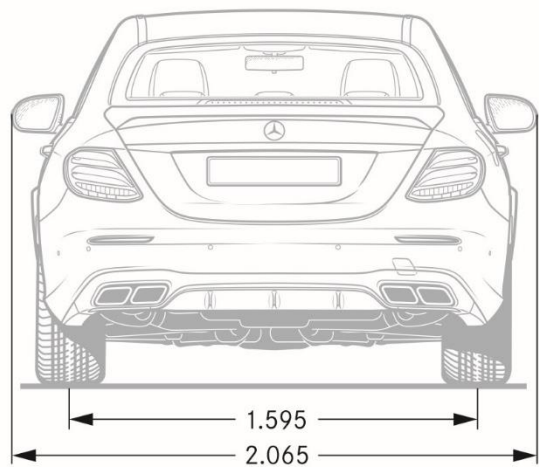
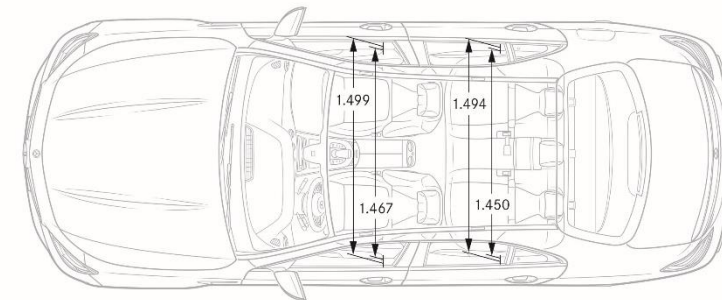
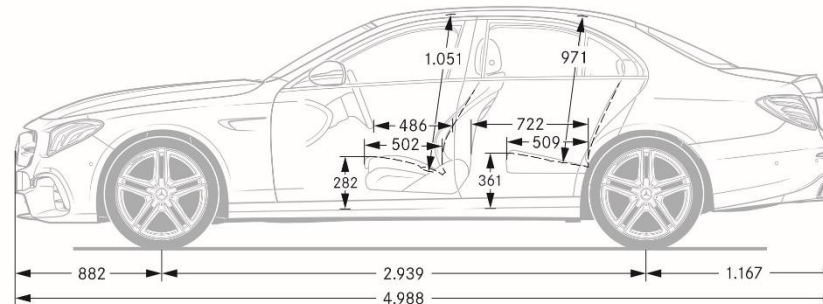
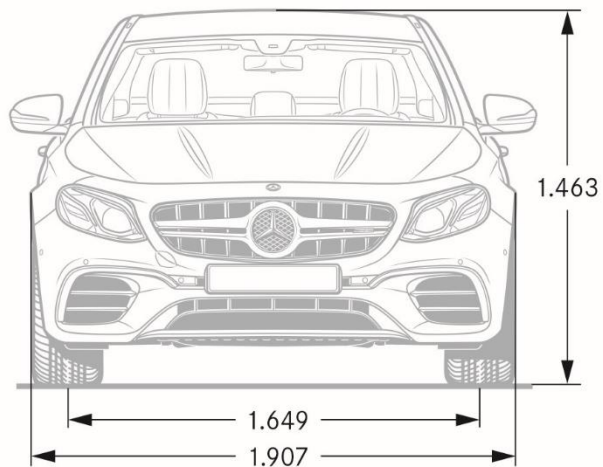

# Specifications – E 53 Sedan

