

Model 205, 213 (except 213.061/261), 253, 293

Advics 4-piston fixed-caliper brake

Model 205, 213 (except 213.061/261), 253

Brembo 4-piston fixed-caliper brake

Modification notes

01.10.2019 Document completely revised.

Shown on Brembo 4-piston fixed-caliper brake, on left side of vehicle

- 1 Pin
- 2 Retaining spring
- 3 Brake linings
- 4 Brake caliper
- 5 Brake piston

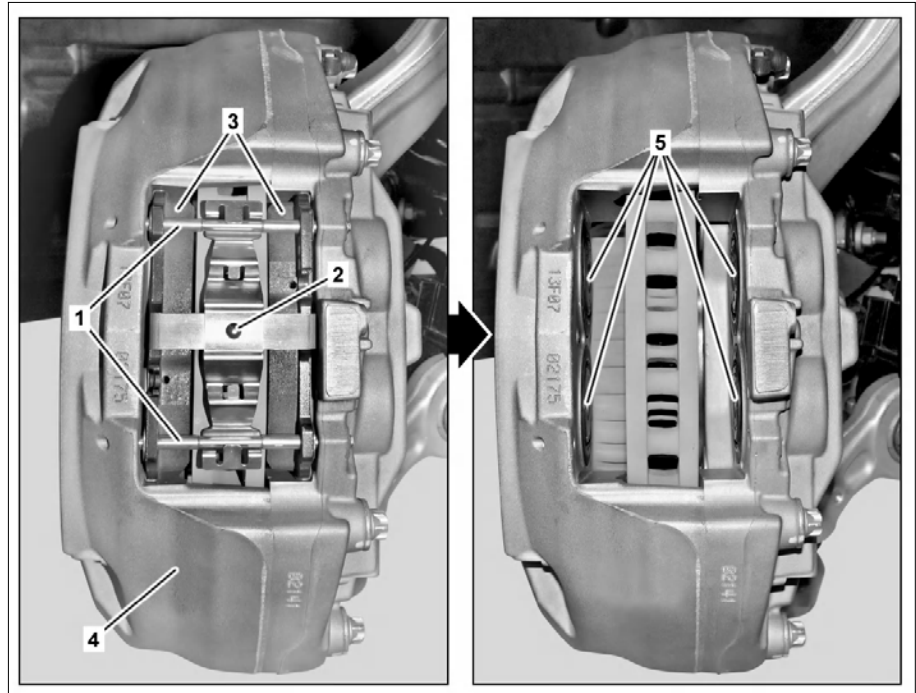

P42.10-3019-06

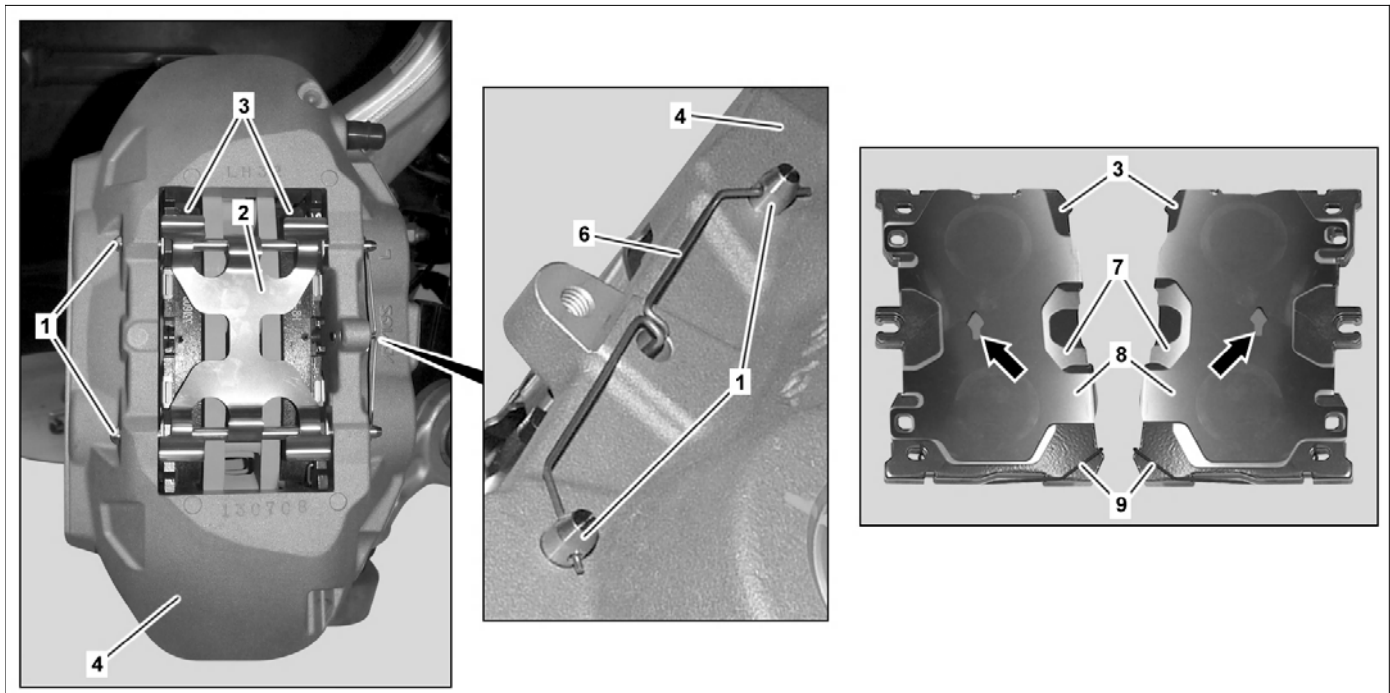

P42.10-3020-09

Shown on Advics 4-piston fixed-caliper brake, on left side of vehicle

1 Pin

4 Brake caliper

8 Soundproofing panels





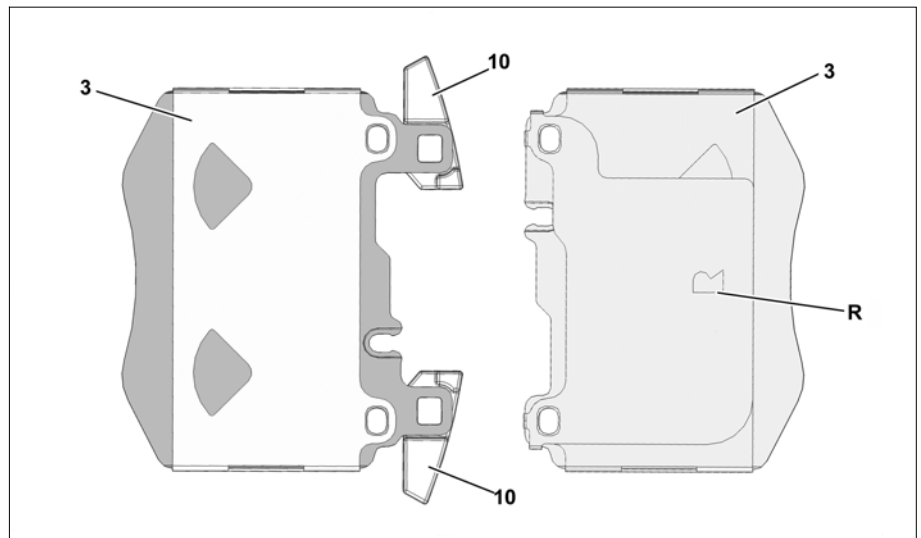





Shown on right brakepad with additional masses





- 3 Brake lining
- 10 Additional mass
- R Right side



P42.10-A013-05

	Risk of accident when commissioning the vehicle due to a lack of braking effect when the service brake is operated for the first time after repair work.	Before starting the engine, actuate brake pedal several times until pressure is built up and maintained in the brake system.	AS42.50-Z-0002-01A
⚠ Warning	Risk of injury . Skin or eye injuries may result when handling hot or glowing objects.	Wear protective gloves, protective clothing and safety glasses, if necessary.	AS00.00-Z-0002-01A
⚠ Caution	Risk of poisoning from swallowing brake fluid. Risk of injury from skin and eye contact with brake fluid	Only pour brake fluid into suitable and appropriately marked containers. Wear protective clothing and eye protection when handling brake fluid.	AS42.50-Z-0001-01A
	Notes on handling, transport and storage of composite brake disks		AH42.10-P-9406-12LF
	Notes on repairs to brake system		AH42.00-P-0003-01A
	Brake fluid notes		AH42.50-P-0001-01A
	Notes on safety-relevant components		AH00.00-Z-0019-01A
🔧	Remove		
1	Remove cover above brake fluid expansion reservoir.		
2	Clean area around cap on brake fluid expansion reservoir.	Assembly cleaner	*BR00.45-Z-1028-04A
3	Unscrew cap on brake fluid expansion reservoir and suction off some brake fluid.	i This prevents the expansion reservoir overflowing when the brake piston (5) is pushed back. i Commercially available devices/tools Extraction device for brake fluid	
4	Remove front wheels.		AR40.10-P-1102A
5	Expose electric line of right front brakepad wear sensor and release and disconnect electrical connector.	i Pay attention to the routing of the electrical line of the right front brakepad wear sensor.	
6	Unhook safety spring (6) from bolts (1) with pliers and remove.	Model 205, 213 (except 213.061/261), 253, 293Advics 4-piston fixed-caliper brake i Commercially available devices/tools Pliers	
7	Drive out bolts (1) using a punch and remove retaining springs (2).	i Commercially available devices/tools Drift	
8	Release brakepads (3) from brake pistons (5).	Model 205, 213 (except 213.061/261), 253Brembo 4-piston fixed-caliper brake i The brake linings (3) are bonded and must be replaced due to the loosened bonding.	
9	Remove brakepads (3).		
10	Pull right front brakepad wear sensor (S10/2) out of backing plate of brakepad (3).	When replacing the brake linings (3) or replacing the right front brake wear sensor. i Pay attention to the installation location of the right front brakepad wear sensor.	
🔍	Check		
11	Check bolts (1) and retaining spring (2) for damage and condition.	If there is a problem, ↓	

		Replace pin (1) or retaining spring (2).	
12	Check condition of soundproofing panels (7, 8) and springs (9).	Model 205, 213 (except 213.061/261), 253, 293Advics 4-piston fixed-caliper brake If there is a problem, ↓ Replace brakepads (3). i Soundproofing panels (7, 8), springs (9) and brakepads (3) only available as a set. i Only install brakepads (3) approved by Mercedes-Benz as a set.	
13	Check brakepads (3) for wear and condition.    	Model 205, 213 (except 213.061/261), 253, 293Advics 4-piston fixed-caliper brake Model 293 Model 205 Model 213 (except 213.061/261) Model 253 If there is a problem, ↓ Replace brakepads (3). i Only install brakepads (3) approved by Mercedes-Benz as a set.	AP42.10-P-4252EQ AP42.10-P-4252CAA AP42.10-P-4252E AP42.10-P-4252D
14	Check brake disks for wear and condition. 	i Replace brake disks as a complete set only. If there is a problem, ↓ Replace brake disks. Model 205, 213 (except 213.061/261), 253 Model 293	AP42.10-P-4256EW AR42.10-P-0220EWE AR42.10-P-0230EQ
15	Check brake caliper (4) with detachable parts for damage.	If there is a problem, ↓ replace corresponding component parts.	AR42.10-P-0070LWA
16	Press back brake pistons (5) using pusher tool.	i Secure brake pistons (5) against slipping out using two  wedges.  Wedge  Resetting device If the brake pistons (5) can only move sluggishly, ↓ replace brake caliper (4).	*601589076300 *000589524300 AR42.10-P-0070LWA
	Install		
17	Clean contact surfaces of brakepads (3) on brake caliper (4) and brake pistons (5).	 Do not use sharp-edged or pointed objects. Otherwise, the brake caliper (4) or the dust boots of the brake pistons (5) will be damaged. i Model 205, 213 (except 213.061/261), 253Brembo 4-piston fixed-caliper brake Completely remove adhesive residue on contact surfaces of brake pistons (5). Assembly cleaner	*BR00.45-Z-1028-04A
18	Insert front right brakepad wear sensor into backing plate of brakepad (3).	When replacing the brake linings (3) or replacing the right front brake wear sensor.	
19	Apply brake paste to brake caliper (4).	Model 213 (except 213.061/261), 293Front-axle 4-piston fixed-caliper brake MB Plastilube brake paste (brownish)	AR42.10-P-0163-01LW *BR00.45-Z-1084-06A
20	Remove protective foils from bonding surfaces of brake linings (3).	Model 205, 213 (except 213.061/261), 253Brembo 4-piston fixed-caliper brake	
21	Apply brake paste to brakepads (3).	Brakepads (3) without additional masses (10). Model 205, 213 (except 213.061/261), 253 Brembo 4-piston fixed-caliper brake Model 213 (except 213.061/261), 293Advics 4-piston fixed-caliper brake i Only install brakepads (3) with additional masses (10) when dry. i The brake paste to be used depends on the manufacturer of the brake caliper. MB Plastilube brake paste (brownish)	AR42.10-P-0162-01LWO *BR00.45-Z-1084-06A

22	Insert brakepads (3).	<p>i When installing brakepads (3) with additional masses (10), install these internally. Install brakepads (3) with right side (R) and left side installation markings externally on the appropriate side.</p> <p>i Model 205, 213 (except 213.061/261), 253, 293Advics 4-piston fixed-caliper brake Ensure correct installation position of soundproofing panels (7, 8). The springs (9) must be fitted to the underside of the brakepads (3). When installed, the arrows on the brakepads (3) must face forward in the direction of travel in the direction of rotation of the brake disk.</p> <p>i Only install brakepads (3) approved by Mercedes-Benz as a set.</p>	
23	Insert retaining spring (2) and pound bolts (1) in up to end stops.	i Check retaining spring (2) is correctly seated.	
24	Hook safety spring (6) in bolt (1) using pliers.	Model 205, 213 (except 213.061/261), 253, 293Advics 4-piston fixed-caliper brake i Commercially available devices/tools Pliers	
25	Route electric line of right front brakepad wear sensor (S10/2) and connect and lock electrical connector.		
26	Install front wheels.		AR40.10-P-1102A
27	Screw down cap of brake fluid expansion reservoir.		
28	Operate brake pedal several times until the brakepads (3) make contact with the brake disks.	i Firm resistance should be noticeable at the brake pedal.	
	Check		
29	Check and correct brake fluid level in expansion reservoir.	Model 2054-piston fixed-caliper brake Model 213 (except 213.061/261), 2534-piston fixed-caliper brake Model 293	AP42.10-P-4210CAA AP42.10-P-4210B AP42.10-P-4210F
  			
30	Install cover above brake fluid expansion reservoir.		
31	Perform brake test on test stand.		AP42.00-P-4290BA

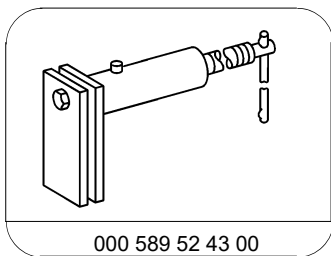

000 589 52 43 00

Resetting device

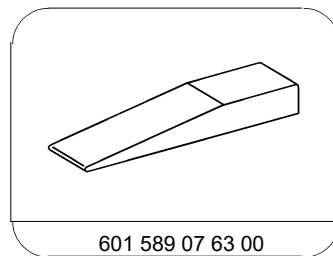

601 589 07 63 00

Wedge

Repair materials

Number	Designation	Order number
BR00.45-Z-1028-04A	Assembly cleaner	A 000 986 56 01
BR00.45-Z-1084-06A	MB Plastilube brake paste (brownish)	A 002 989 37 51