

FILE: SERVICE: GROUP 00 OF SERVICE INFORMATION BINDER  
PARTS: GROUP I OF INFORMATION – PARTS & ACCESSORIES BINDER

Campaign No. 2010110008, January 2011

TO: ALL MERCEDES-BENZ CENTERS

SUBJECT: **Model 463, Model Years 2002 - 2010**  
**Remove Headlamp Grill, Replace Front Turn Signal Lenses**

Daimler AG (DAG) has determined that certain model year 2002-2010 G-Class vehicles equipped with and dealer installed (accessory) headlamp and front fender turn signal grills fail to conform to the requirements of Federal Motor Vehicle Safety Standard (FMVSS) No. 108 S7.8.5, "Lamps, Reflective Devices, and Associated Equipment." Mercedes-Benz USA, LLC (MBUSA) therefore has initiated a recall of these vehicles. (Rear tail lamp grills are not affected by this recall).

The headlamps of the affected vehicles are equipped with a protective grill for protection of the headlamps during off-highway operation. FMVSS 108 S7.8.5 specifies that a grill shall not be installed in front of the lamp. The affected vehicles with the protective grills installed fail to meet all luminosity requirements of FMVSS 108 thereby increasing the risk of a crash. The affected vehicles may also be equipped with an allowable grill cover for front turn signal protection which also affects compliance with FMVSS 108 by reducing the turn signals' light visibility to other motorists.

Attached is a sample copy of a letter which owners of the affected vehicles will receive.

Prior to performing this Recall Campaign:

- Please check VMI to insure the vehicle is involved and to determine if the vehicle has been previously repaired.
- Please review the entire Recall Campaign bulletin.

Approximately 4,474 vehicles are involved.

Order No. P-RC-2010110008

This bulletin has been created and maintained in accordance with MBUSA-SLP S423QH001, Document and Data Control, and MBUSA-SLP S424HH001, Control of Quality Records.

## Procedure

### 1. Check front turn signal and headlamp grills:

- If headlamp grills are installed in **brush guard**: Proceed to step 2.
- If headlamp grills are installed in **headlamp trim**: Proceed to step 3.
- If grills are installed over the **turn signals** on the front fenders: Proceed to step 4.
- If grills are installed over the **turn signals** on the front fenders **and** if headlamp grills are also installed in brush guard perform steps 2 and 4.
- If grills are installed over the **turn signals** on the front fenders **and** if headlamp grills are also installed in **headlamp trim** perform steps 3 and 4.

### Note:

If equipped, do **not** remove tail lamp grills.

### 2. Remove headlamp grill (B, Figure 1):

- Remove bolt (A) and two screws (arrows) then remove headlamp grill (B) from front brush guard (C). Repeat this step on opposite side.
- Clean area of brush guard where headlamp grills (B) were installed.

### Note:

- Brush guards must **not** be installed again
- All parts removed in this step **must** be returned to the QEC.
- Cost of parts removed in this step must be reimbursed to customer. Refer to parts reimbursement table on page 4.
- Cost of aftermarket (non Mercedes-Benz genuine) parts removed in this step must **not** be reimbursed to customer.

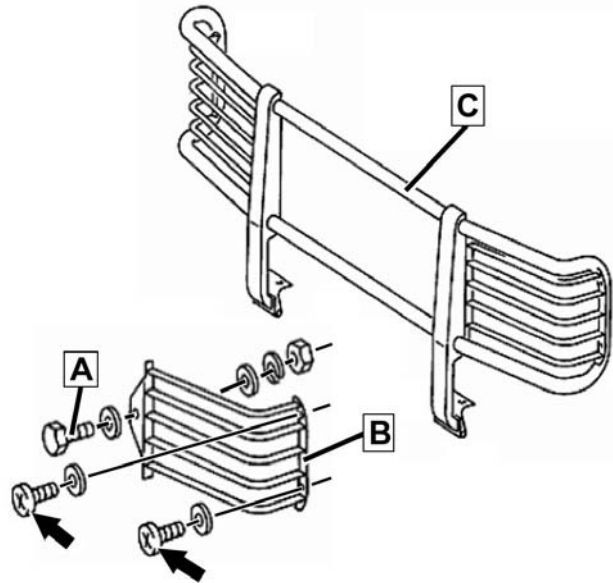

Figure 1

3. Replace headlamp trim (A, Figure 2):

- Remove headlamp trim (A) with head lamp grill (arrow); refer to WIS: AR88.00-P-2100G.

**Note** (Regarding above WIS instructions):

- If equipped with brush guard, lower brush guard to access headlamp trim (refer to Practical Hints chapter in Operator's Manual).
- For models with headlamp washers: Transfer washer nozzles from old headlamp trim (A) to new headlamp trim (A).
- Be careful not to scratch paint when removing and installing headlamp trim (A).
- Install new trim (A) (without grill mounting holes) painted in same color as vehicle.

**Note:**

- All parts removed in this step **must** be returned to the QEC.
- Cost of parts removed in this step must be reimbursed to customer. Refer to parts reimbursement table on page 4.
- Cost of aftermarket (non Mercedes-Benz genuine) parts removed in this step must **not** be reimbursed to customer.

4. Replace front turn signal lenses (B, Figure 3):

- Open directional grill (A).
- Remove 2 screws (arrows) then remove lens (B).
- Install new lens (B) in reverse order.

**Note:**

Use only **hand tools** to tighten screws (arrows), do **not** over-tighten screws (arrows).

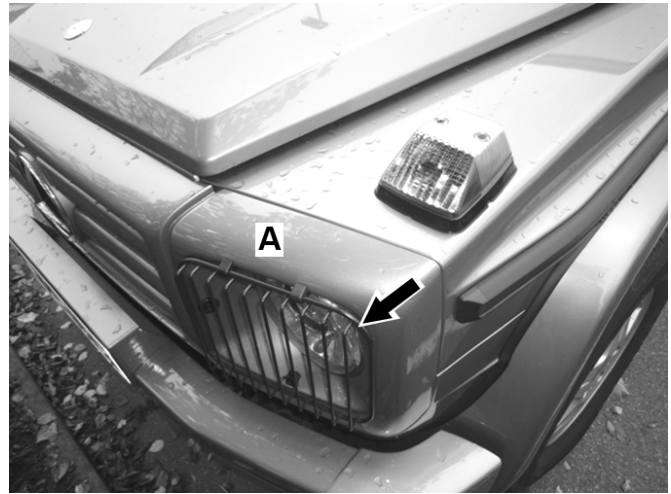

**Figure 2**

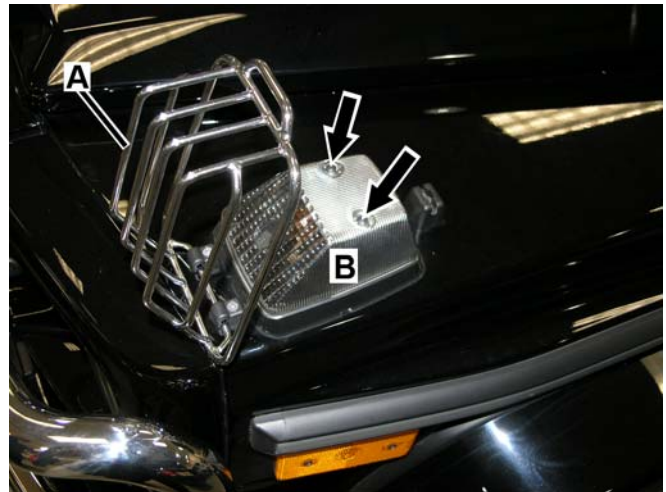

**Figure 3**

**Customer Reimbursement Parts Information**

Qty.	Part Name	Part Number	Reimbursement Amount
1	Brush Guard Grill Kit - Polished (refer to Figure 1)	BGP58500*	\$585.00
1	Brush Guard Grill Kit - Black (refer to Figure 1)	BGB14700*	\$147.00
1	Headlamp Grill (refer to Figure 2)	HLG42100*	\$421.00

\* Includes cost to reimburse customer for the original part, the labor to install, and sales tax. The local purchase part which corresponds with the parts being removed from the customer's vehicle should be submitted on the same line as the campaign (Qty. 1). These parts will be requested by the QEC to ensure accuracy. The Dollar amount indicated is the amount to be reimbursed to the customer. Non Mercedes-Benz grill accessories will not be reimbursed.

**Primary Parts Information**

Qty.	Part Name	Part Number	Estimated Replacement Rate
1	Right headlamp unit trim	A 463 884 08 31 05	10%
1	Left headlamp unit trim	A 463 884 07 31 05	10%
2	Front turn signal lens	A 463 822 00 27 05	90%

**Note:**

- Please be aware that only the part number(s) referenced in the Campaign Bulletin is approved for use to repair the vehicle. Repairs performed using any other part(s) will not have been performed in accordance with the campaign. Accordingly, warranty claims submitted with reference to an improper part number(s) will be denied.
- The following allowable labor operation should be used when submitting a warranty claim for this repair:
- The following warranty "Repair" scenarios 1-6 also apply if protective grills were installed as an **accessory**. Operation number: 02-7006 includes visual check of protective grills, checking VMI for an open Headlamp Grill, Front Turn Signal Lenses campaign, contacting CAC to add VIN to the campaign (if necessary).

**Warranty Information****Repair 1**

**Operation:** Check protective grills (02-7006).

Damage Code	Operation Number	Labor Time (hrs.)	Model Indicator(s)
82 910 01 8	02-7006	0.1	L1, L2, L3, L7

**Repair 2**

**Operation:** Check protective grills (02-7006).  
Remove headlamp protective grills from brush guard (02-7008).

Damage Code	Operation Number	Labor Time (hrs.)	Model Indicator(s)
82 910 01 8	02-7006	0.1	L1, L2, L3, L7
	02-7008	0.2	

**Repair 3**

**Operation:** Check protective grills (02-7006).  
 Remove headlamp protective grilles (**Includes:** Replace headlamp trim) (02-7010).  
 Paint headlamp trim.

Damage Code	Operation Number	Labor Time (hrs.)	Model Indicator(s)
82 910 01 7	02-7006	0.1	L1, L2, L3, L7
	02-7010	0.4	
	Submit as a SUBLET utilizing sublet code of SUB with required amount.		

**Repair 4**

**Operation:** Check protective grills (02-7006).  
 Replace turn signal lamp lenses (02-7012).

Damage Code	Operation Number	Labor Time (hrs.)	Model Indicator(s)
82 910 01 7	02-7006	0.1	L1, L2, L3, L7
	02-7012	0.2	

**Repair 5**

**Operation:** Check protective grills (02-7006).  
 Remove headlamp protective grills from brush guard (02-7008).  
 Replace turn signal lamp lenses (02-7012).

Damage Code	Operation Number	Labor Time (hrs.)	Model Indicator(s)
82 910 01 7	02-7006	0.1	L1, L2, L3, L7
	02-7008	0.2	
	02-7012	0.2	

**Repair 6**

**Operation:** Check protective grills (02-7006).  
 Remove headlamp protective grilles (**Includes:** Replace headlamp trim) (02-7010).  
 Paint headlamp trim.  
 Replace turn signal lamp lenses (02-7012).

Damage Code	Operation Number	Labor Time (hrs.)	Model Indicator(s)
82 910 01 7	02-7006	0.1	L1, L2, L3, L7
	02-7010	0.4	
	Submit as a SUBLET utilizing sublet code of SUB with required amount.		
	02-7012	0.2	

**NOTE REGARDING CUSTOMER REIMBURSEMENT**

Reimbursement to customers for repairs performed prior to this recall:

If the customer already paid to have this recall campaign condition repaired and provides adequate documentation to support their claim of a non-warranty repair of this item, they may be eligible to receive reimbursement.

Requests for reimbursement may include parts, labor, fees and taxes.

Reimbursement is limited to the amount the replacement of the front turn signal lenses and/or removal of head lamp grills would have cost if completed by an authorized Mercedes-Benz dealer under this campaign.

Submit a warranty claim, utilizing Damage Code 82 910 01 8 as a sublet, utilizing the sublet code of "SUB." Sublet repairs require dealer text as stated in the Warranty Policies and Procedures Manual. Repair date should be the date that the customer paid for the repair.

**Note:**

Please note the claim submitted for customer reimbursement will **not** close the campaign (if still open). If the customer is still in possession of the vehicle with an open campaign, please arrange to close the campaign in the usual manner as described in this bulletin.



Mercedes-Benz

Mercedes-Benz USA, LLC

Alan J. McLaren

Vice President  
Customer Services

**Safety Recall # 2010110008**  
**Mercedes-Benz Headlamp and Turn Signal Grills**

January, 2011

Dear Mercedes-Benz Owner,

This notice is sent to you in accordance with the requirements of the National Traffic and Motor Vehicle Safety Act.

Daimler AG (DAG), the manufacturer of Mercedes-Benz vehicles, has decided that certain model year 2002-2010 G-Class vehicles equipped with and dealer installed (accessory) headlamp and front fender turn signal grills fail to conform to the requirements of Federal Motor Vehicle Safety Standard (FMVSS) No. 108 S7.8.5, "Lamps, Reflective Devices, and Associated Equipment." Mercedes-Benz USA, LLC (MBUSA) therefore has initiated a recall of these vehicles. (Rear tail lamp grills are not affected by this recall). Our records indicate that your vehicle is included in the affected population of vehicles.

**WE SENT YOU THIS NOTICE BECAUSE WE ARE CONCERNED ABOUT YOUR SAFETY.**

The headlamps of the affected vehicles are equipped with a protective grill for protection of the headlamps during off-highway operation. FMVSS 108 S7.8.5 specifies that a grill shall not be installed in front of the lamp. The affected vehicles with the protective grills installed fail to meet all luminosity requirements of FMVSS 108 thereby increasing the risk of a crash. The affected vehicles may also be equipped with an allowable grill cover for front turn signal protection which also affects compliance with FMVSS 108 by reducing the turn signals' light visibility to other motorists.

MBUSA will conduct a recall campaign for the subject vehicles described above. The recall will be conducted to remove the headlamp grills and install improved turn signal units optimized for usage with front fender mounted grills (if installed). MBUSA will reimburse you for the cost of the removed headlamp grills.

An authorized Mercedes-Benz dealer is available to repair your vehicle to correct the situation described above. This service will be provided free of charge. The working time required is approximately one half hour. As a matter of normal service process, the authorized Mercedes-Benz dealer will also check for other repair measures which might be applicable to your vehicle and this may increase the required working time. Please contact an authorized Mercedes-Benz dealer for additional information and to schedule an appointment at your earliest convenience.

Please mention Recall Campaign #2010110008.

If you are no longer the vehicle owner, or have a change of address, please complete the reverse side of this letter and return the complete letter in the enclosed envelope. If this is a leased vehicle and the lessor and registered owner receive this notice, please forward this information by first class mail to the lessee. If you have paid to have this recall condition corrected prior to this notice you may be eligible to receive reimbursement. Please see the reverse side of this notice for details.

Please contact an authorized Mercedes-Benz dealer should you have any questions or encounter any difficulty regarding this recall. If a dealer is unable to remedy your situation please contact us at 1-(800) FOR-MERCEdes (1-800-367-6372).

If an authorized Mercedes-Benz dealer or Mercedes-Benz USA, LLC, fails or is unable to perform this service without charge within 60 days, pursuant to law 49 U.S.C. Chapter 301, you may submit a complaint to the Administrator, National Highway Traffic Safety Administration, 1200 New Jersey Avenue, S.E., Washington, D.C. 20590 or call the toll-free Auto Safety Hotline at 1-888-327-4236 (TTY 1-800-424-9153); or go to <http://www.safercar.gov>.

We apologize for any inconvenience this situation may cause you.

Sincerely,

Mercedes-Benz USA, LLC  
One Mercedes Drive  
P.O. Box 350  
Montvale, NJ 07645-0350  
Phone 1-800-FOR-MERCEdes (1-800-367-6372)  
Fax (201) 476-6211  
[www.MBUSA.com](http://www.MBUSA.com)



Mercedes-Benz - are registered trademarks of Daimler AG, Stuttgart, Germany

**IMPORTANT**

IF FOR ANY REASON YOU DO NOT NOW OWN THIS VEHICLE OR HAVE A CHANGE OF ADDRESS, PLEASE COMPLETE THE SECTION BELOW, PLACE IN THE ENCLOSED ENVELOPE, AND DROP IN ANY MAIL BOX. IF POSSIBLE, PROVIDE THE NAME AND ADDRESS OF THE PRESENT OWNER SO THAT WE MAY CONTACT THEM.

- SCRAPPED
- STOLEN
- OTHER \_\_\_\_\_
- SOLD \_\_\_\_\_ I HAVE SOLD THE VEHICLE TO: \_\_\_\_\_
- MY NEW ADDRESS IS: \_\_\_\_\_

NAME \_\_\_\_\_

STREET \_\_\_\_\_ APT. \_\_\_\_\_

CITY \_\_\_\_\_ STATE \_\_\_\_\_ ZIP \_\_\_\_\_

PHONE \_\_\_\_\_

THANK YOU FOR YOUR COOPERATION

\*\*\*\* PLEASE DO NOT DETACH. RETURN COMPLETE LETTER \*\*\*\*  
DO NOT USE THE ENCLOSED ENVELOPE FOR OTHER CORRESPONDENCE

**Reimbursement to Customers for Repairs Performed Prior to Recall**

If you have already paid to have this recall condition corrected you may be eligible to receive reimbursement.

Requests for reimbursement may include parts, labor, fees and taxes. Reimbursement may be limited to the amount the repair would have cost if completed by an authorized Mercedes-Benz dealer.

Please speak with your dealer concerning this matter.

**Affected Headlamp Grills and Turn Signal Grills**

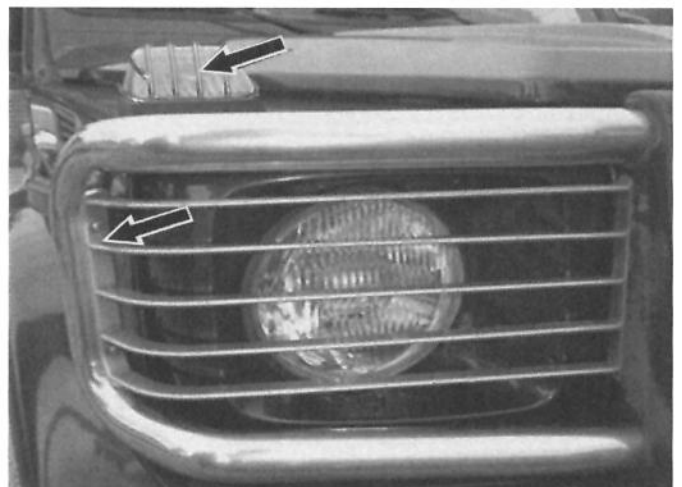
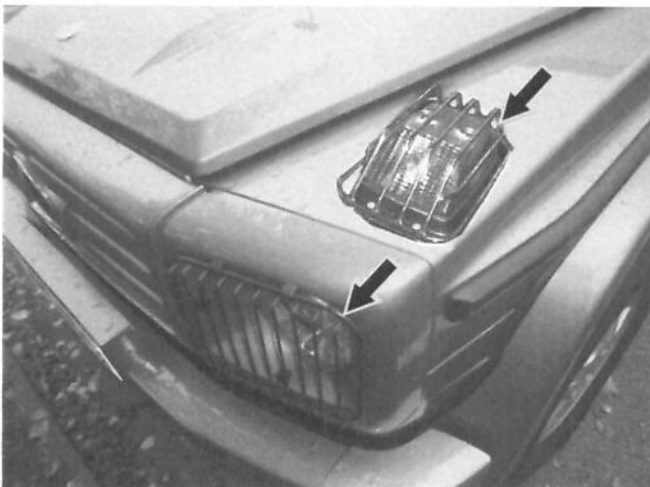

Please contact us at 1-(800) FOR-MERCEdes (1-800-367-6372) to be added to the recall campaign





Mercedes-Benz

Mercedes-Benz USA, LLC

Alan J. McLaren

Vice President  
Customer Services

**Safety Recall # 2010110008  
Mercedes-Benz Accessory Headlamp  
and Turn Signal Grills**

January, 2011

Dear Mercedes-Benz Owner,

This notice is sent to you in accordance with the requirements of the National Traffic and Motor Vehicle Safety Act.

Daimler AG (DAG), the manufacturer of Mercedes-Benz vehicles, has decided that certain model year 2002-2010 G-Class vehicles equipped with and dealer installed (accessory) headlamp and front fender turn signal grills fail to conform to the requirements of Federal Motor Vehicle Safety Standard (FMVSS) No. 108 S7.8.5, "Lamps, Reflective Devices, and Associated Equipment." Mercedes-Benz USA, LLC (MBUSA) therefore has initiated a recall of these vehicles. (Rear tail lamp grills are not affected by this recall). Our records indicate that your vehicle does not have factory equipped headlamp or front fender turn signal grills, **but that you may have purchased an accessory Mercedes-Benz headlamp or front fender mounted turn signal grill from an authorized Mercedes-Benz dealer.**

**WE SENT YOU THIS NOTICE BECAUSE WE ARE CONCERNED ABOUT YOUR SAFETY.**

The headlamps of the affected vehicles are equipped with a protective grill for protection of the headlamps during off-highway operation. FMVSS 108 S7.8.5 specifies that a grill shall not be installed in front of the lamp. The affected vehicles with the protective grills installed fail to meet all luminosity requirements of FMVSS 108 thereby increasing the risk of a crash. The affected vehicles may also be equipped with an allowable grill cover for front turn signal protection which also affects compliance with FMVSS 108 by reducing the turn signals' light visibility to other motorists.

**If your vehicle is equipped with a Mercedes-Benz accessory headlamp grill or front fender mounted turn signal grill (see reverse side for photo) please contact us at 1-(800) FOR-MERCEdes (1-800-367-6372) to be added to the recall campaign.**

**If your vehicle is not equipped with a Mercedes-Benz accessory headlamp grill or front fender mounted turn signal grill, it is not included in the recall and you may disregard this recall letter.**

MBUSA will conduct a recall campaign for the subject vehicles described above. The recall will be conducted to remove the headlamp grills and install improved turn signal units optimized for usage with front fender mounted grills (if installed). MBUSA will reimburse you for the cost of the removed headlamp grills.

An authorized Mercedes-Benz dealer is available to repair your vehicle to correct the situation described above. This service will be provided free of charge. The working time required is approximately one half hour. As a matter of normal service process, the authorized Mercedes-Benz dealer will also check for other repair measures which might be applicable to your vehicle and this may increase the required working time. Please contact an authorized Mercedes-Benz dealer for additional information and to schedule an appointment at your earliest convenience **after** you have called us at 1-(800) FOR-MERCEdes (1-800-367-6372) to be added to the recall campaign. Please mention Recall Campaign #2010110008.

If you are no longer the vehicle owner, or have a change of address, please complete the reverse side of this letter and return the complete letter in the enclosed envelope. If this is a leased vehicle and the lessor and registered owner receive this notice, please forward this information by first class mail to the lessee. If you have paid to have this recall condition corrected prior to this notice you may be eligible to receive reimbursement. Please see the reverse side of this notice for details.

Please contact an authorized Mercedes-Benz dealer should you have any questions or encounter any difficulty regarding this recall. If a dealer is unable to remedy your situation please contact us at 1-(800) FOR-MERCEdes (1-800-367-6372).

If an authorized Mercedes-Benz dealer or Mercedes-Benz USA, LLC, fails or is unable to perform this service without charge within 60 days, pursuant to law 49 U.S.C. Chapter 301, you may submit a complaint to the Administrator, National Highway Traffic Safety Administration, 1200 New Jersey Avenue, S.E., Washington, D.C. 20590 or call the toll-free Auto Safety Hotline at 1-888-327-4236 (TTY 1-800-424-9153); or go to <http://www.safercar.gov>.

We apologize for any inconvenience this situation may cause you.

Sincerely,

Mercedes-Benz USA, LLC  
One Mercedes Drive  
P.O. Box 350  
Montvale, NJ 07645-0350  
Phone 1-800-FOR-MERCEdes (1-800-367-6372)  
Fax (201) 476-6211  
[www.MBUSA.com](http://www.MBUSA.com)



Mercedes-Benz - are registered trademarks of Daimler AG, Stuttgart, Germany

**IMPORTANT**

IF FOR ANY REASON YOU DO NOT NOW OWN THIS VEHICLE OR HAVE A CHANGE OF ADDRESS, PLEASE COMPLETE THE SECTION BELOW, PLACE IN THE ENCLOSED ENVELOPE, AND DROP IN ANY MAIL BOX. IF POSSIBLE, PROVIDE THE NAME AND ADDRESS OF THE PRESENT OWNER SO THAT WE MAY CONTACT THEM.

- SCRAPPED
- STOLEN
- OTHER \_\_\_\_\_
- SOLD \_\_\_\_\_ I HAVE SOLD THE VEHICLE TO:
- MY NEW ADDRESS IS: \_\_\_\_\_

NAME \_\_\_\_\_

STREET \_\_\_\_\_ APT. \_\_\_\_\_

CITY \_\_\_\_\_ STATE \_\_\_\_\_ ZIP \_\_\_\_\_

PHONE \_\_\_\_\_

THANK YOU FOR YOUR COOPERATION

\*\*\*\* PLEASE DO NOT DETACH. RETURN COMPLETE LETTER \*\*\*\*  
DO NOT USE THE ENCLOSED ENVELOPE FOR OTHER CORRESPONDENCE

**Reimbursement to Customers for Repairs Performed Prior to Recall**

If you have already paid to have this recall condition corrected you may be eligible to receive reimbursement.

Requests for reimbursement may include parts, labor, fees and taxes. Reimbursement may be limited to the amount the repair would have cost if completed by an authorized Mercedes-Benz dealer.

Please speak with your dealer concerning this matter.

---

**Affected Headlamp Grills and Turn Signal Grills**

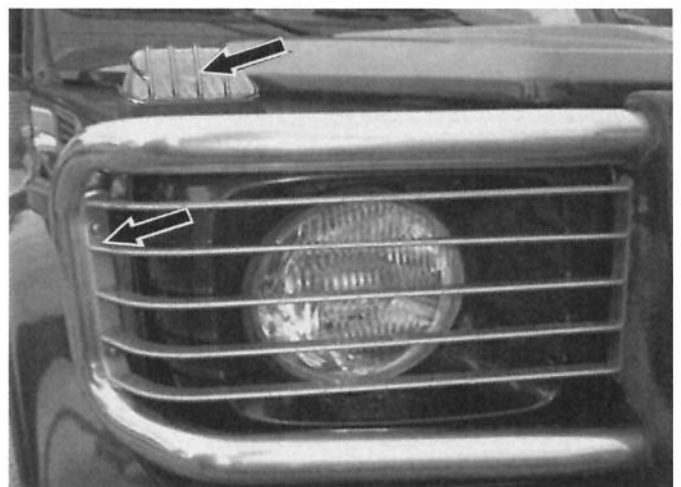
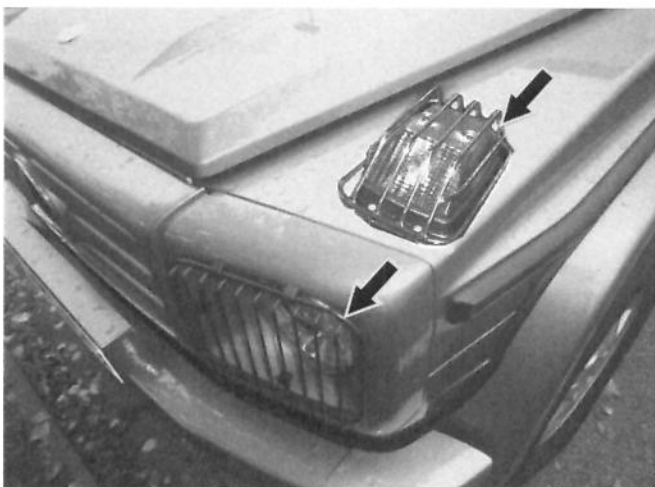

Please contact us at 1-(800) FOR-MERCEdes (1-800-367-6372) to be added to the recall campaign