



Install

Date: September 2002
Order No.: T-I-82.85/191
Supersedes:
Group: 82

**SUBJECT: MODEL 463.249
MODEL YEAR 2002
AUXILIARY INPUT HARNESS INSTALLATION (G-CLASS WITH COMAND)**

We are interested in your comments and/or suggestions regarding these installation instructions—please e-mail them to: technicalinformation@MBUSA.com

Note: Installation of the auxiliary input harness is not covered under warranty; it is a customer pay option.

1. Remove the glove compartment.
 - Refer to WIS: AR68.10-P-1400GM, "Remove/install glove compartment"
2. Measure and mark the glove compartment left side at the point where 80-mm (A, Figure 1) from the back edge and 30-mm (B, Figure 1) from the bottom edge meet.
3. Make an 18.8-mm hole at the measured mark (C, Figure 1).

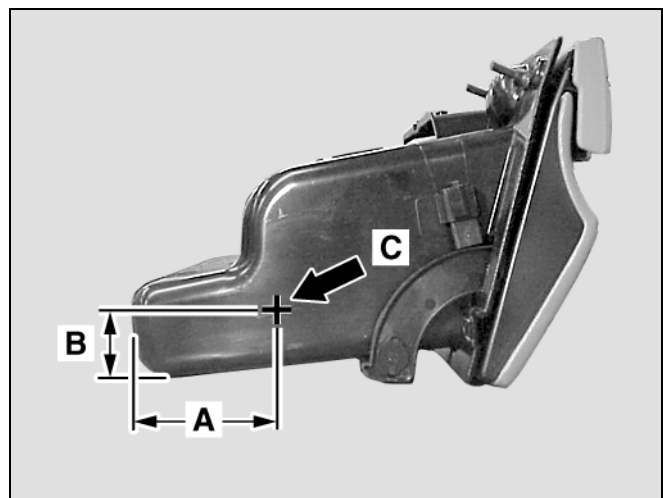

Figure 1

P82.85-9758-01

This bulletin has been created and maintained in accordance with MBUSA-SLP 5.1, Document and Data Control, and MBUSA-SLP 16.1, Control of Quality Records.

4. Remove the quick-release connector lock (A, Figure 2) from the auxiliary input harness connector (B, Figure 2).

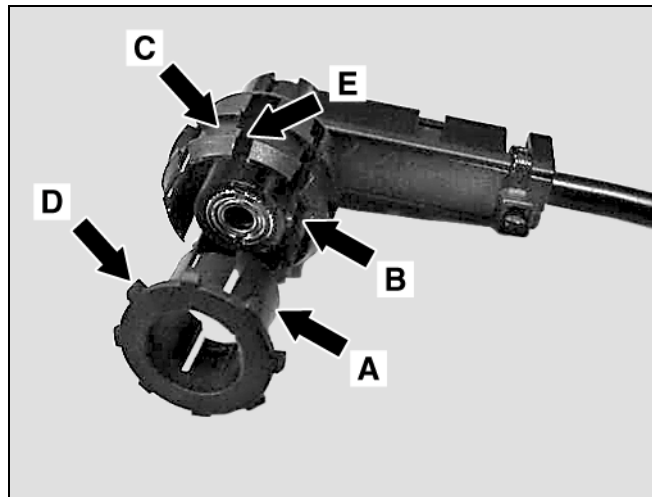

Figure 2

P82.85-9759-01

5. Insert the auxiliary input connector into the drilled hole from outside the glove compartment (Figure 3).

Note: Be sure the edge of the glove compartment hole inserts into the groove in the connector (C, Figure 2).

6. From inside the glove compartment, lock the connector in place by inserting the quick-release connector lock into the connector face.

Note: Be sure the spines (D, Figure 2) of the quick-release lock inserts into the corresponding notches (E, Figure 2) in the connector.

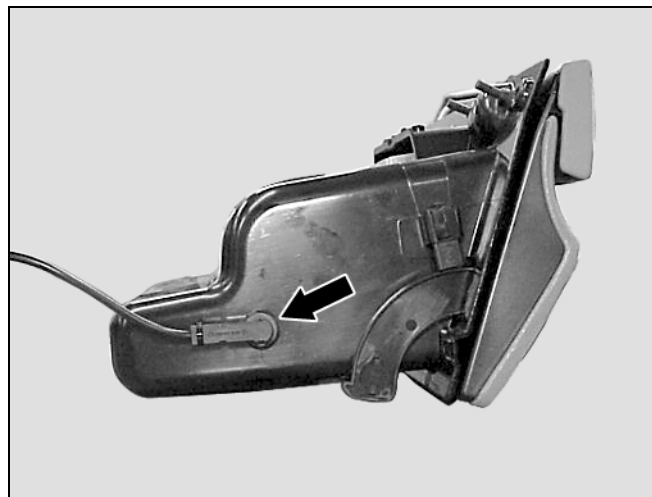

Figure 3

P82.85-9760-01

7. Clip off the terminals from the individual wires of the auxiliary input harness (Figure 4).



Figure 4

P82.85-9761-01

8. Install the new terminals (part number: A 008 545 55 26) to the auxiliary input harness wires using the appropriate tools from the wiring harness repair kit (part number 220 589 01 99 00) (Figure 5).
9. Remove the COMAND unit.
 - Refer to WIS: AR82.85-P-7472GM, "Removing and installing operating and display system with control module"

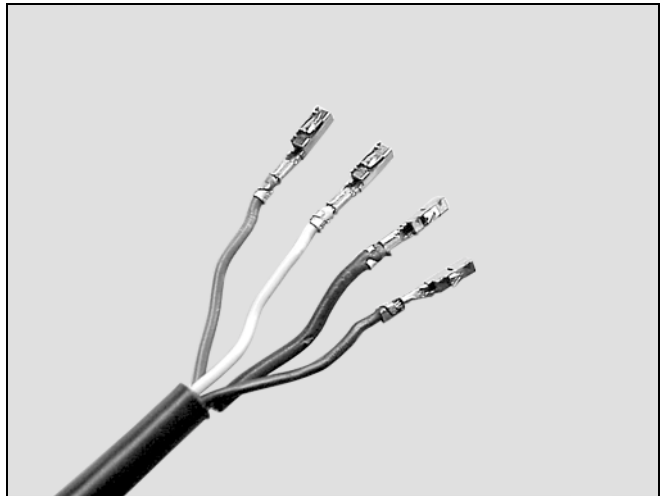

Figure 5

P82.85-9762-01

10. Position the glove compartment near its point of installation and feed the auxiliary input harness end through the glove compartment opening to the space vacated by the COMAND unit.
11. Reinstall the glove compartment.
 - Refer to WIS: AR68.10-P-1400GM, "Remove/install glove compartment"
12. Locate the disconnected C-2 plug in the space vacated by the COMAND unit (A, Figure 6).
13. Remove the pin connector from the C-2 plug (B, Figure 6 and Figure 7).

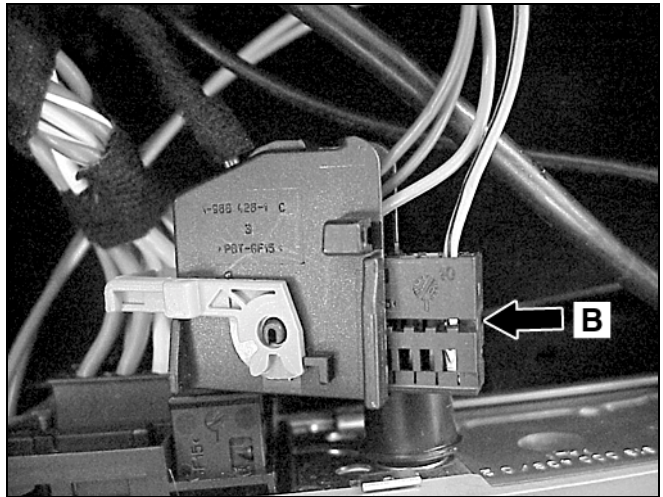

Figure 6

P82.85-9763-01

14. Connect the new terminals on the wires of the auxiliary input harness into the pin connector (A, Figure 7).
 - a) Thin-gauge black wire into pin-13 (A, Figure 8)
 - b) Thick-gauge black wire into pin-14 (B, Figure 8)
 - c) Yellow wire into pin-04 (C, Figure 8)
 - d) Brown wire into pin-05 (D, Figure 8)

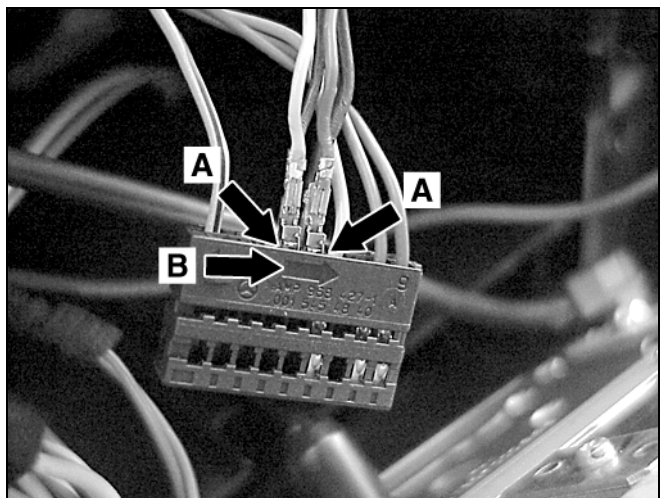

Figure 7

P82.85-9764-01

15. Reinsert the pin connector into the C-2 plug, making sure the arrow on the pin connector points toward the C-2 plug (B, Figure 7).
16. Reinstall the COMAND unit.
 - Refer to WIS: AR82.85-P-7472GM, "Removing and installing operating and display system with control module"
17. See page 225 of the COMAND Operator's Manual for instruction on switching on the auxiliary audio source.

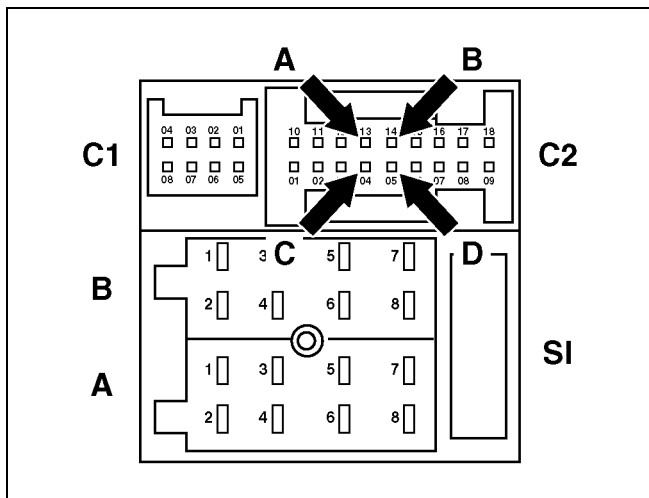

Figure 8

P82.85-9765-01

Parts Information

Qty.	Part Name	Part Number/Exchange
1	Auxiliary input harness	A 203 540 61 07
4	Terminals	A 008 545 55 26