

Test values and adjusting values - rear door

Number	Designation	Model 461, 463
BE72.12-P-1001-01A	Protrusion with door closed	mm 0.5 (-1)

- 1 Screw bolts into closing wedge (2) of rear-end door
 Do not yet tighten bolts.
- 2 Close and open rear-end door
- 3 Tighten bolts on closing wedge (2) of rear-end door
- 4 Close rear-end door and check protrusion of rear-end door
 If necessary, correct protrusion by moving closing wedge
- 5 Close rear-end door from inside
- 6 Knock locking lug (arrow) toward outside as far as possible from inside with hammer and wedge with rear-end door closed.
- 7 Open rear-end door and tighten bolts on closing wedge (2) and locking lug.

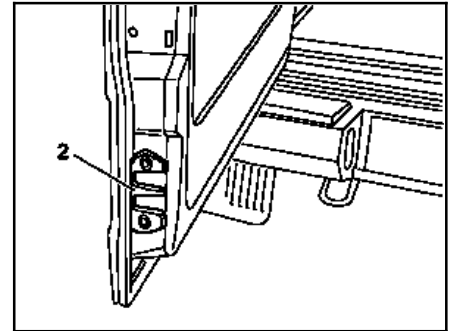

P72.20-0279-01

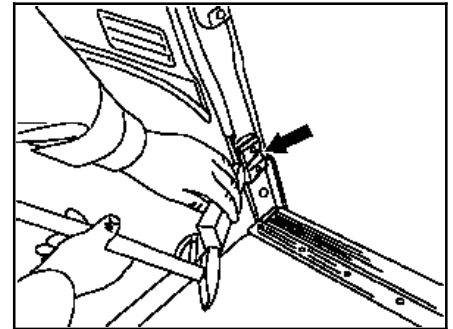

P72.20-0305-01