

Vorderachse, Hinterachse
Typ 461, 463

Bestell-Nr. 6510 5765 02

Printed in Germany

0400 0,03 ff

Contents

Chapter	Coordinates	Page
1 General		
Installation survey	B 1	1.1/1
Ratio	D 1	1.1/2
Capacities	D 1	1.1/2
Key to axle designation	D 1	1.1/2
Sectional view	E 1	1.2/1
Special tools	G 1	1.3/1
Tightening torques	K 1	1.4/1
Setting values	L 1	1.5/1
Expendable materials	M 1	1.5/1
Exploded view	N 1	1.6/1
2 Recondition front axle		
Removal and installation of front axle	G 2	2.1/1
Removal and installation of trailing arm	O 2	2.2/1
3 Check wheel bearing play, adjust		
4 Recondition wheel hub		
Removal and installation of wheel hub	K 3	4.1/1
Disassembly and assembly of wheel hub	E 4	4.2/1
5 Recondition joint housing		
Removal and installation of joint housing with drive shaft	H 4	5.1/1
Disassembly and assembly of joint housing	E 5	5.2/1
Removal and installation of drive shaft	K 5	5.3/1
Disassembly and assembly of drive shaft	A 6	5.4/1
Adjusting steering knuckle bearing, Type 461	E 6	5.5/1
Adjusting steering knuckle bearing, Type 463	K 6	5.6/1
6 Exchange sealing rings on bevel gear		
7 Recondition differential		
Removal and installation of differential	G 7	7.1/1
Disassembly and assembly of differential (with differential lock)	A 8	7.2/1
Disassembly and assembly of differential (without differential lock)	H 8	7.3/1
8 Removal and installation of bevel gear, recondition		
9 Recondition differential lock		
Removal and installation of differential lock	L 9	9.1/1
Disassembly and assembly of shift cylinder	A 10	9.2/1
Adjusting shift cylinder	G 10	9.3/1
10 Check concentricity of flange		
	H 10	10.1/1

Installation survey

Vehicle		Front axle		Brake	Version	Installation
Model	Sales designation	Model	Sales designation			
461.229 .238 .239 .249 .266 .267 .227	230 GE 4x4	730.311 .323	AL 0/1C-1,3/5,286 AL 0/1C-1,3/4,857 AL 0/1C -1,3/5,286	Disc brake	with differential lock (SA)	Standard SA
461.328 .337 .338 .341 .367 .368 .329	290 GE 4x4	730.312 .323	AL 0/1C -1,3/4,857 AL 0/1C -1,3/5,286 AL 0/1C -1,3/5,286			
463.200 .220 .221	200 GE 4x4 ³⁾	730.305	AL 0/3C -1,3/5,286		with differential lock ⁴⁾	Standard
463.204 .224 .225	230 GE 4x4	730.305	AL 0/3C -1,3/5,286 AL 0/3C -1,3/4,857			
463.207 .227 .228 .228	300 GE 4x4 500 GE V8 4x4 ⁵⁾	730.391	AL 0/3C -1,3/4,857 AL 0/3C -1,3/4,375 AL 0/3C -1,3/4,111 AL 0/3C -1,3/5,286 AL 0/3C -1,3/4,375		without differential lock	Standard SA SA SA
463.304 .324 .325	250 GD 4x4	730.305	AL 0/3C -1,3/5,286			
463.307 .327 .328	300 GD 4x4	730.305	AL 0/3C -1,3/5,286 AL 0/3C -1,3/4,111 ⁶⁾ AL 0/3C -1,3/4,375		Standard SA SA	
463.300 .320 .321	350 GD 4x4 Turbo	730.392	AL 0/3C -1,3/4,111			Standard

1) With tires 255/75R15, 7,00R16, 7,50R16

2) Special equipment with tires 205/75R16, 225/75R16 only for countries without EC/ECE regulations

3) Model, country-specific e.g. Italy

4) Special equipment for export vehicles

5) Special model

6) Installed as of 01. 91 in connection with automatic transmission 1.8/4.375

SA = Special equipment

Ratio Type 461

Axle model	Number of teeth		Ratio i	Installation
	Ring gear	Bevel gear		
730.311	37	7	5,286	Standard
	34	7	4,857	SA
.312	34	7	4,857	Standard
	37	7	5,286	1) 2)
.323	37	7	5,286	Standard

1) With tires 255/75R15, 7,00R16, 7,50R16

2) Special equipment with tires 205/75R16, 225/75R16 only for countries without EC/ECE regulations

SA = Special equipment

Ratio Type 463

Axle model	Number of teeth		Ratio i	Installation
	Ring gear	Bevel gear		
730.305	37	7	5,286	Standard
	37	9	4,111	SA
	35	8	4,375	SA
	34	7	4,857	SA
730.391	34	7	4,857	Standard
	37	9	4,111	SA
	37	7	5,286	SA
	35	8	4,375	SA
.392	37	9	4,111	Standard

SA = Special equipment

Capacity

Service product (Sheet No. of MB Service Product Specifications)	SAE grade	Capacity (l)	
		Type 461	Type 463
Gear oil	90,85 W 90	1,4	1,1

Key to axle designation

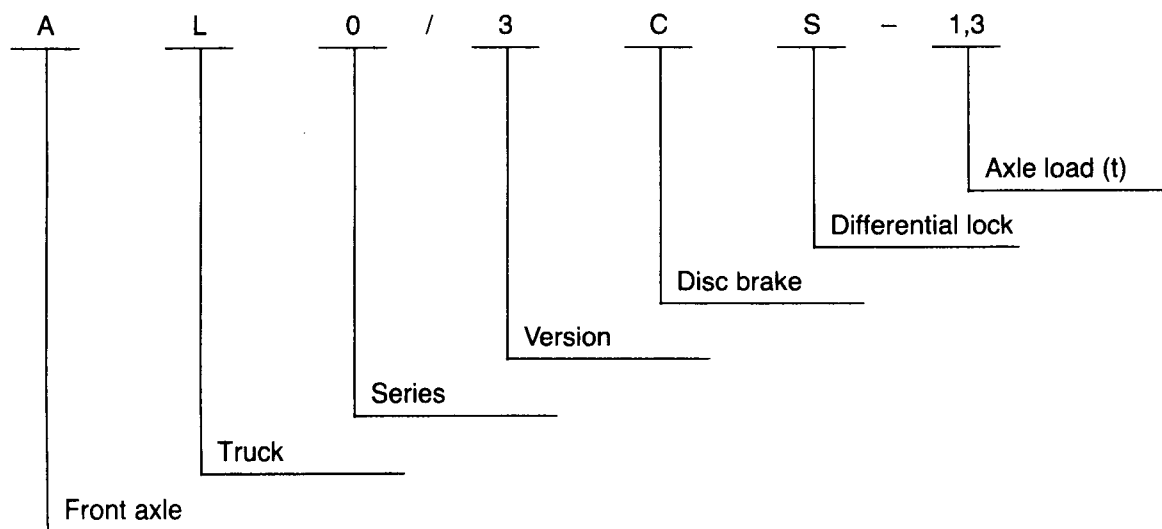

Sectional view

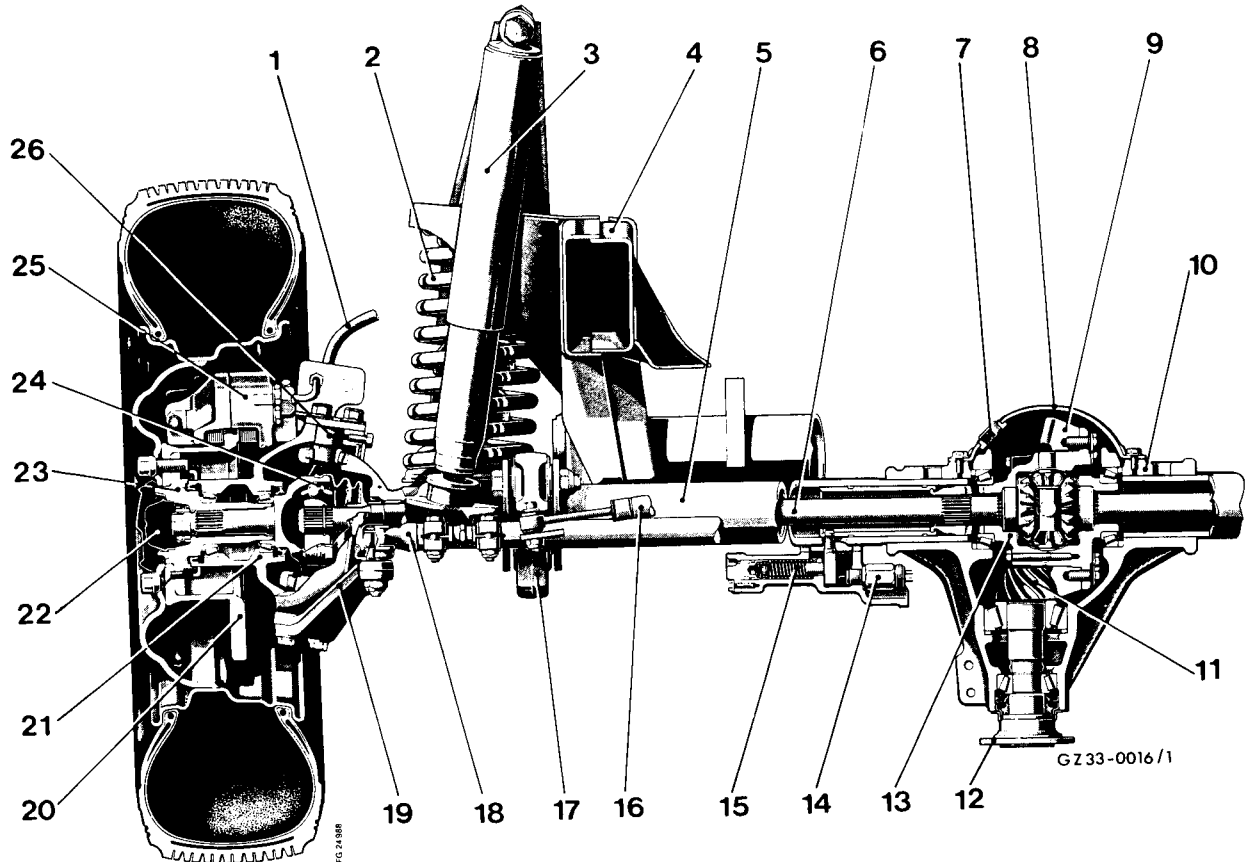

Front axle

- | | | | | | |
|----|----------------------------|----|--------------------------------------|----|-------------------------------------|
| 1 | Brake lines | 11 | Drive pinion | 20 | Brake disc |
| 2 | Helical spring | 12 | Drive flange | 21 | Joint housing |
| 3 | Shock absorber | 13 | Differential housing | 22 | Grease cap |
| 4 | Frame | 14 | Switch for indicator lamp | 23 | Wheel hub |
| 5 | Axle tube | 15 | Slave cylinder for differential lock | 24 | Drive shaft constant velocity joint |
| 6 | Input shaft | 16 | Steering shock absorber | 25 | Fixed caliper |
| 7 | Oil filter screw | 17 | Trailing arm | 26 | Kingpin |
| 8 | Differential housing cover | 18 | Tie rod | | |
| 9 | Ring gear | 19 | Steering arm | | |
| 10 | Axle housing | | | | |

Differential lock

- a = Axle housing ventilation
 b = Shift finger

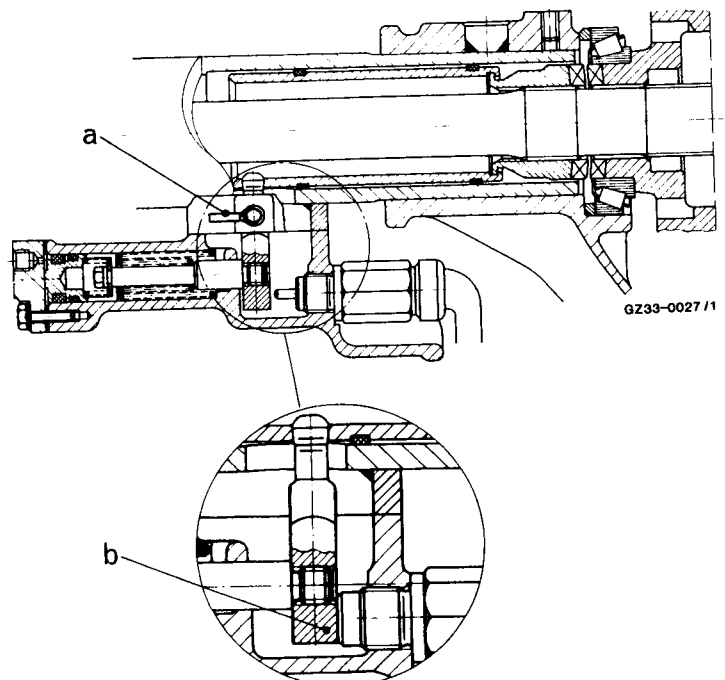

Special tools 

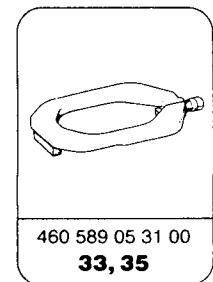
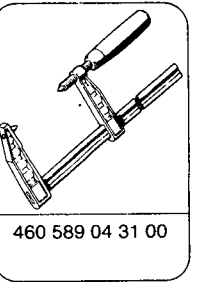
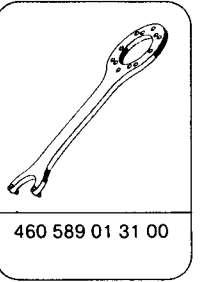
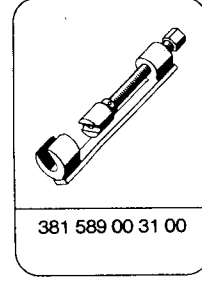
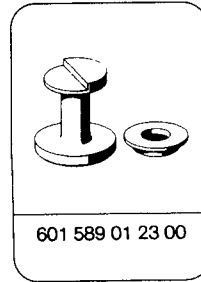
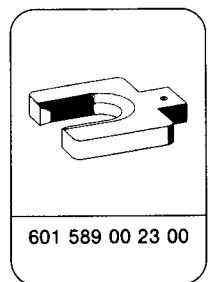
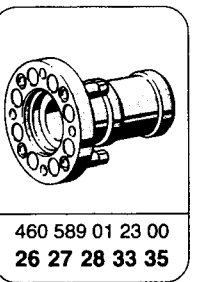
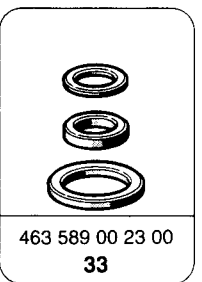
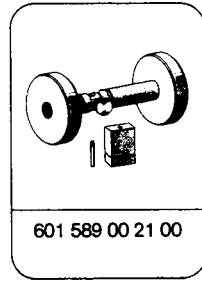
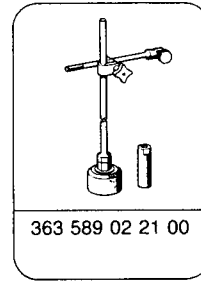
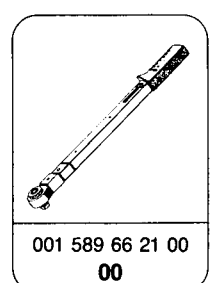
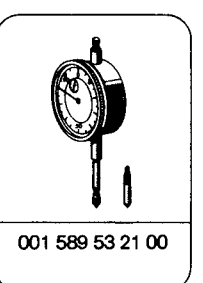
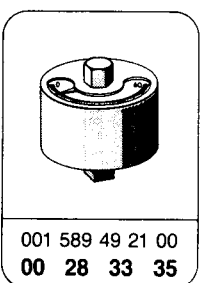
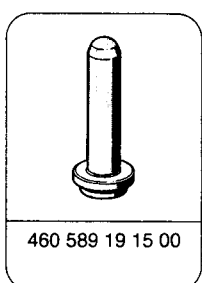
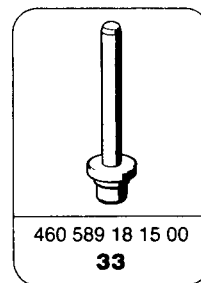
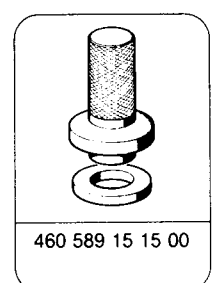
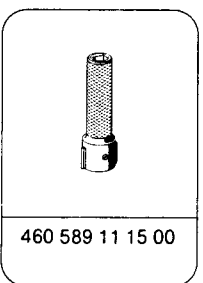
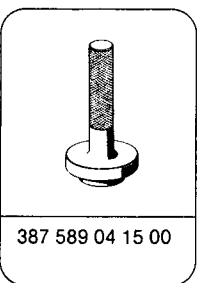
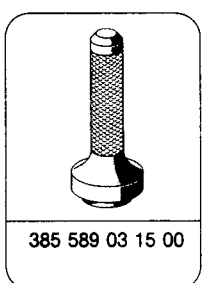
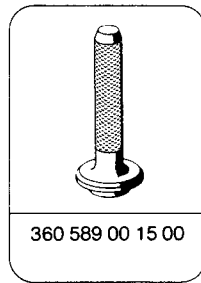
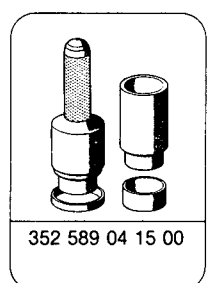
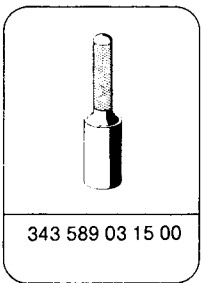
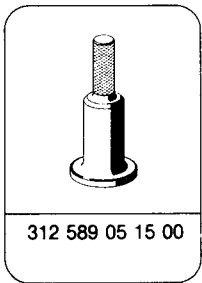
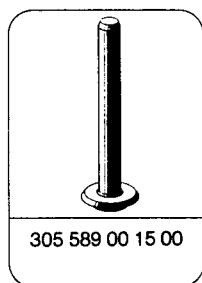
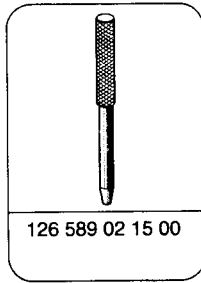
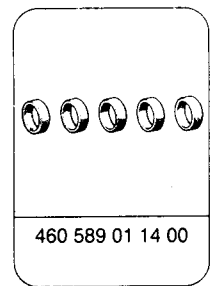
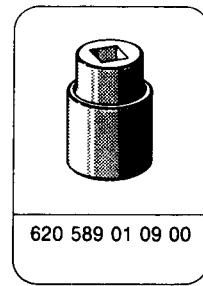
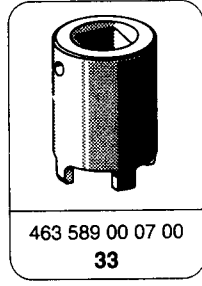
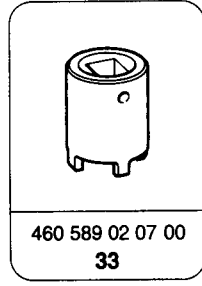
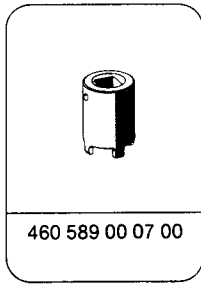

Special tools 

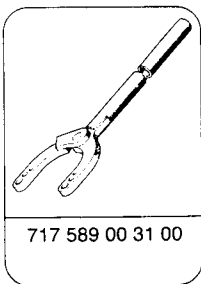

717 589 00 31 00

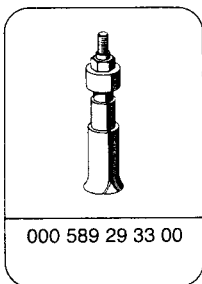

000 589 29 33 00

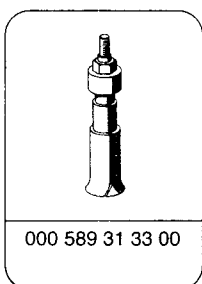

000 589 31 33 00

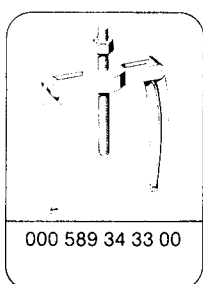

000 589 34 33 00

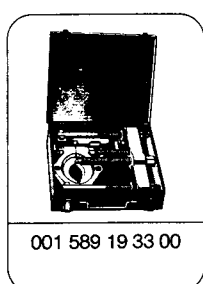

001 589 19 33 00

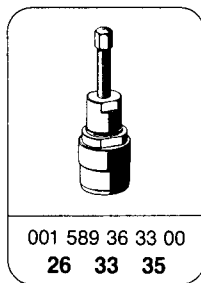

001 589 36 33 00
26 33 35

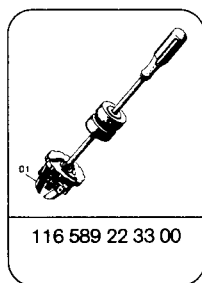

116 589 22 33 00

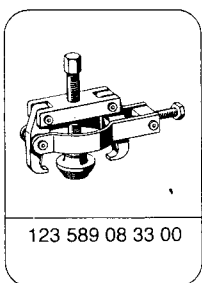

123 589 08 33 00

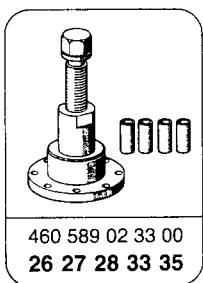

460 589 02 33 00
26 27 28 33 35

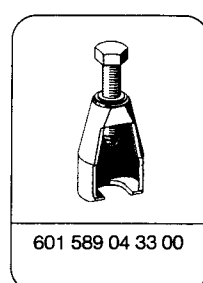

601 589 04 33 00

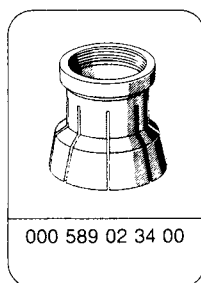

000 589 02 34 00

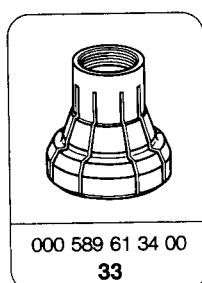

000 589 61 34 00
33

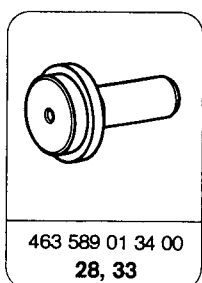

463 589 01 34 00
28, 33

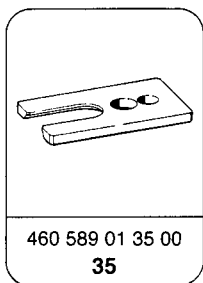

460 589 01 35 00
35

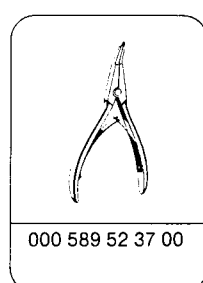

000 589 52 37 00

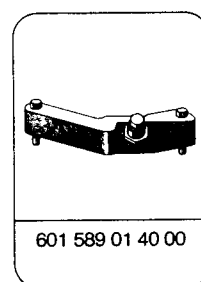

601 589 01 40 00

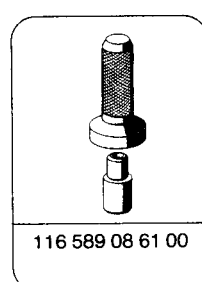

116 589 08 61 00

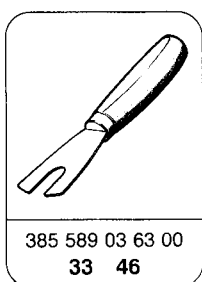

385 589 03 63 00
33 46

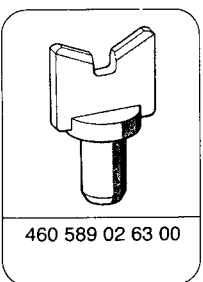

460 589 02 63 00

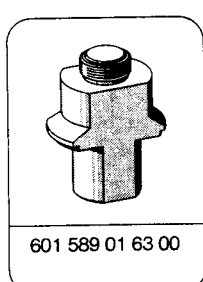

601 589 01 63 00

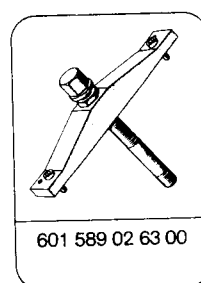

601 589 02 63 00

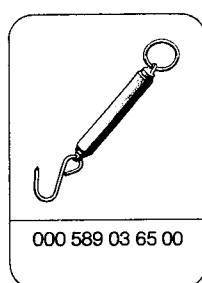

000 589 03 65 00

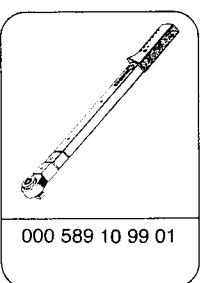

000 589 10 99 01

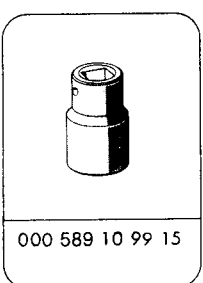

000 589 10 99 15

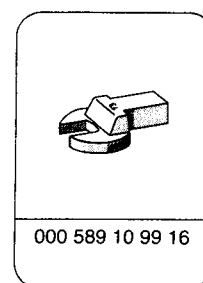

000 589 10 99 16

Tightening torques

Designation	Thread	Nm
Wheel mounting bolts	(at steel rim)	180
	(to light alloy rim)	130
Drag link to steering arm	M 16 x 1,5	120 to 140
Stabilizer to bracket	M 12 8.8	70
Shock absorber to front axle	M 14 x 1,5 – 8.8	70
Transverse link to frame	M 16 x 1,5 – 8.8	210
Trailing arm to frame	M 16 x 1,5 – 8.8	130
Gasket retainer to joint housing	M 8 8.8	20 to 25
Steering shock absorber bracket to axle housing or tie rod ¹⁾	M 10 8.8	45 to 50
	M 8 8.8	23 to 27
Cover to axle housing	M 8 10.9	60 to 70
Bearing cap to axle housing	M 10 10.9	65 to 75
Cover to differential housing	M 8 10.9	40 to 45
Shift lever to shifter shaft	M 10 x 1,25	20 to 25
Shift cylinder to axle tube	M 8 8.8	22 to 25
Pressure switch to shift cylinder	(Initial torque)	10 to 20
	(Final torque)	95 to 105
Ring gear to differential housing	M 12 x 1 – 12.9	170 to 190
Kingpin to joint housing	M 14 x 1,5 – 12.9	170 to 190
Steering knuckle arm or steering arm to joint housing	M 14 x 1,5 – 12.9	250 to 280
Tie rod to steering arm	M 16 x 1,5 – ²⁾	120 to 140
Fixed caliper to joint housing	M 14 x 1,5 – 10.9	190 to 220
	M 16 x 1,5 – 10.9	250 to 280
Universal-joint drive shaft to flange	M 8 x 1,0	30 to 35

1) Clamp steering damper at 20° left-hand lock

2) Lower nut (04.2 hardness)

Workshop installation

Lever gauge

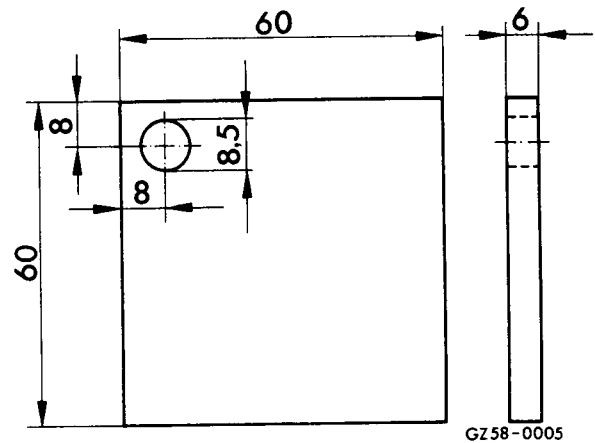
e.g. Hahn & Kolb
Tesastast DIN 2270**Tool for self-assembly**Base plate for measuring stand
Material: St. 37**Setting values**

Backlash	mm	0,10 to 0,15
Friction coefficient between drive pinion and radial seal	Nm	2,5 to 3,0
Friction torque for turning complete differential	Nm	20,0 to 40,0
Permissible wheel bearing clearance	mm	0,01 to 0,03 ¹⁾
Preload on the kingpins	mm	0,3 ± 0,05
Activating distance of lock in slave cylinder	mm	8 to 10

1) With used bearings aim for wheel bearing clearance of 0,03 mm.

Test values

Overall concentricity deviation of flange	mm	max. 0,07
-------------------------------------------	----	-----------

Expendable materials

Cons. No.	Designation	Part Number
1	Lubricant: Molycote	000 989 63 51
2	Sealing compound: Omnifit FD 10	002 989 00 20 10
3	Lubricant: multipurpose grease	commercially
4	Lubricant: Silicone-based grease	000 989 62 51
5	Locking agent: Loctite 241	002 989 94 71

Exploded view

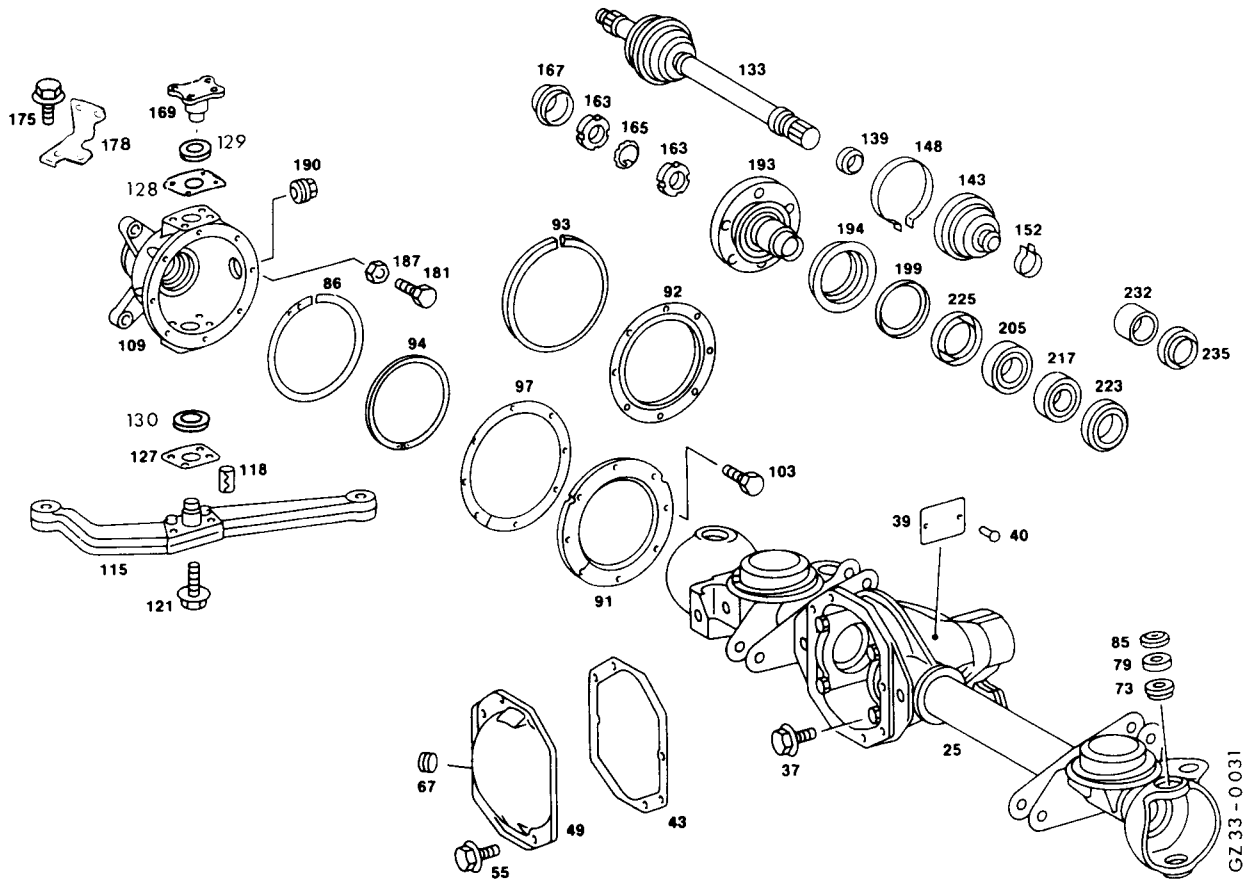

Front axle

- | | | | |
|-----|----------------------------------------------------------------------------------------------------|-----|------------------------|
| 25 | Axle housing | 133 | Drive shaft |
| 43 | Gasket | 139 | Bearig race |
| 49 | Cover axle housing | 143 | Gaiter |
| 67 | Screw plug | 148 | Compressor interior |
| 73 | Cap | 152 | Compressor outside |
| 79 | Tapered roller bearing | 163 | Nut |
| 85 | Sealing ring | 165 | Retainer |
| 91 | Sealing ring retainer outside | 167 | Grease cap |
| 92 | Bracket | 169 | Kingpin |
| 93 | Gasket | 178 | Bracket |
| 94 | Gasket | 190 | Screw plug |
| 109 | Housing | 193 | Front wheel hub |
| 115 | Track rod arm | 194 | Cover |
| 118 | Dowel pin | 199 | Sealing ring |
| 127 | Shim (Type 461 valid to vehicle ident. no. H048583) | 205 | Tapered roller bearing |
| 128 | Shim (Type 461 from start of production) | 217 | Tapered roller bearing |
| 129 | Fitted washer (Type 463 from start of production) | 223 | Sealing ring |
| 130 | Fitted washer (Type 461 valid from vehicle ident. no. H048584) (Type 463 from start of production) | 225 | Sealing ring |
| | | 232 | Bushing |
| | | 235 | Sealing ring |

Exploded view

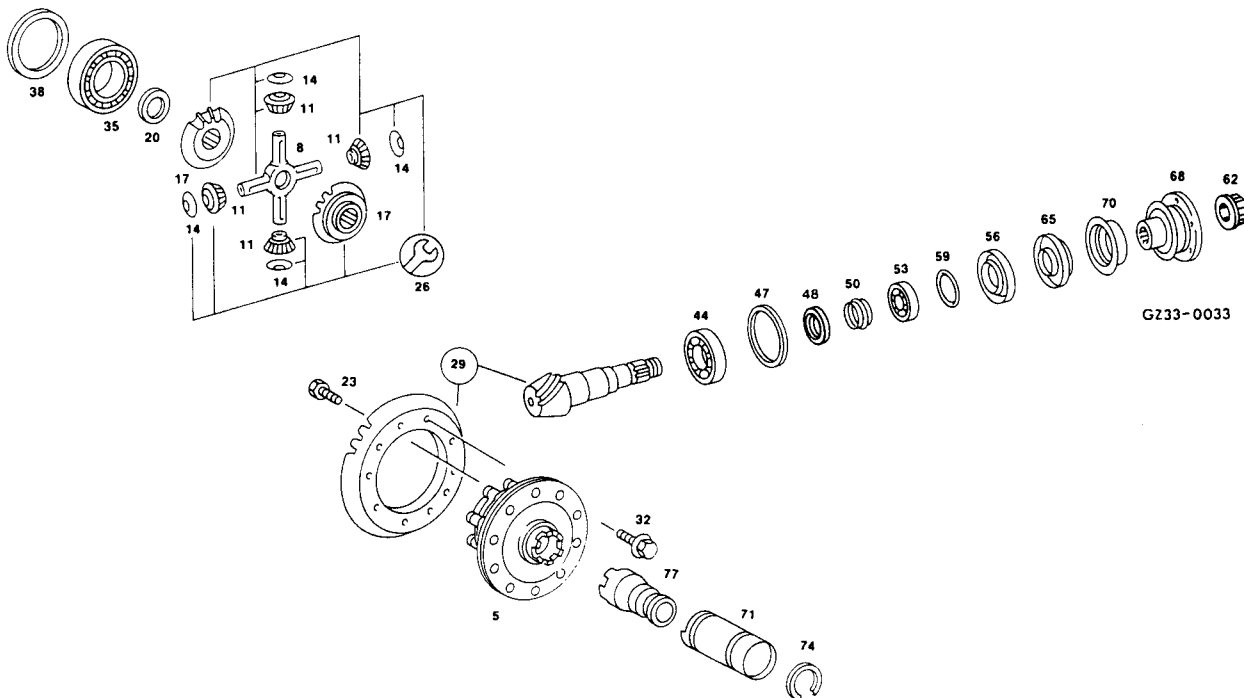

Differential and ring gear and pinion (with differential lock)

- | | | | |
|----|---------------------------|----|----------------------------|
| 5 | Differential | 48 | Ring |
| 8 | Differential spider | 50 | Support ring |
| 11 | Differential planet wheel | 53 | Tapered roller bearing |
| 14 | Spherical washer | 59 | Sealing ring |
| 17 | Side gear | 62 | Nut |
| 20 | Thrust washer | 65 | Sealing ring |
| 26 | Repair kit, differential | 68 | Flange |
| 29 | Ring gear and pinion | 70 | Guard |
| 35 | Tapered roller bearing | 71 | Pipe for differential lock |
| 38 | Shim | 74 | Sliding piece |
| 44 | Tapered roller bearing | 77 | Driver |
| 47 | Shim | | |

Exploded view

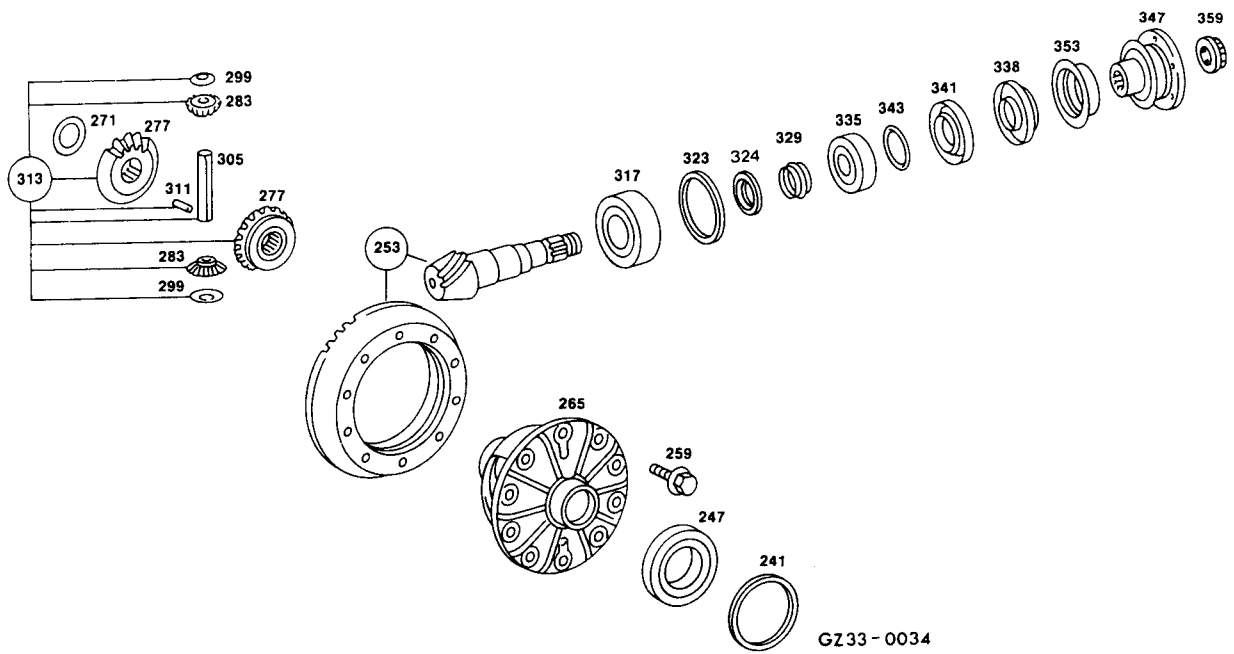

GZ33-0034

Differential and ring gear and pinion (without differential lock)

241	Shim	313	Repair set
247	Tapered roller bearing	317	Tapered roller bearing
253	Ring gear and pinion	323	Shim
259	Screw	324	Ring
265	Differential	329	Distance sleeve
271	Thrust washer	335	Tapered roller bearing
271	Side gear	341	Sealing ring
283	Differential planet wheel	347	Flange
299	Thrust ring	353	Guard
305	Pin	359	Nut
311	Clamping sleeve		

Exploded view

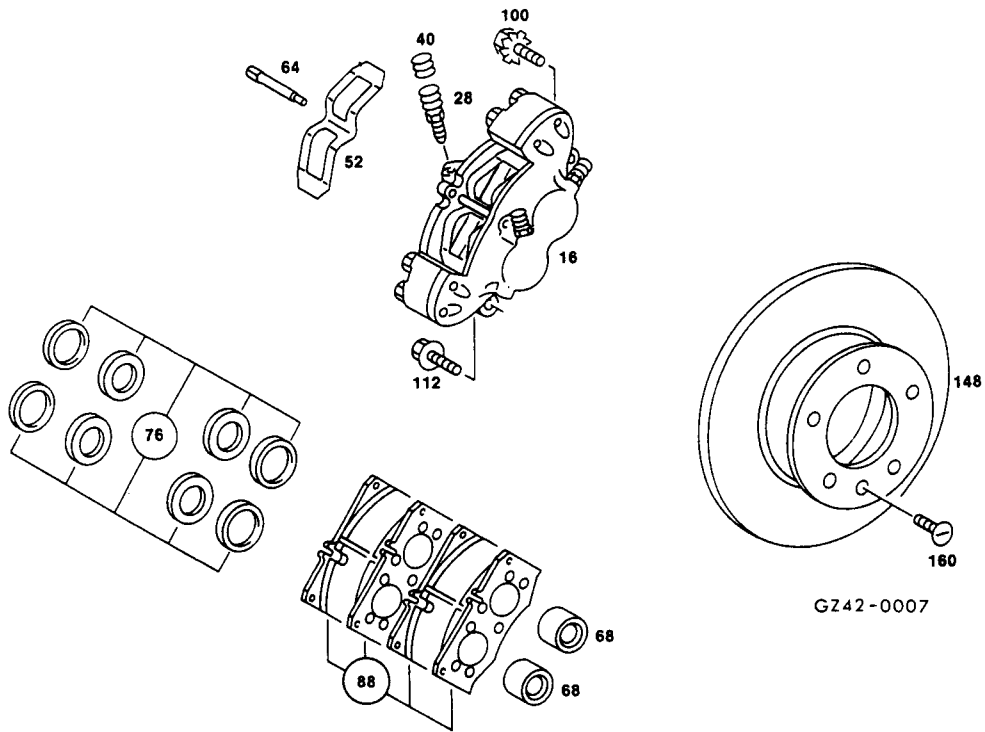

Fixed caliper, front axle

- | | | | |
|----|---------------------|-----|-----------------------|
| 16 | Fixed caliper | 88 | Repair kit, brake pad |
| 52 | Spring | 100 | Locking screw |
| 64 | Retaining pin | 112 | Fitted bolt |
| 68 | Piston | 148 | Brake disc |
| 76 | Repair kit, gaskets | | |

Exploded view

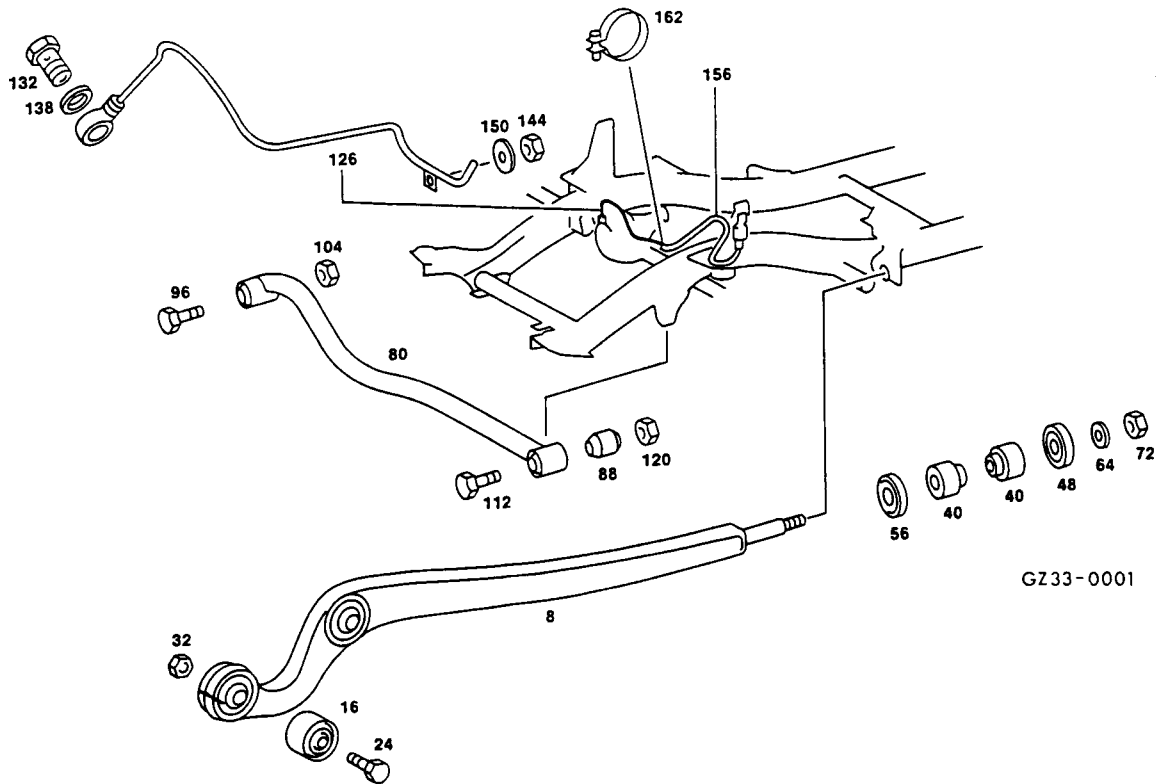

Trailing arm

- | | | | |
|----|-----------------|-----|--------------|
| 8 | Radius arm | 96 | Screw |
| 16 | Bearing | 104 | Nut |
| 24 | Screw | 112 | Screw |
| 32 | Nut | 120 | Nut |
| 40 | Rubber mount | 126 | Line |
| 48 | Washer | 132 | Hollow screw |
| 56 | Washer | 138 | Gasket |
| 64 | Washer | 144 | Nut |
| 72 | Nut | 150 | Washer |
| 80 | Transverse link | 156 | Hose |
| 88 | Bushing | 162 | Clamp |

Exploded view

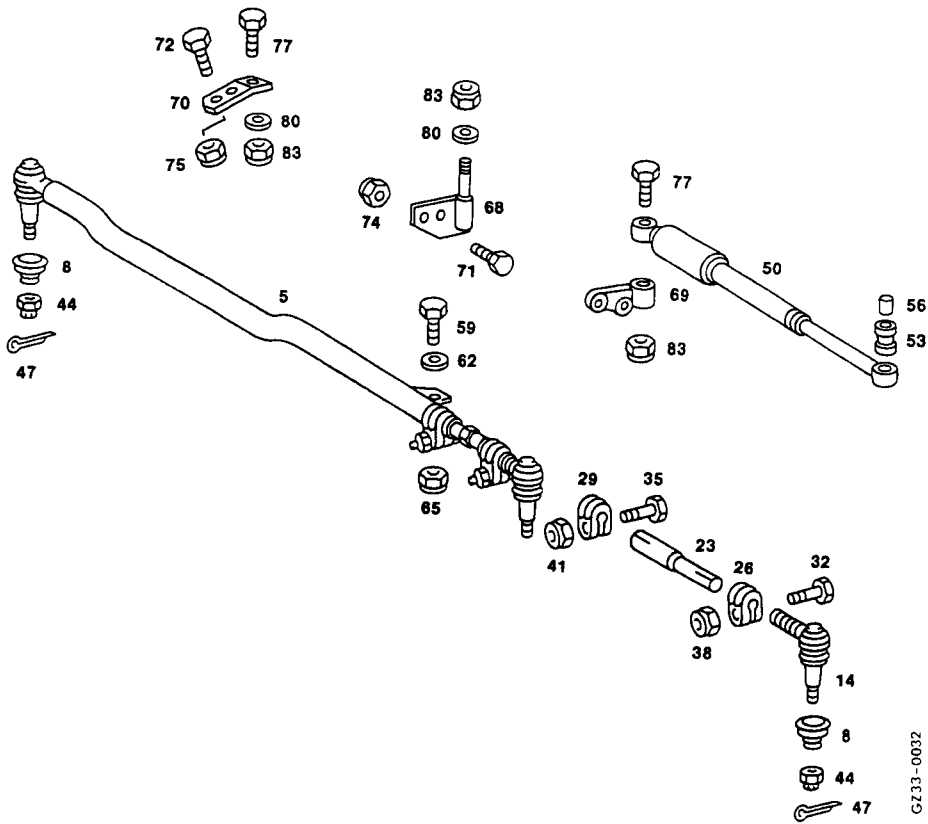

Tie rod

- | | | | |
|----|----------------|----|---------|
| 5 | Tie rod | 56 | Bushing |
| 8 | Gaiter | 59 | Screw |
| 14 | Joint | 62 | Washer |
| 23 | Clamping piece | 65 | Nut |
| 26 | Clamp | 68 | Bracket |
| 29 | Clamp | 69 | Bracket |
| 32 | Screw | 70 | Bracket |
| 35 | Screw | 71 | Screw |
| 38 | Nut | 72 | Screw |
| 41 | Nut | 74 | Nut |
| 44 | Nut | 75 | Nut |
| 47 | Cotter pin | 77 | Screw |
| 50 | Shock absorber | 80 | Washer |
| 53 | Rubber ring | 83 | Nut |

Special tools 

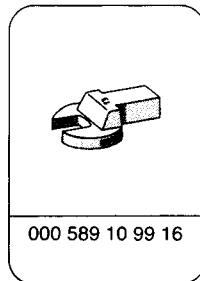
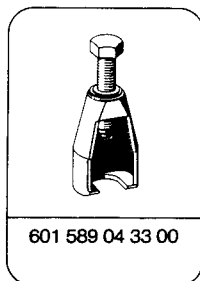
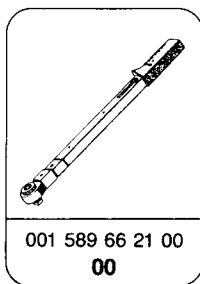

Capacities

Service product (Sheet No. of MB Service Product Specifications)	SAE grade	Capacity (l)
Gear oil	90, 85 W 90	1,4

Front axle – Tightening torques

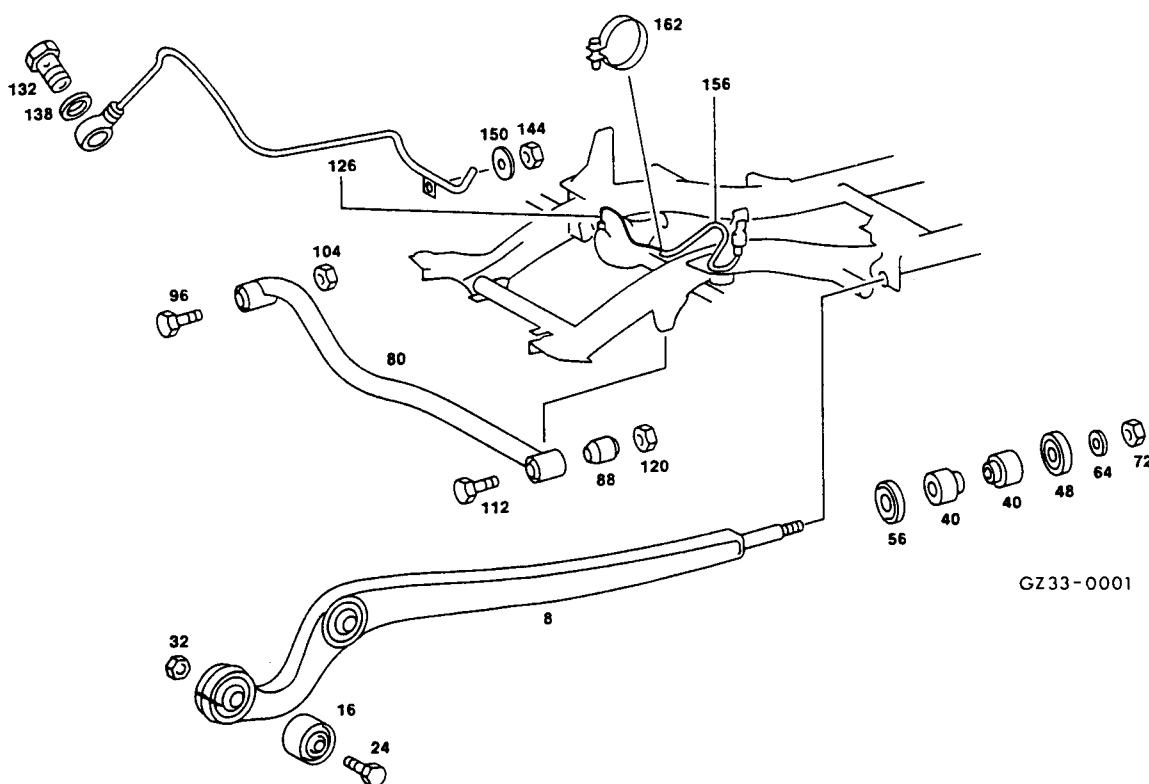
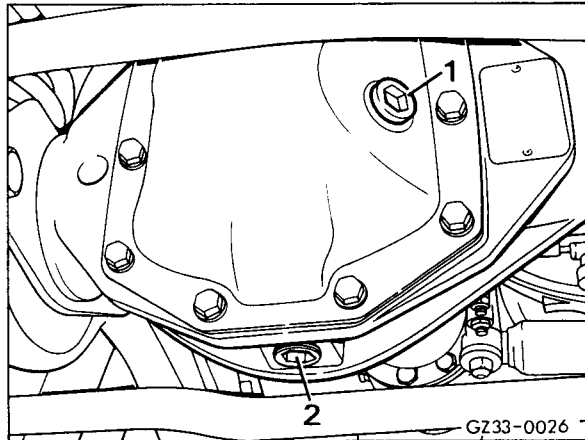

Fig. no.	Designation	Thread	Nm
72	Trailing arm to frame	M 16 x 1,5 – 8.8	130
112/120	Transverse link to frame	M 16 x 1,5 – 8.8	210
–	Tie rod to steering arm	M 16 x 1,5 – 1)	120 to 140
–	Drag link to steering arm	M 16 x 1,5 – 8.8	120 to 140
–	Stabilizer to bracket	M 12 x 60 – 8.8	70
–	Shock absorber to front axle	M 14 x 1,5 – 8.8	70
–	Wheel mounting bolts (at steel rim)	M 14 x 1,5 – 10.9	190
–	Universal-joint drive shaft to flange	M 8 x 1,0 x 22	30 to 35

1) Lower nut (04.2 hardness)

Removal

- 1 Secure vehicle against rolling away.
- 2 Drain oil (2) and collect.



- 3 Unscrew universal-joint drive shaft.
- 4 Tie universal-joint drive shaft to frame.

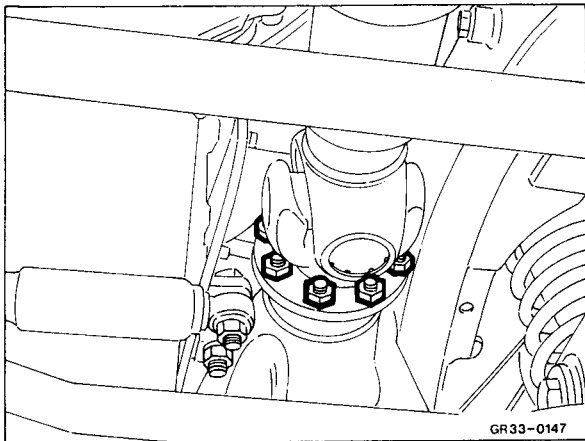

- 5 Unscrew shock absorber at axle.

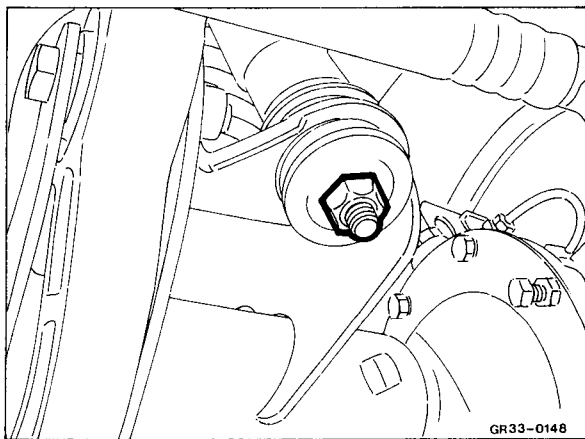

- 6 Loosen transverse link on the frame **only**.

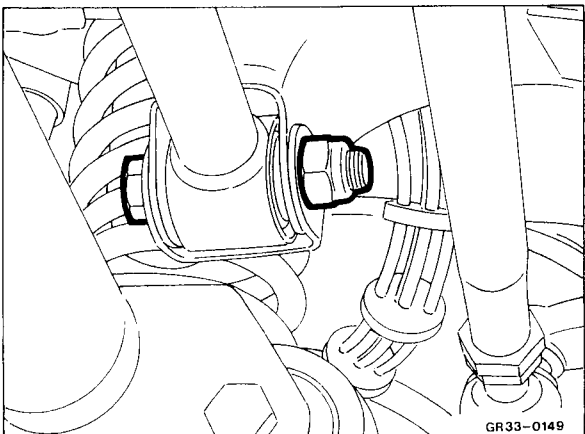

7 Unscrew and seal brake lines.

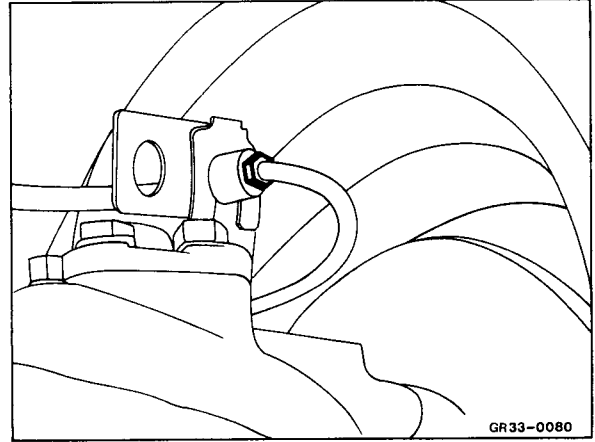

8 Unscrew stabilizer.

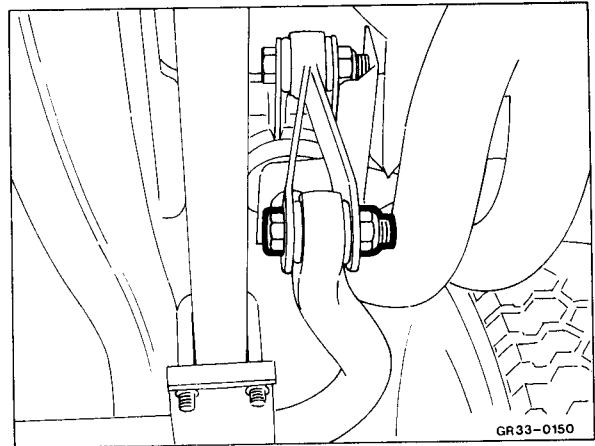

9 Release and unscrew castle nut on drag link.

10 Press drag link off steering arm.

 601 589 04 33 00

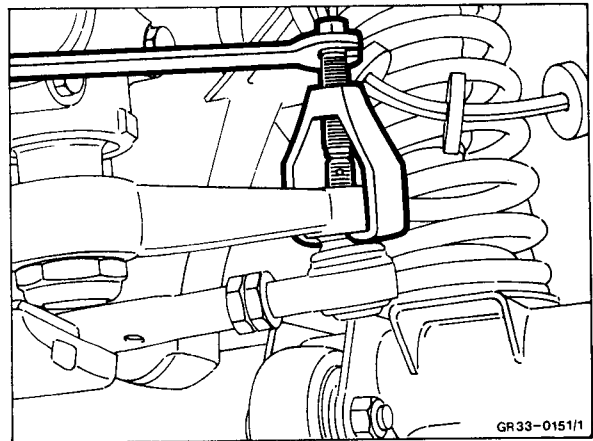

11 Unscrew trailing arm from frame.

12 Raise vehicle high enough to remove the springs.

13 Remove bolt on transverse link and remove front axle toward front.

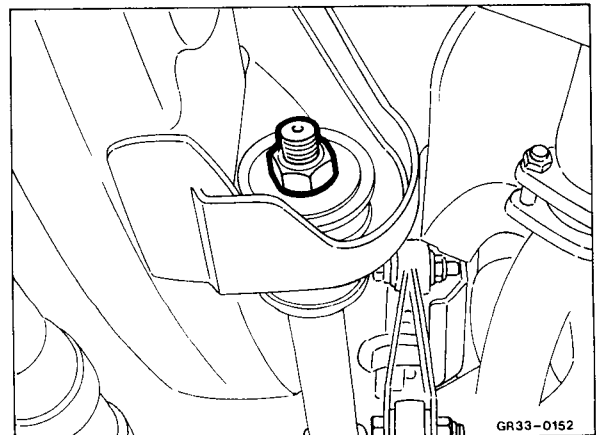

Installation

- 1 Insert front axle from front.
- 2 Install springs.
- 3 Install bolt in transverse link.
- 4 Lower vehicle until the trailing arms can be inserted into the frame.
- 5 Install rubber mounts, tighten nuts to 130 Nm.

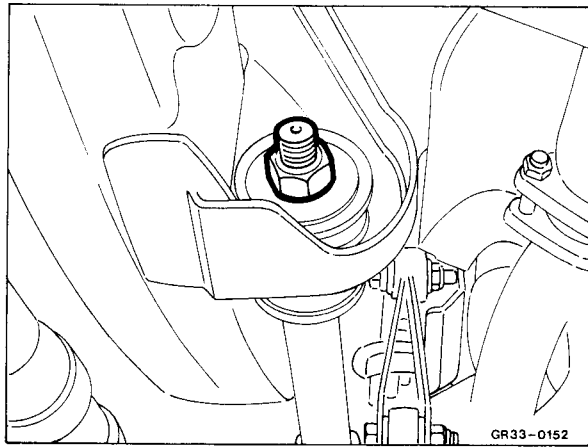

- 6 Install shock absorbers, tighten bolt to 70 Nm.

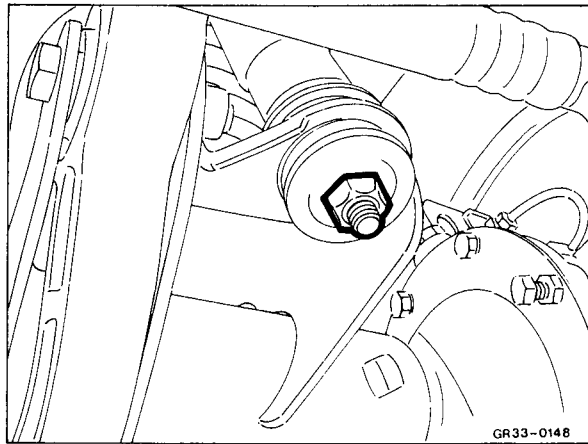

- 7 Tighten bolt on stabilizer to 70 Nm.

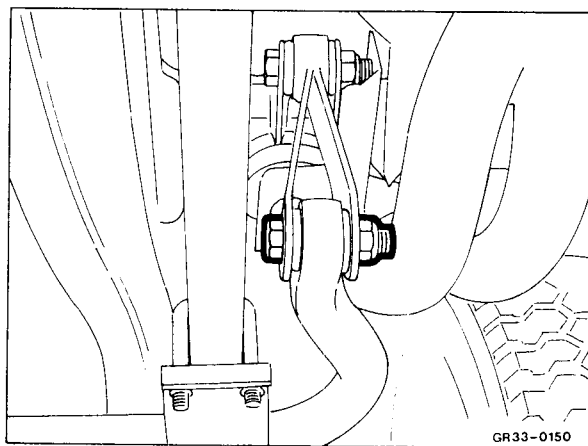

- 8 Tighten bolt on transverse link to 210 Nm.

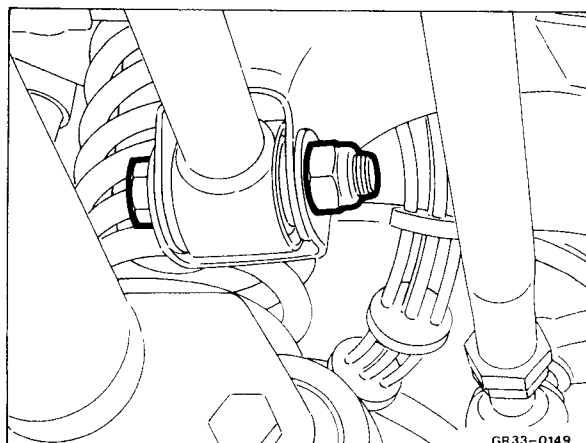

9 Bolt on drag link and tighten to 120 to 140 Nm, secure castle nut with cotter pin.

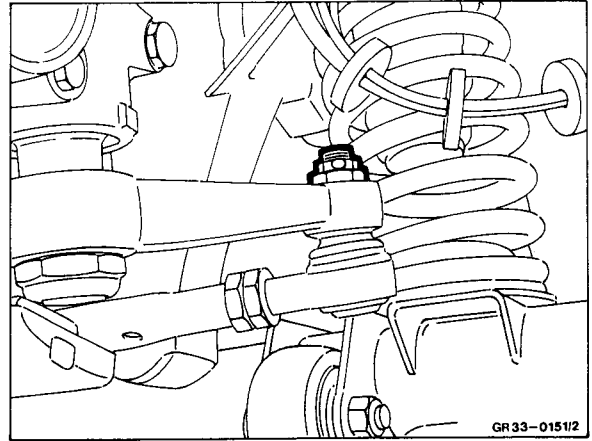

10 Attach brake line.

Note: In every wheel position a minimum clearance of 20 mm should be present between the springs and brake lines.

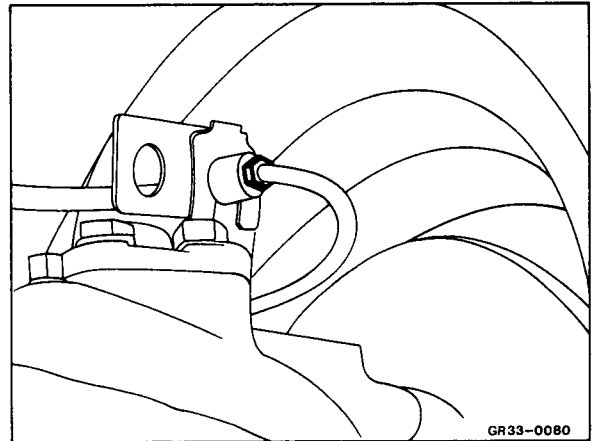

11 Install universal-joint drive shaft, tighten bolt to 30... 35 Nm.

Note: Use new self-locking nuts.

 000 589 10 99 16
001 589 66 21 00

12 Fill front axle housing with oil. Assure that proper type of oil is used.

Capacity 1,1 l

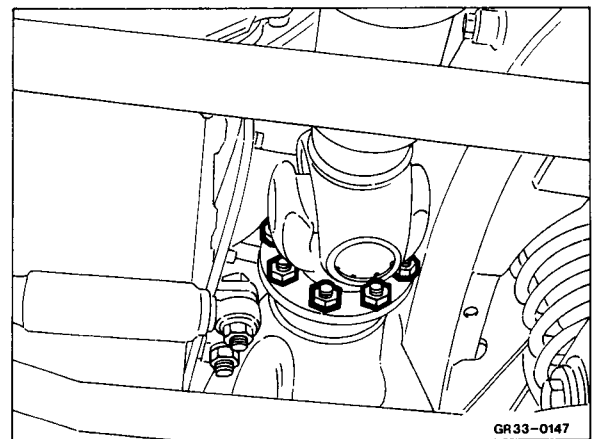

13 Bleed brake system and check for leakage, see 42.50 – 5.1/1.

Side member – Tightening torques

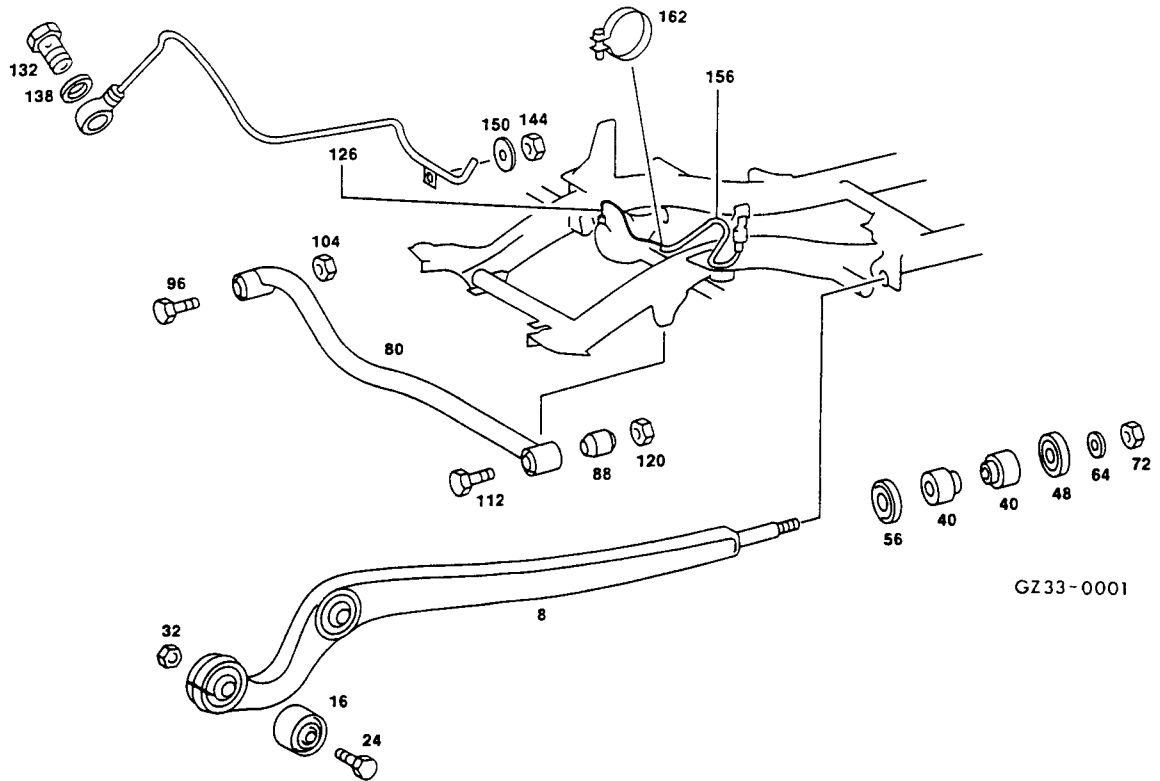
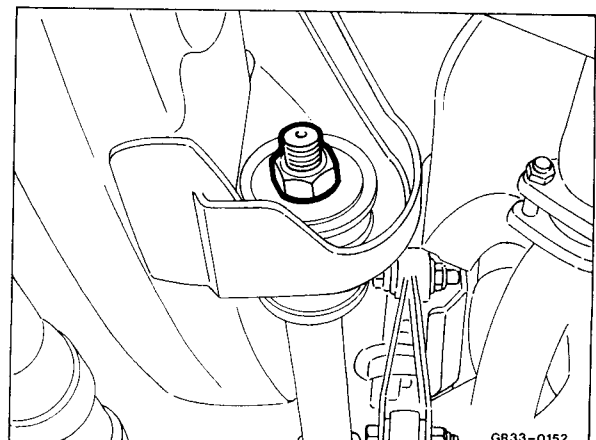

Fig. no.	Designation	Thread	Nm
24/32	Trailing arm to front axle	M 16 x 1,5 – 8.8	210
72	Trailing arm to frame	M 16 x 1,5 – 8.8	130

Removal

- 1 Unscrew trailing arm at frame and at axle.
- 2 Unscrew stabilizer.
- 3 Detach tie rod.
- 4 Remove trailing arm.



- 5 Remove bearing with press and suitable pipe.

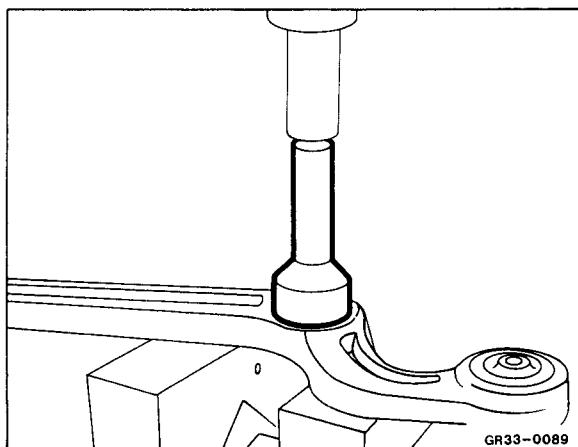

Installation

- 1 Press in bearing.

Note: The bearings should extend an equal distance at both sides.

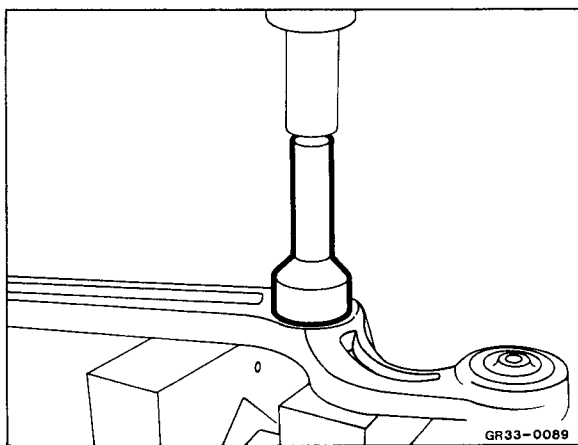

- 2 Install trailing arms, tighten nuts on frame to 130 Nm, tighten bolts on axle to 210 Nm.

- 3 Attach tie rod.

- 4 Bolt on stabilizer.

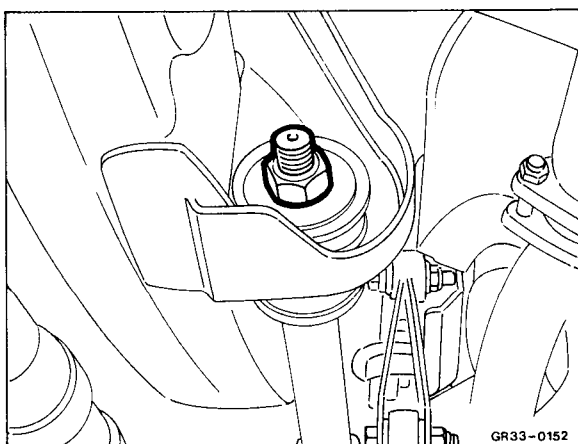

Setting values

Permissible wheel bearing clearance	mm	0,01 to 0,03 ¹⁾
-------------------------------------	----	----------------------------

1) With used bearings aim for wheel bearing clearance of 0,03 mm.

Special tools

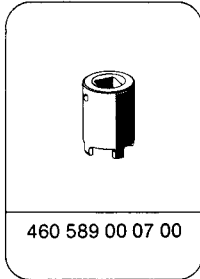

460 589 00 07 00

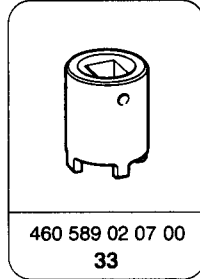

460 589 02 07 00
33

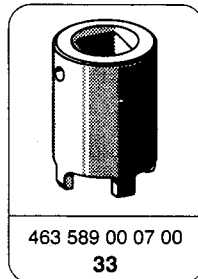

463 589 00 07 00
33

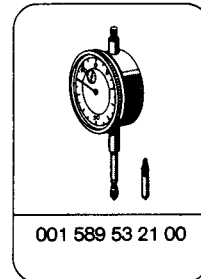

001 589 53 21 00

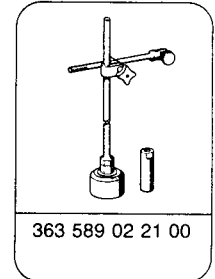

363 589 02 21 00

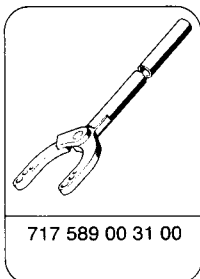

717 589 00 31 00

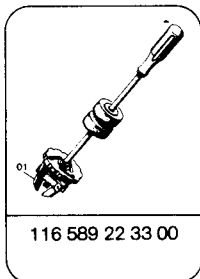

116 589 22 33 00

Expendable materials

Cons. No.	Designation	Part Number
3	Lubricant: multipurpose grease	commercially

Wheel hub – Tightening torques

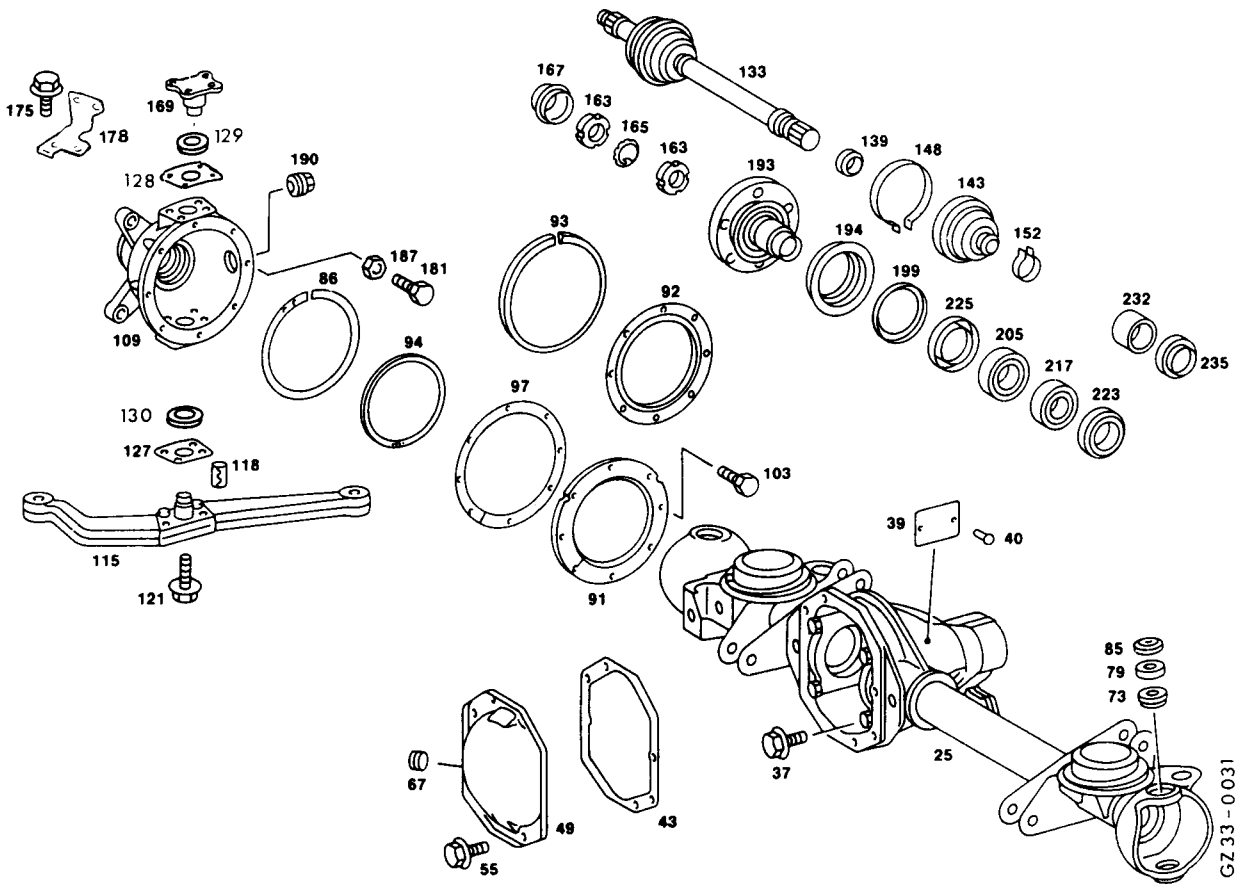

Designation	Thread	Nm
Slotted nut of wheel hub	M 26 x 1,5 –	170 to 190
	M 30 x 1,5 –	
Wheel mounting bolts		
Steel plate disc wheels	M 14 x 1,5 – 10.9	180
Light metal alloy-disc wheels	M 14 x 1,5 – 10.9	130

Test

- 1 Detach road wheel.
- 2 Push back brake pads.

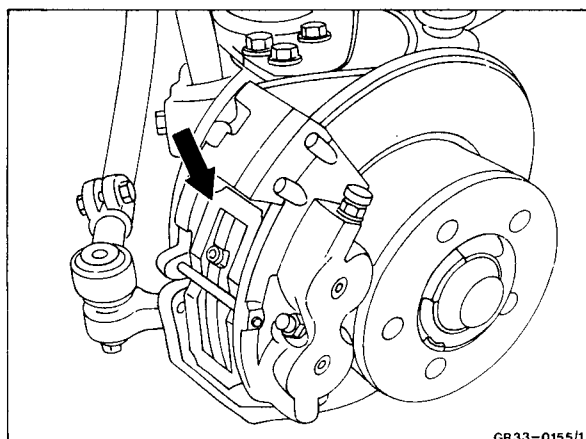

GR33-0155/1

3 Check wheel bearing clearance.

Wheel bearing clearance 0,01 to 0,03 mm.

 001 589 53 21 00
363 589 02 21 00

Note: With used bearings, aim for wheel bearing clearance of 0,03 mm.

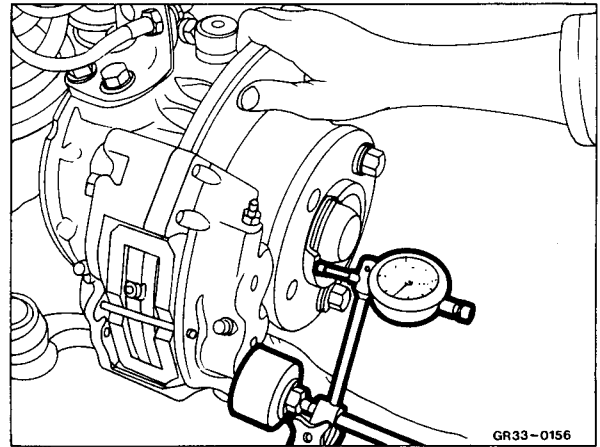

Adjustment

1 Remove grease cap.

 116 589 22 33 00

2 Release slotted nut.

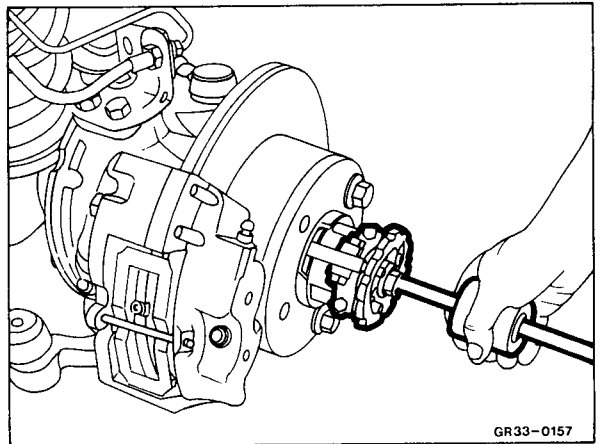

3 Bolt on special tool.

 717 589 00 31 00

4 Unscrew outer slotted nut.

 463 589 00 07 00 (Type 463)
460 589 00 07 00 (Type 461)
460 589 02 07 00 (Type 461)

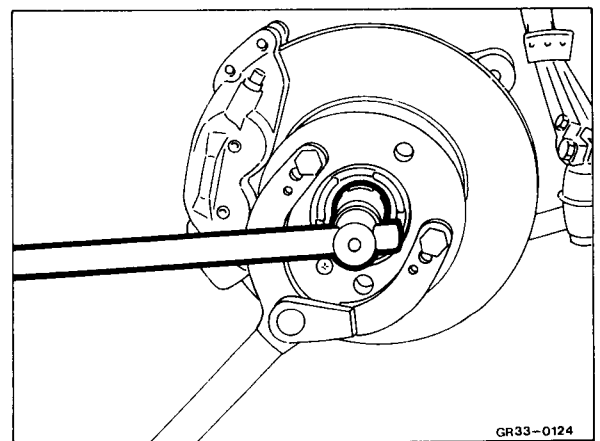

5 Release inner slotted nut. Turn hub several times and, with several hammer blows on the hub, seat and align the tapered rollers, then tighten slotted nut to 200 Nm.

 463 589 00 07 00 (Type 463)
460 589 00 07 00 (Type 461)
460 589 02 07 00 (Type 461)
717 589 00 31 00

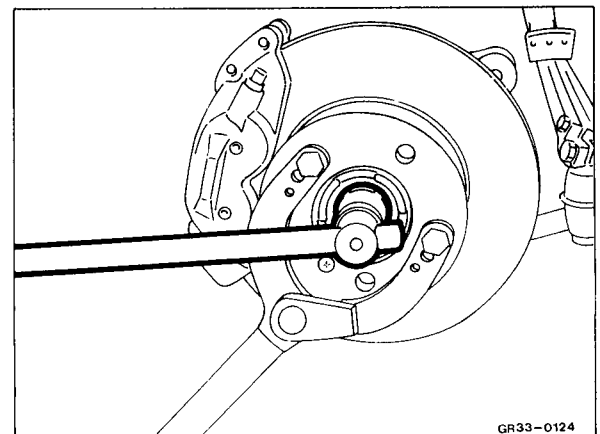

6 Release inner slotted nut and apply again.
(Bearing with no clearance)

7 Slacken inner slotted nut until there is a clearance of approx. 0,1 mm (determine with dial gauge). Insert lock tab.

8 Coat outer slotted nut with lubricant no. 3 and tighten to 170 to 190 Nm.

 463 589 00 07 00 (Type 463)
460 589 00 07 00 (Type 461)
460 589 02 07 00 (Type 461)

Note: The chamfers of the slotted nuts must point to the lock tab side.

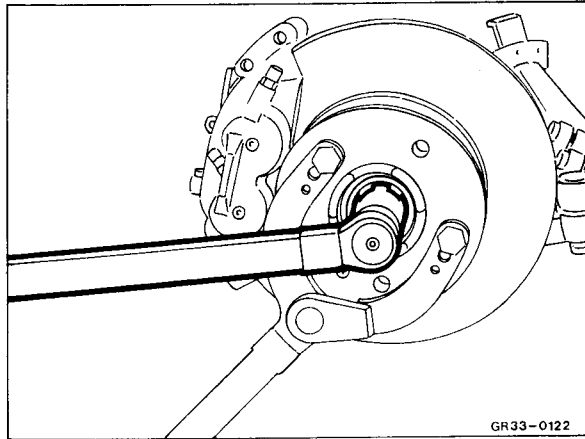

9 Check wheel bearing clearance.

Permissible wheel bearing clearance
0,01 to 0,03 mm.

 001 589 53 21 00
363 589 02 21 00

Note: With used bearings, aim for wheel bearing clearance of 0,03 mm.

10 Secure external slotted nut.

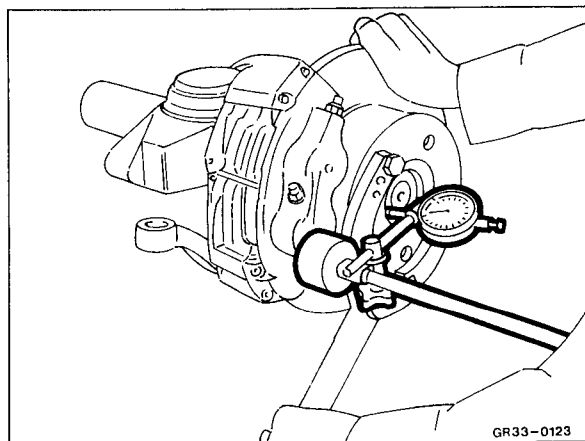

11 Fill grease cap with lubricant no. 3.

12 Install grease cap.

 116 589 22 33 00

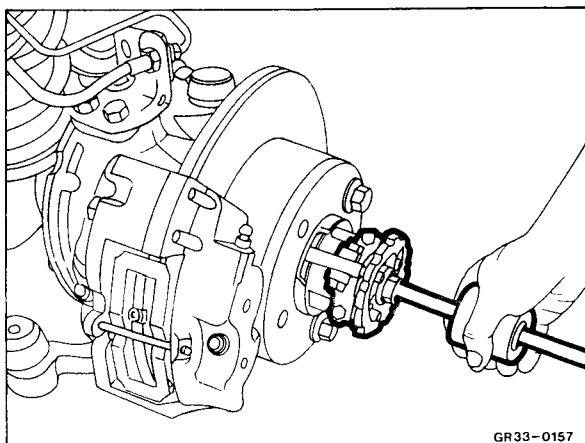

13 Actuate foot brake so that the brake pads move back into basic position.

14 Mount wheels and tighten wheel fastening bolts to the corresponding tightening torque.

Note: Tighten wheel fastening bolts again after 50 km.

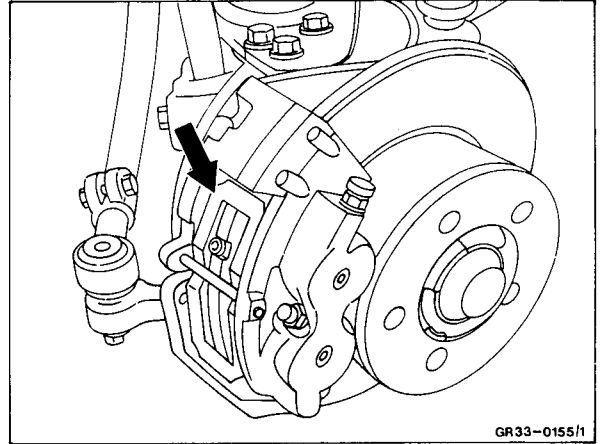

GR33-0155/1

Setting values

Permissible wheel bearing clearance	mm	0,01 to 0,03 ¹⁾
-------------------------------------	----	----------------------------

1) With used bearings, aim for wheel bearing clearance of 0,03 mm.

Special tools 

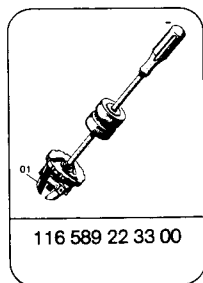
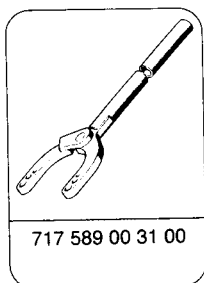
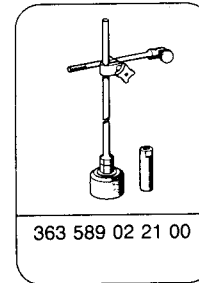
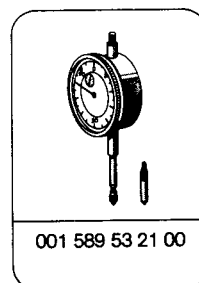
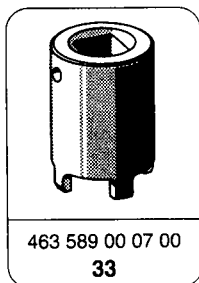
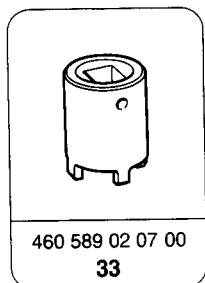
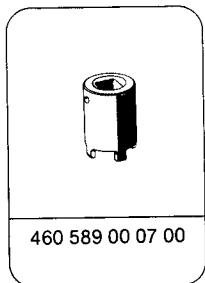

Expendable materials

Cons. No.	Designation	Part Number
3	Lubricant: multipurpose grease	commercially

Front axle – Tightening torques

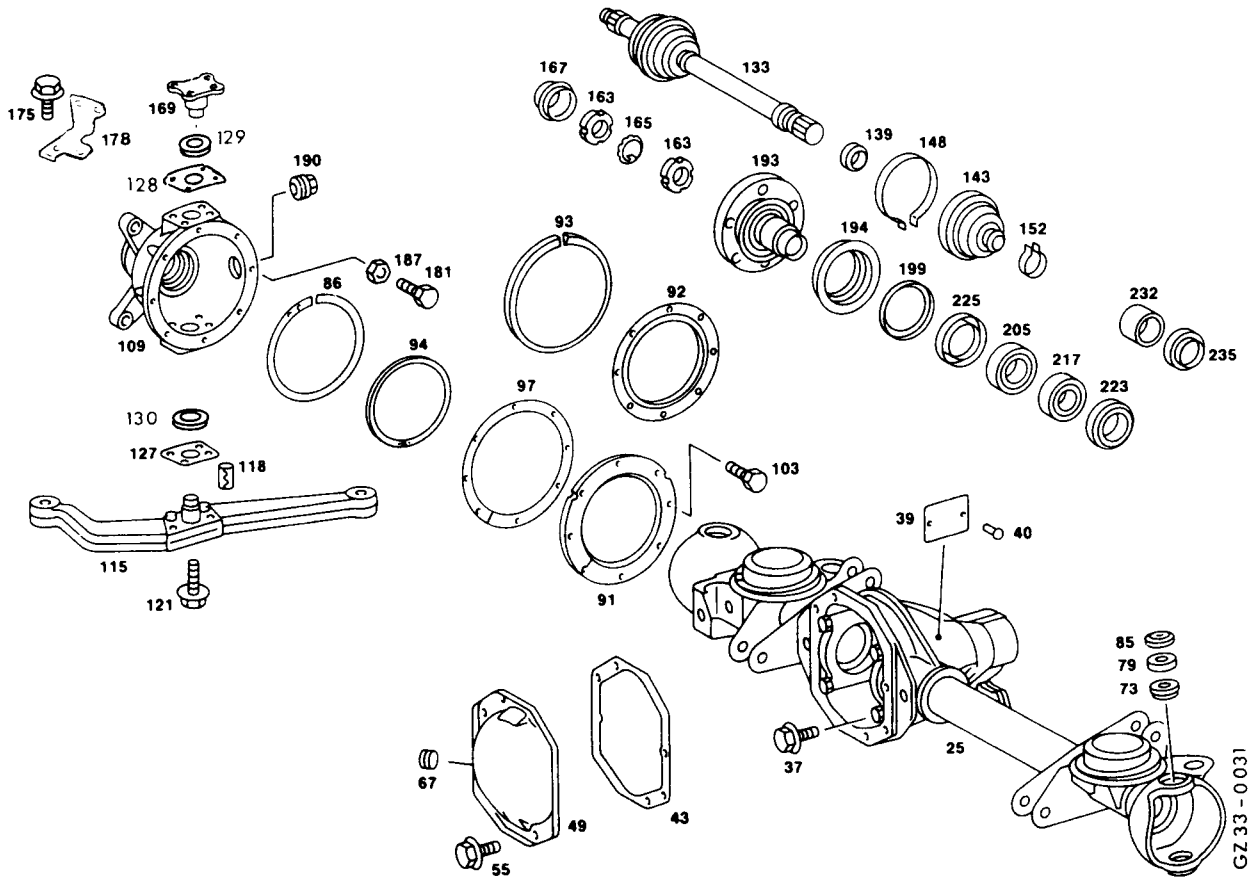
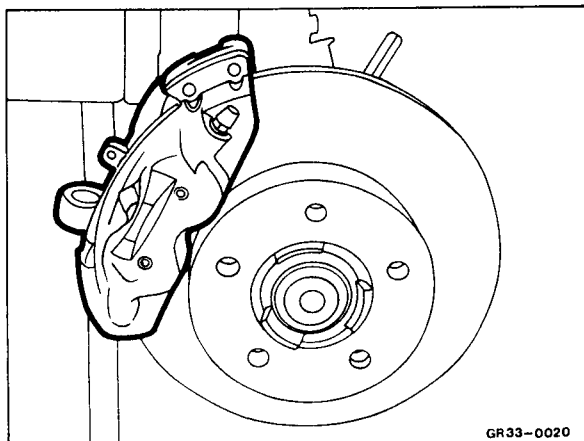

Fig. no.	Designation	Thread	Nm
163	Slotted nut to wheel hub	M 26 x 1,5	170 to 190
		M 30 x 1,5	
-	Fixed caliper to joint housing	M 14 x 1,5 – 10.9	190 to 220
		M 16 x 1,5 – 10.9	250 to 280

Removal

- 1 Remove fixed caliper.
- 2 Remove brake disc.



3 Detach gasket retainer.

Note: Prior to removal, measure the length of the stop screw for the steering angle and readjust this screw to the corresponding value when installing.

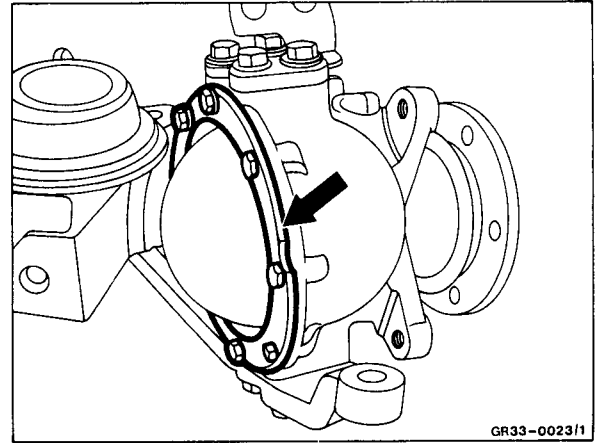

4 Detach kingpin above and steering knuckle arm below.

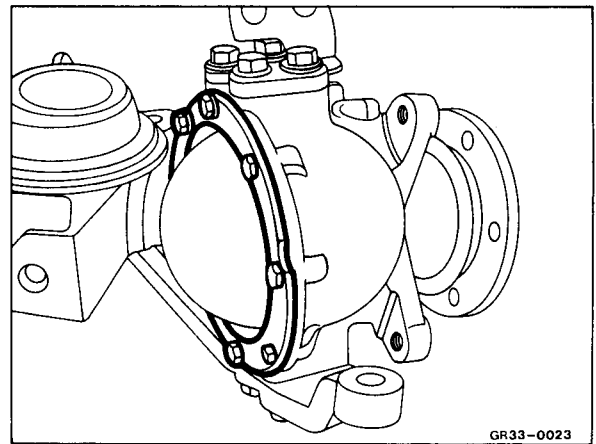

5 Tie shim rings and tapered roller bearing to the kingpins.

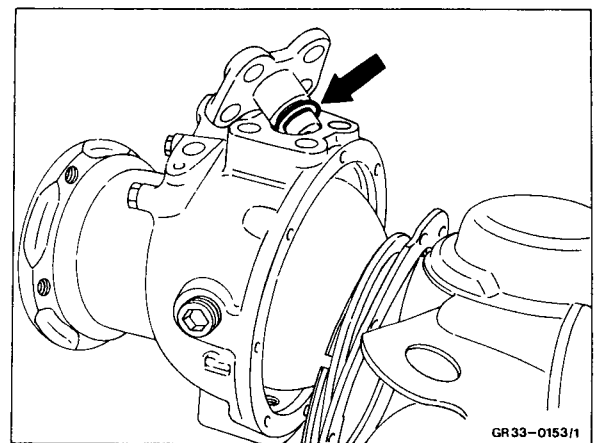

6 Bolt on special tool to wheel hub and clamp.

 717 589 00 31 00

7 Remove grease cap.

 116 589 22 33 00

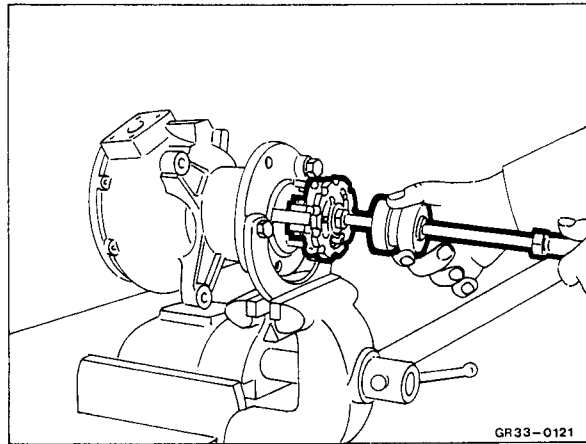

8 Release and unscrew external slotted nut.

9 Remove lock tab.

10 Unscrew inner slotted nut.

 463 589 00 07 00 (Type 463)
460 589 00 07 00 (Type 461)
460 589 02 07 00 (Type 461)

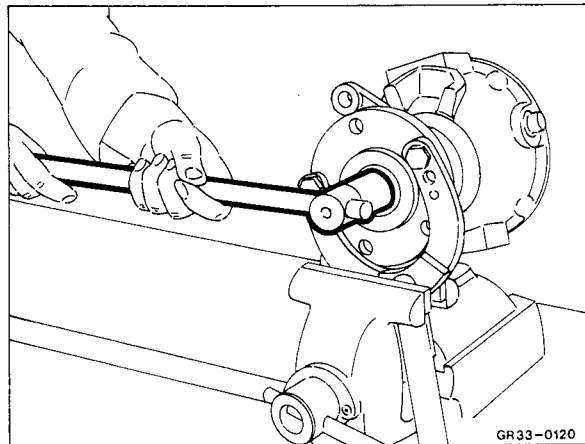

11 Pull out drive shaft.

Note: With anti-lock braking system (ABS) the measuring ring is not to be damaged.

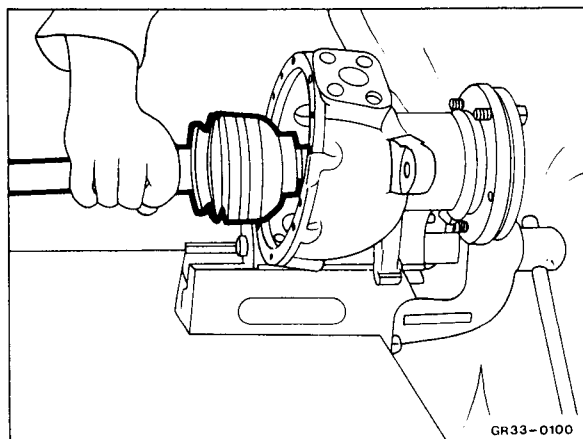

12 Remove joint housing.

13 Clean all parts, check, exchange as required.

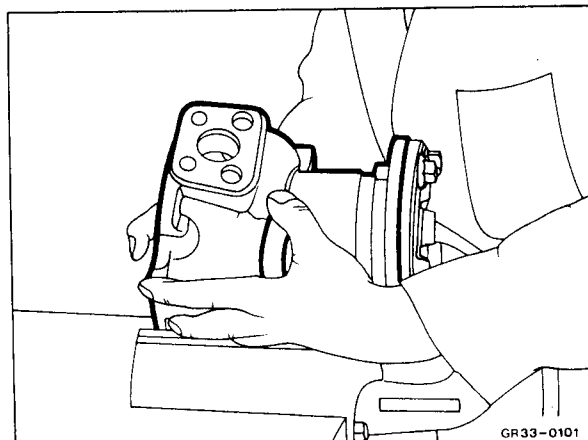

Installation

- 1 Attach joint housing on wheel hub
- 2 Push in drive shaft

Note: With anti-lock braking system (ABS) the measuring ring is not to be damaged.

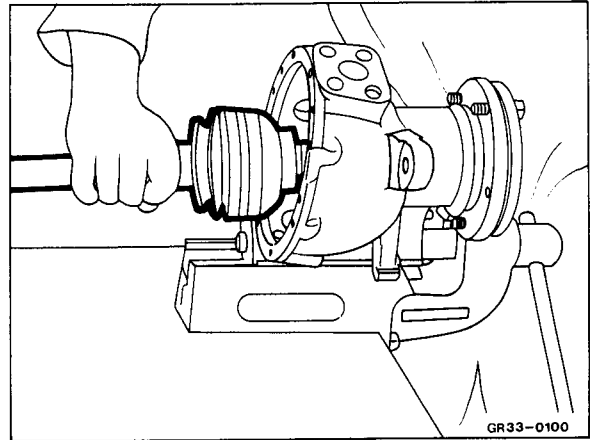
**Adjust wheel bearing clearance**

Note: Only use new slotted nuts and lock tabs.

- 3 Grease inner slotted nut at the contact surface to the wheel hub with lubricant no. 3 and tighten to 200 Nm, simultaneously turning the joint housing. (Settling and aligning of the bearing rollers). Release inner slotted nut until there is a clearance of approx. 0,1 mm (determine with dial gauge). Insert lock tab.

S 463 589 00 07 00 (Type 463)
 460 589 00 07 00 (Type 461)
 460 589 02 07 00 (Type 461)
 717 589 00 31 00

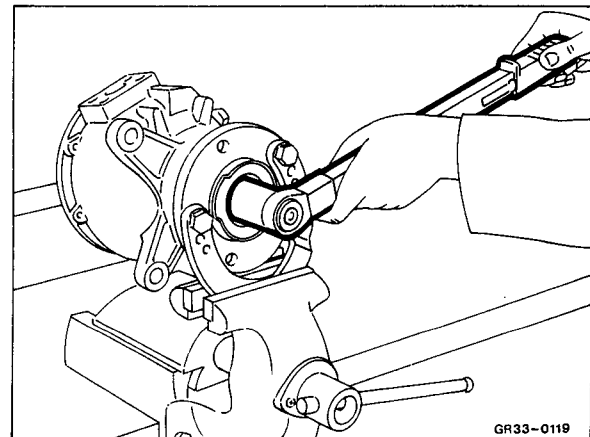

- 4 Coat outer slotted nut with lubricant no. 3 and tighten to 170 to 190 Nm.

S 463 589 00 07 00 (Type 463)
 460 589 00 07 00 (Type 461)
 460 589 02 07 00 (Type 461)
 717 589 00 31 00

Note: The chamfers of the slotted nuts must point to the lock tab side.

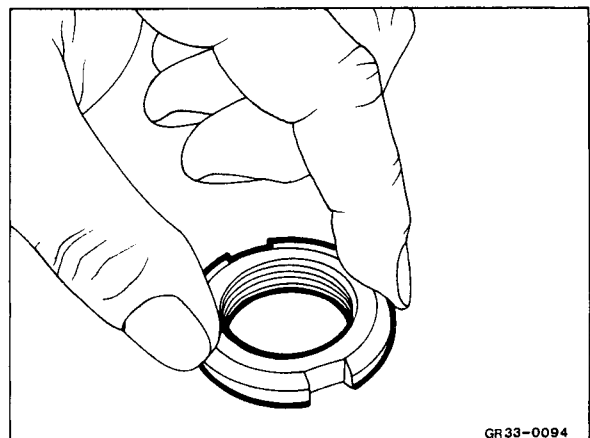

5 Check wheel bearing clearance.

Permissible wheel bearing clearance 0,01 to 0,03 mm.

 001 589 53 21 00
363 589 02 21 00

Note: With used bearings, aim for wheel bearing clearance of 0,03 mm.

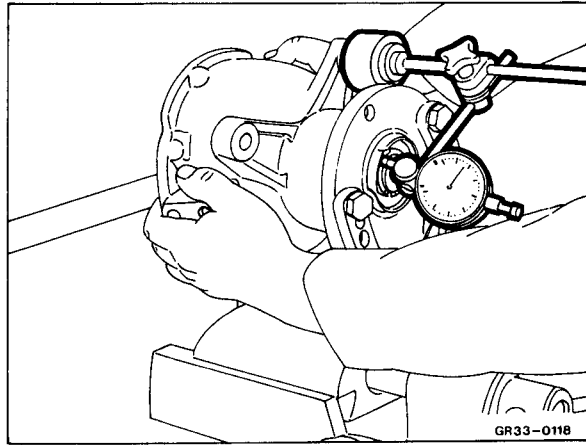

6 Secure external slotted nut.

7 Install grease cap.

 116 589 22 33 00

Note: Pack grease cap with lubricant no. 3.

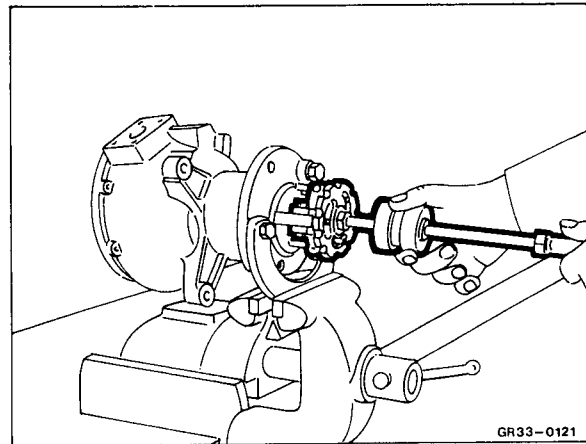

8 Grease tapered roller bearing with lubricant no. 3.

9 Install tapered roller bearing with nilos ring.

10 Install joint housing with drive shaft.

11 Place the corresponding shims under the kingpin and track rod arm and install.

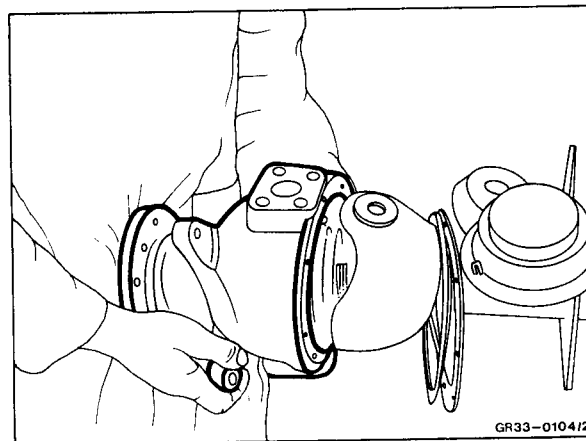

12 Tighten kingpin to 170 to 190 Nm.

13 Tighten track rod arm to 250 to 280 Nm.

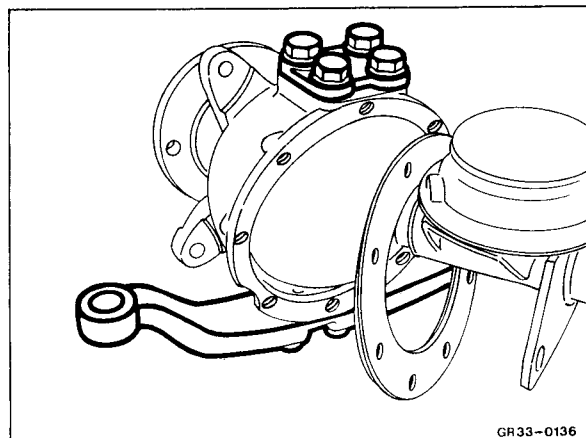

14 Attach gasket retainer on joint housing, tighten bolt to 20 to 25 Nm.

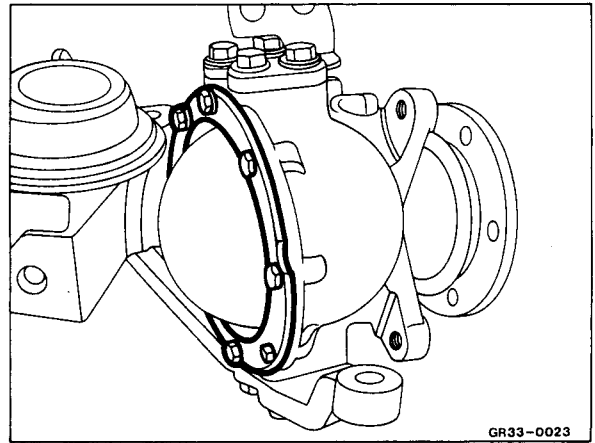

15 Fill joint housing with lubricant no. 3.
Capacity per housing 800 g.

16 Tighten screw plug to 100 Nm.

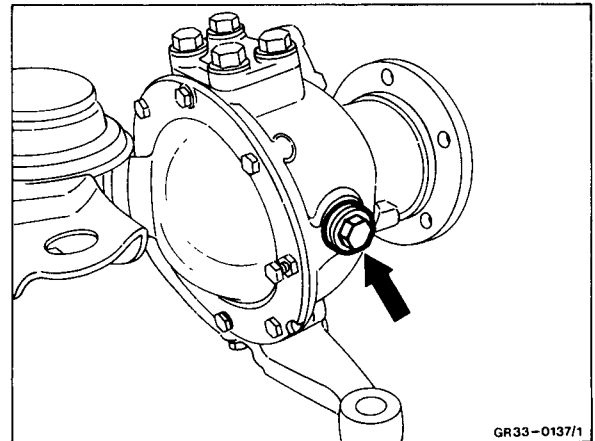

17 Install brake disc.

18 Attach fixed caliper and tighten
M 14 x 1,5 bolt to 190 to 220 Nm and
M 16 x 1,5 bolt to 250 to 280 Nm.

19 Check steering angle and adjust if necessary,
refer to 40.50 – 4.1/1.

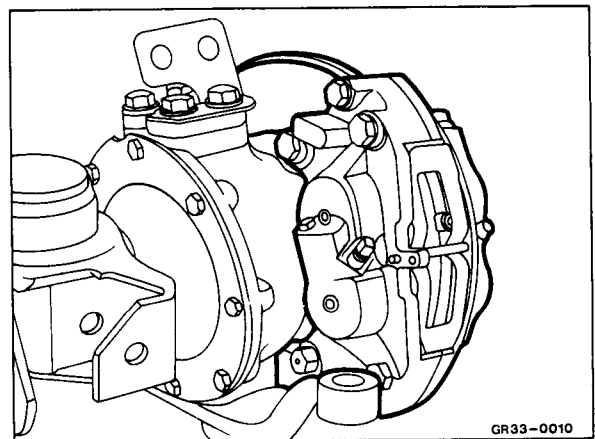

Special tools 

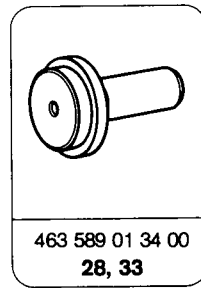
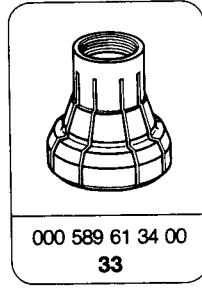
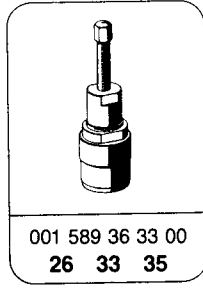
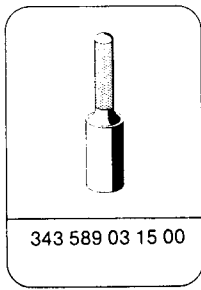

Expendable materials

Cons. No.	Designation	Part Number
2	Sealing compound: Omnifit FD 10	002 989 00 20 10
3	Lubricant: multipurpose grease	commercially

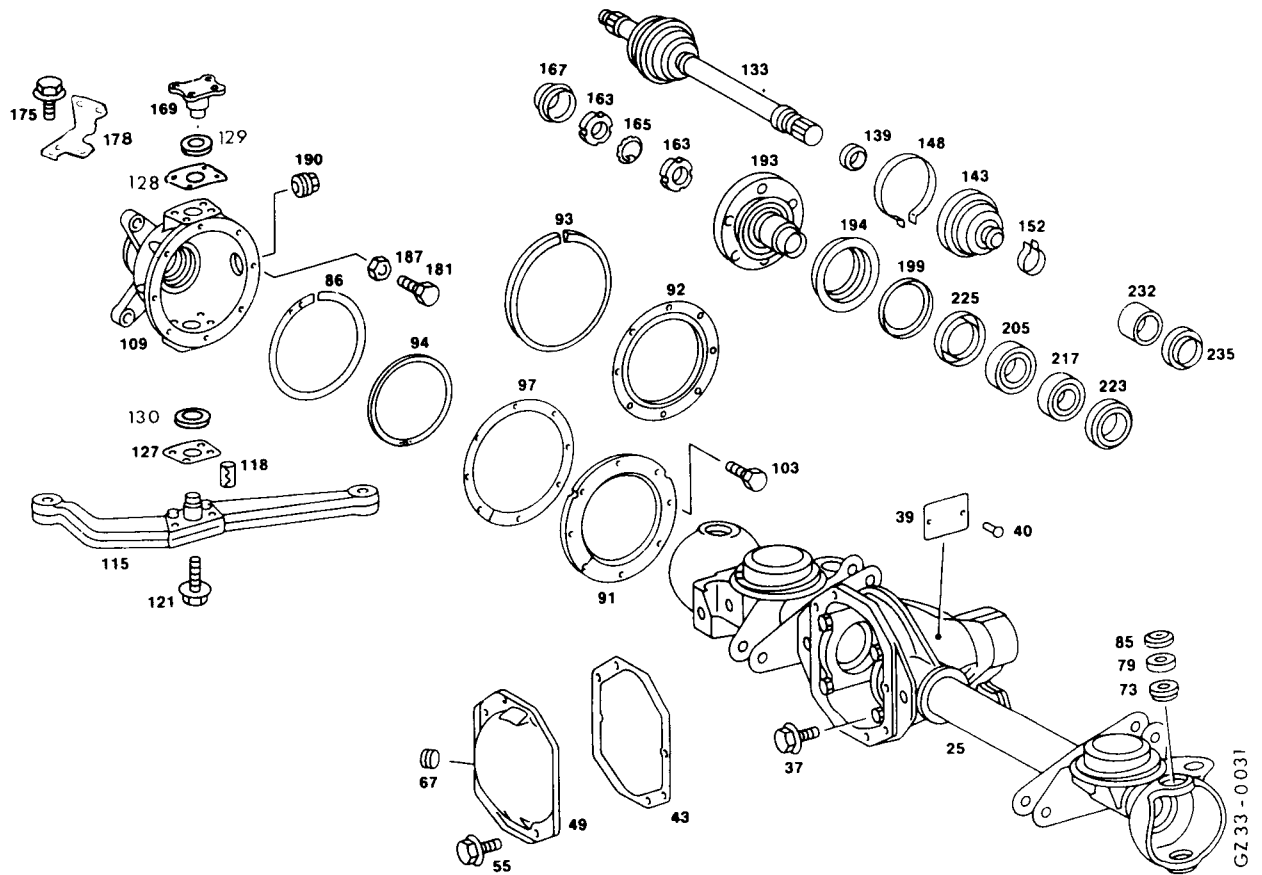

Disassembly

1 Remove tapered roller bearing.

 000 589 61 34 00
463 589 01 34 00

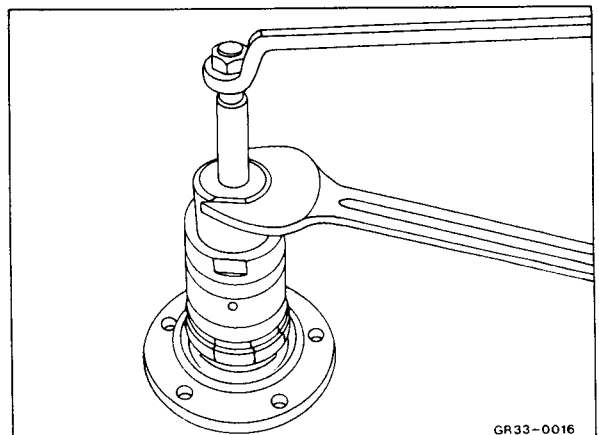

- 2 Remove cellular polyurethane ring.
- 3 Check cellpolyurethane ring and replace if necessary.

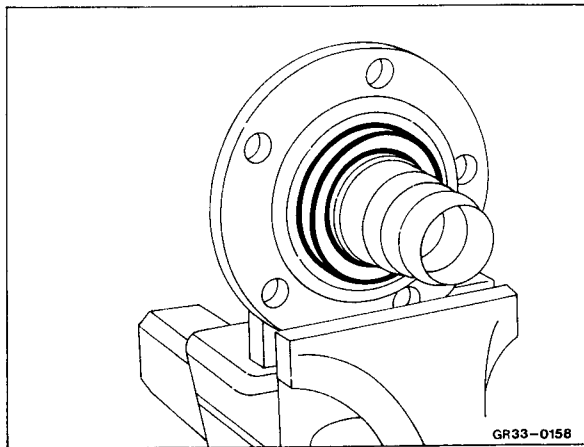

Assembly

- 1 Grease new cell-polyurethane ring with lubricant no. 1 grease.
- 2 Insert cellpolyurethane ring.

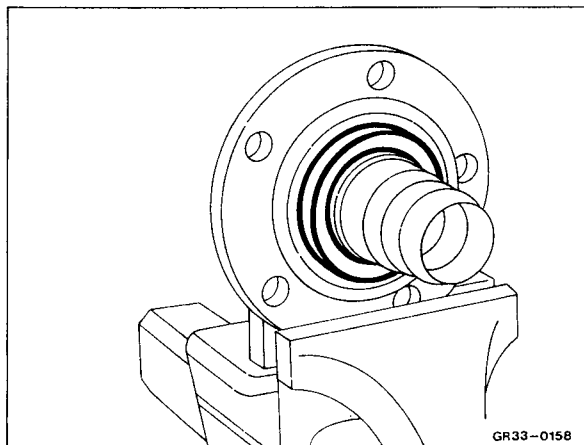

- 3 Install tapered roller bearing.

 343 589 03 15 00

- 4 Pack cavity in steering knuckle housing, between the tapered roller bearings, with 80 gr. of lubricant no. 3, at the same time make sure that the tapered roller bearing is well greased.

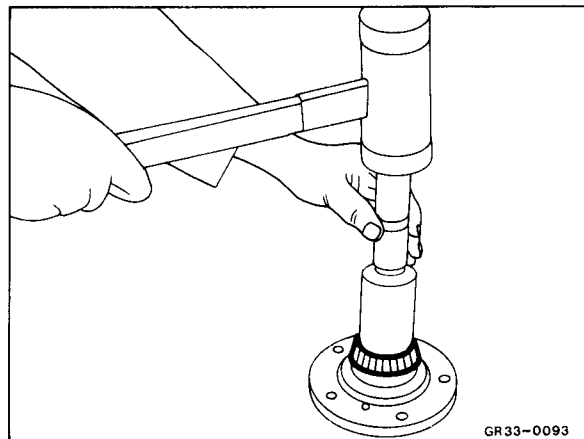

Setting values

Steering knuckle bearing preload	mm	0,30 ± 0,05
Permissible wheel bearing clearance	mm	0,01 to 0,03 ¹⁾
Toe-in	mm	0 to 0,75

1) With used bearings, aim for wheel bearing clearance of 0,03 mm.

Special tools

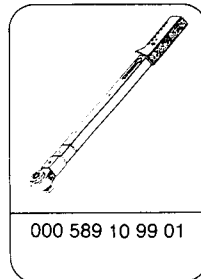
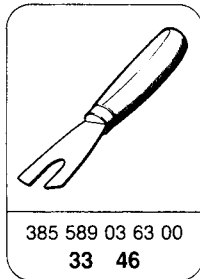
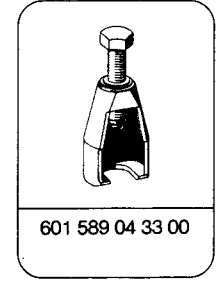
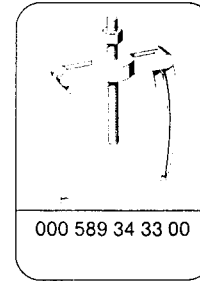
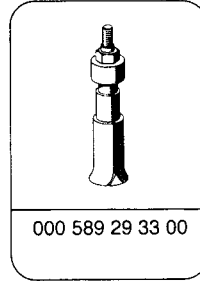
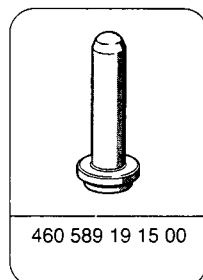
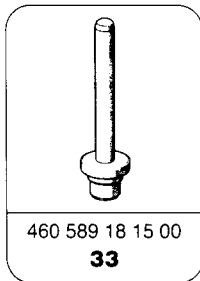

Expendable materials

Cons. No.	Designation	Part Number
3	Lubricant: multipurpose grease	commercially

Joint housing – Tightening torques

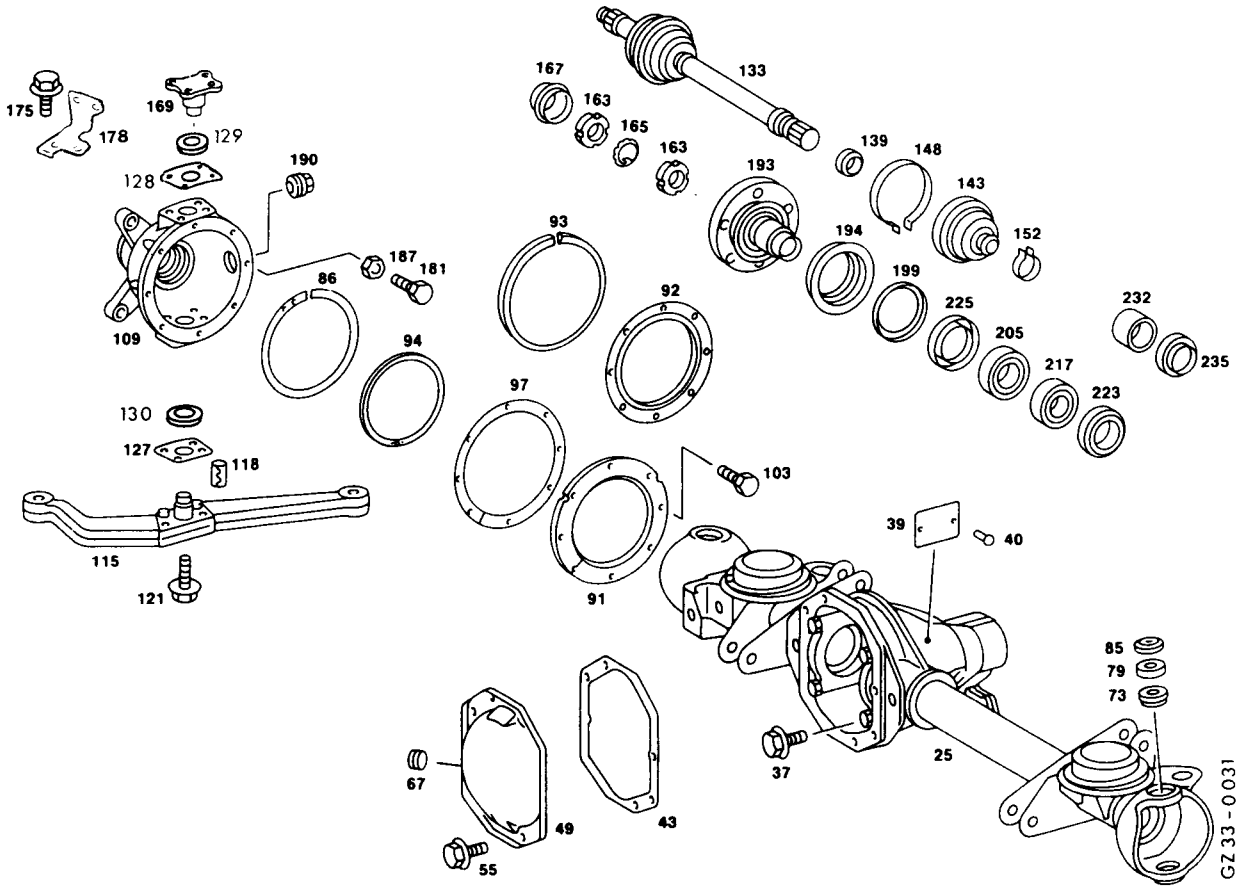
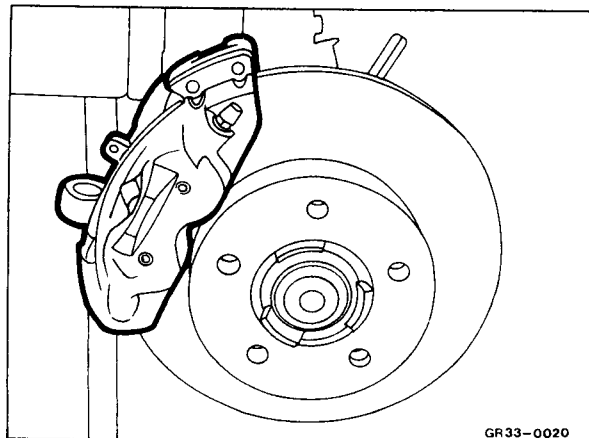

Fig. no.	Designation	Thread	Nm
103	Gasket retainer to joint housing	M 8 x 18 – 8.8	20 to 25
121	Steering arm to joint housing	M 14 x 1,5 – 12.9	250 to 280
175	Kingpin to joint housing	M 14 x 1,5 – 12.9	170 to 190
–	Tie rod to steering arm	M 16 x 1,5	120 to 140

Removal

- 1 Remove fixed caliper.
- 2 Remove brake disc.



GR33-0020

3 Unscrew steering shock absorber.

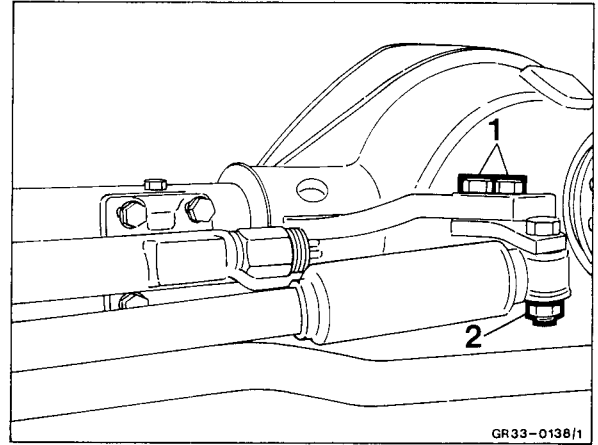

Type 463

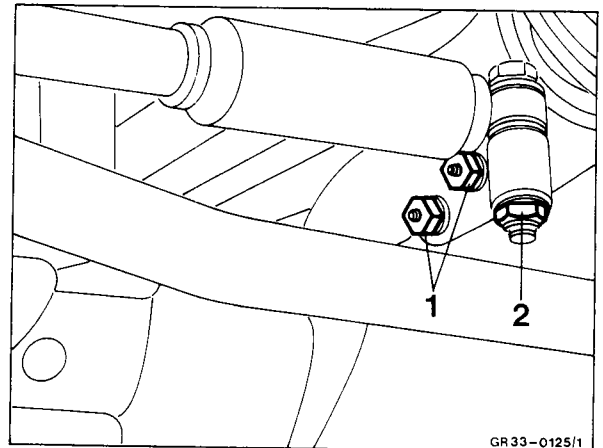

Type 461

4 Unscrew castle nut, press off tie rod.

 601 589 04 33 00

Note: Check tie rod end for rust by lifting the gaiter. Check ball heads for play. Replace tie rod end if necessary.

 385 589 03 63 00

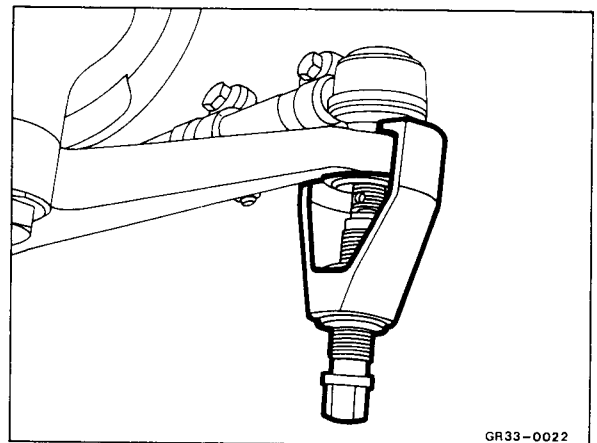

5 Detach gasket retainer.

Note: Prior to removal, measure the length of the stop screw for the steering angle and readjust this screw to the corresponding value when installing.

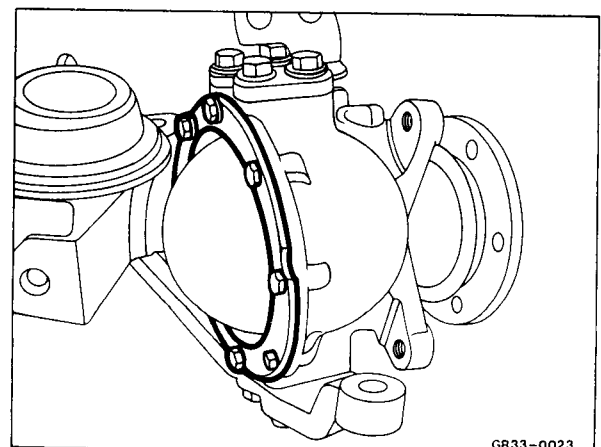

6 Detach kingpin above and steering knuckle arm below.

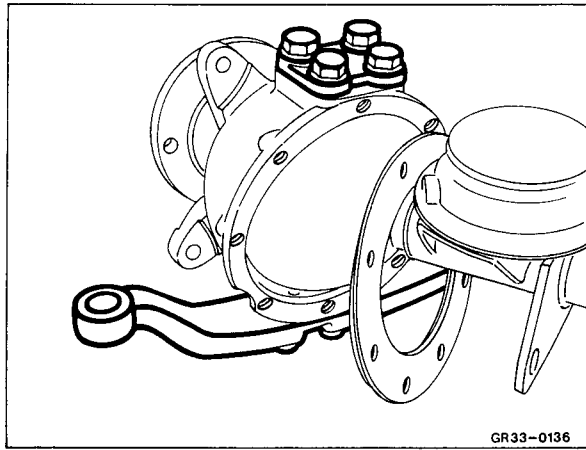

7 Tie shim rings and tapered roller bearing to the kingpins.

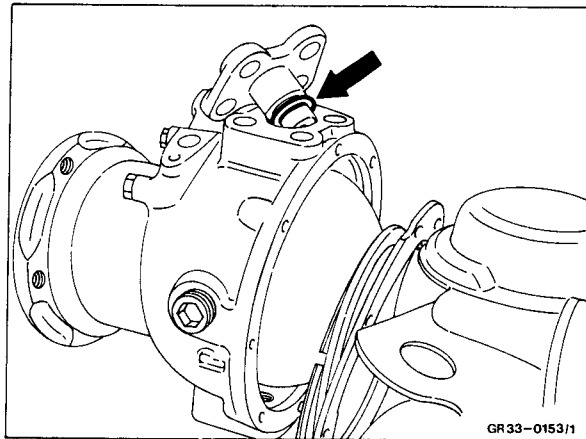

Type 463

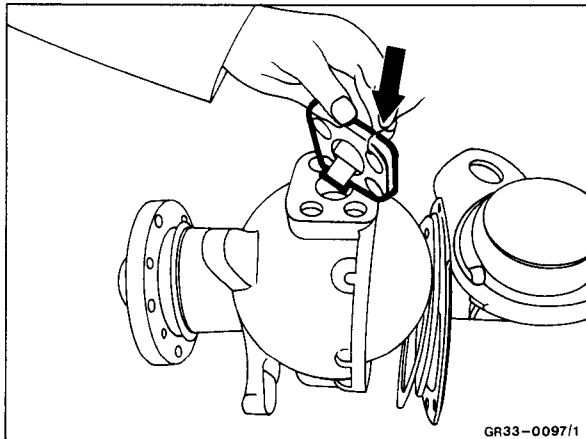

Type 461

8 Remove joint housing.

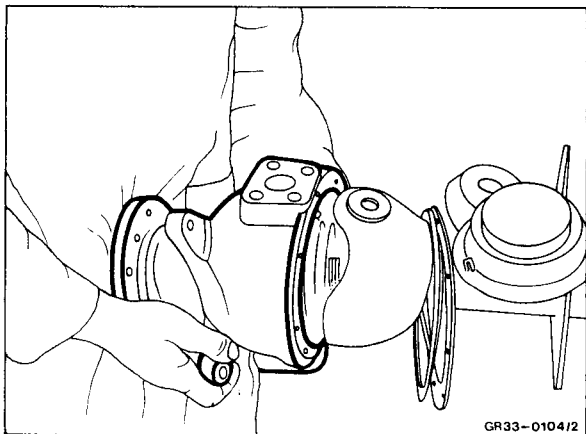

- 9 Replace paper gasket and sealing ring (1).

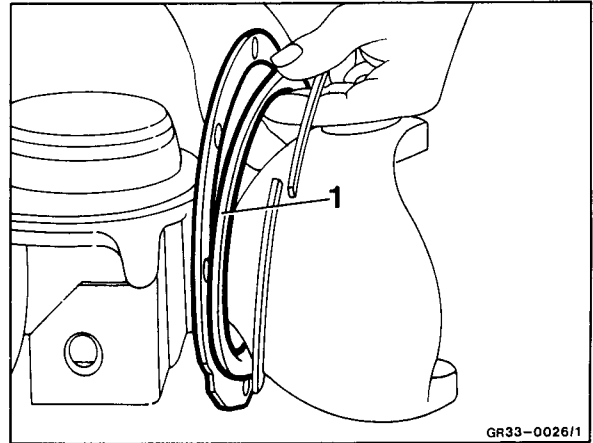

- 10 Centre punch cap with suitable drift.

- 11 Remove outer bearing race at top and bottom.

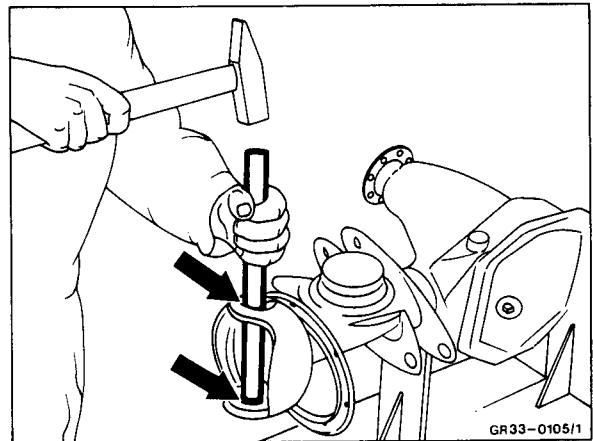

- 12 Remove sealing ring and bearing bushing.

 000 589 29 33 00
000 589 34 33 00

- 13 Clean all parts, check, exchange as required.

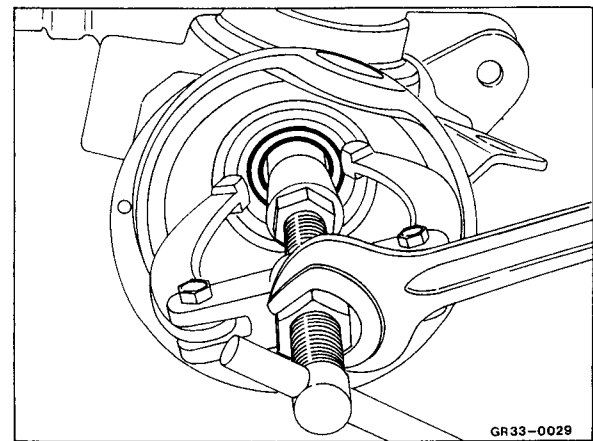

Installation

- 1 Install bearing bushing.

- 2 Coat new shaft seal with lubricant no. 3 and drive in flush.

 460 589 18 15 00

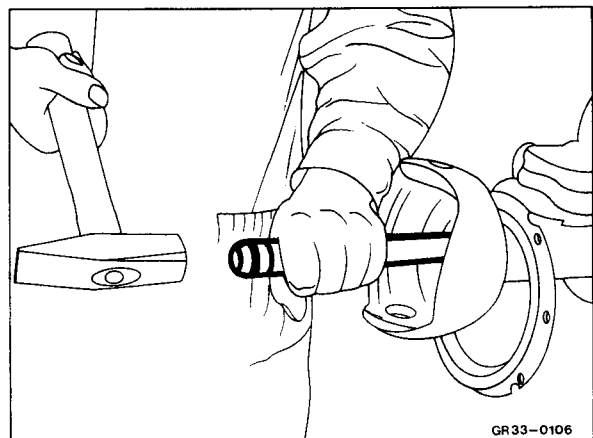

3 Install cap.

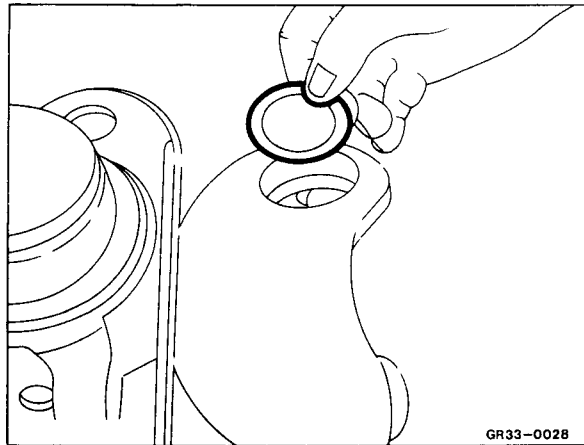

4 Install outer bearing race.

B 460 589 19 15 00

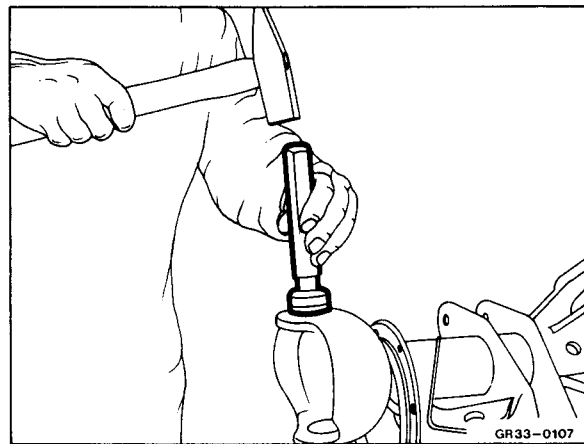

5 Grease tapered roller bearing with lubricant no. 3.

6 Install tapered roller bearing with nilos ring.

7 Install joint housing with drive shaft.

8 Adjust steering knuckle bearing, refer to 5.5/1.

9 Place corresponding shims under the kingpin and track rod arm and install.

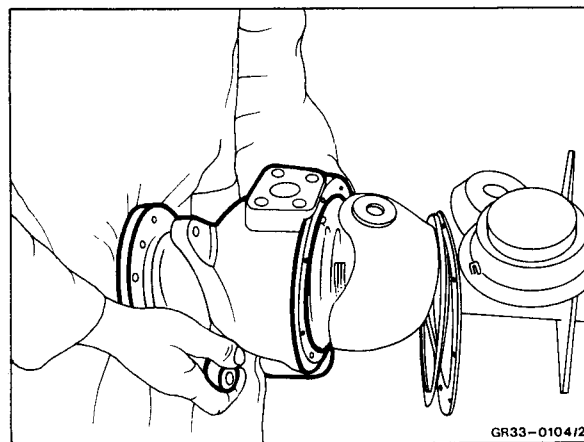

10 Tighten kingpin to 170 to 190 Nm.

11 Tighten track rod arm to 250 to 280 Nm.

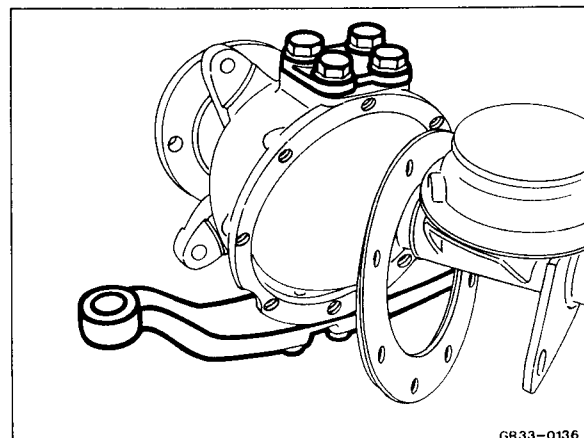

12 Attach gasket retainer on joint housing, tighten bolt to 20 to 25 Nm.

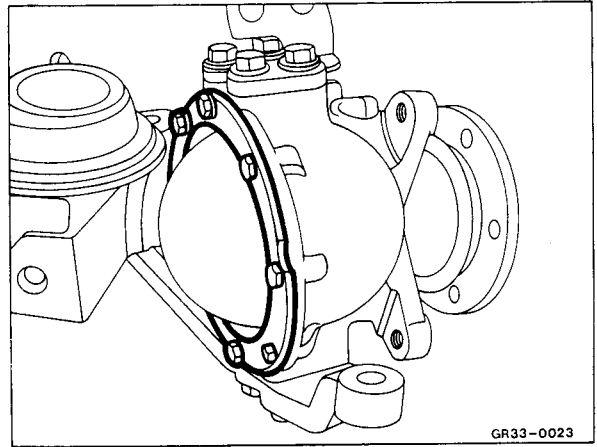

13 Fill joint housing with lubricant no. 3.
Capacity per housing 800 g.

14 Tighten screw plug to 100 Nm.

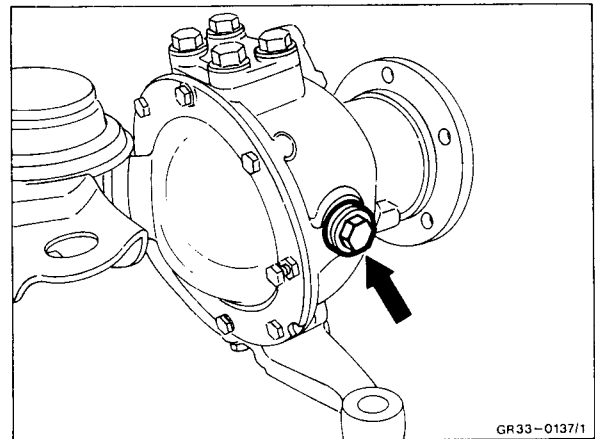

15 Install brake disc.

16 Attach fixed caliper and tighten
M 14 x 1,5 bolt to 190 to 220 Nm and
M 16 x 1,5 bolt to 250 to 280 Nm.

Note: Micro-encapsulated bolts must be renewed.

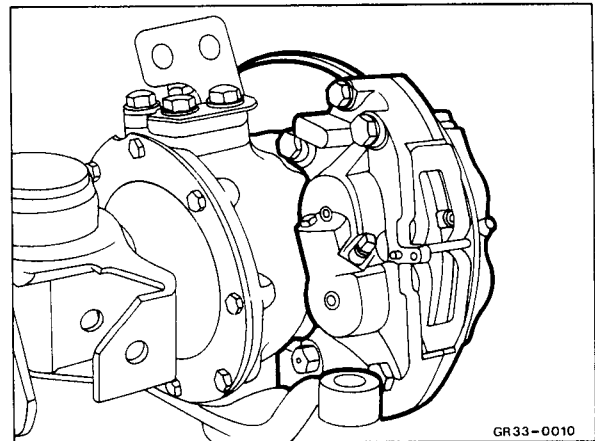

Note: Before installation degrease shank of ball pin as well as bore of steering arm.

17 Install tie rod and tighten the castle nut to 120 to 140 Nm.

Secure castle nut with cotter pin.

18 Adjust toe-in 0 ± 2 mm.

Note: Adjustment of toe-in only under load of wheels with vehicle weight.

(Toe-in = difference between the distances of the rim rings in height of the wheel center with the wheels pointing forwards.)

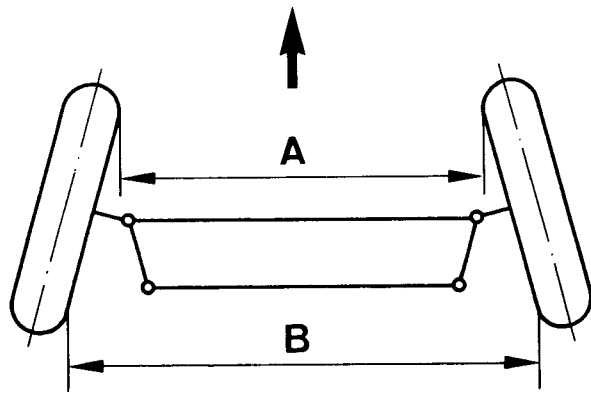

GZ33-0014/1

19 Install steering damper and with 20° left-hand steering angle tighten bolts (1) to 25 Nm and (2) to 50 Nm.

20 Check steering wheel turning angle and adjust if necessary, refer to 40.50 – 4.1/1.

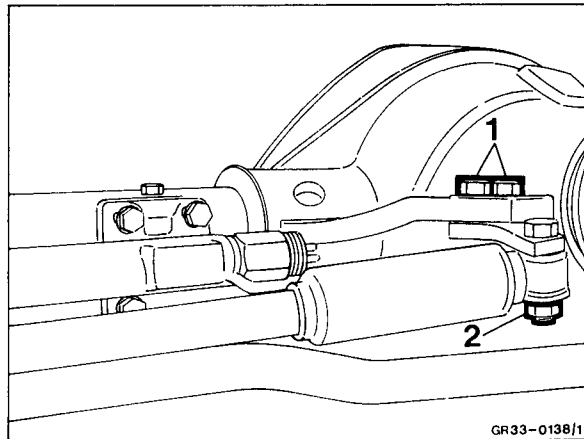

GR33-0138/1

Type 463

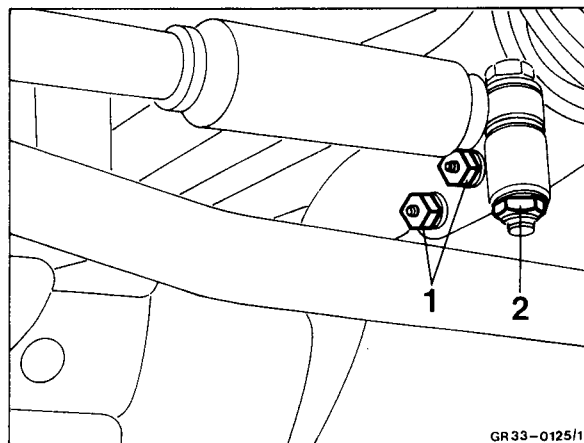

GR33-0125/1

Type 461

Special tools 

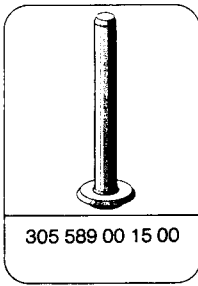

305 589 00 15 00

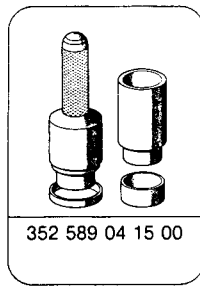

352 589 04 15 00

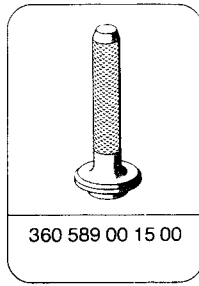

360 589 00 15 00

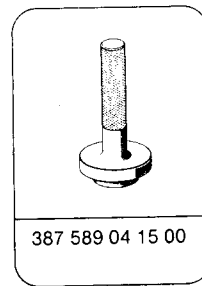

387 589 04 15 00

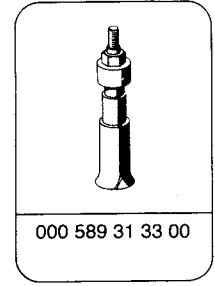

000 589 31 33 00

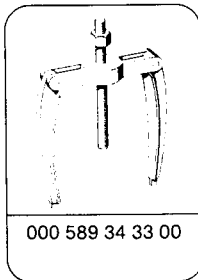

000 589 34 33 00

Expendable materials

Cons. No.	Designation	Part Number
2	Sealing compound: Omnifit FD 10	002 989 00 20 10
3	Lubricant: multipurpose grease	commercially

Joint housing

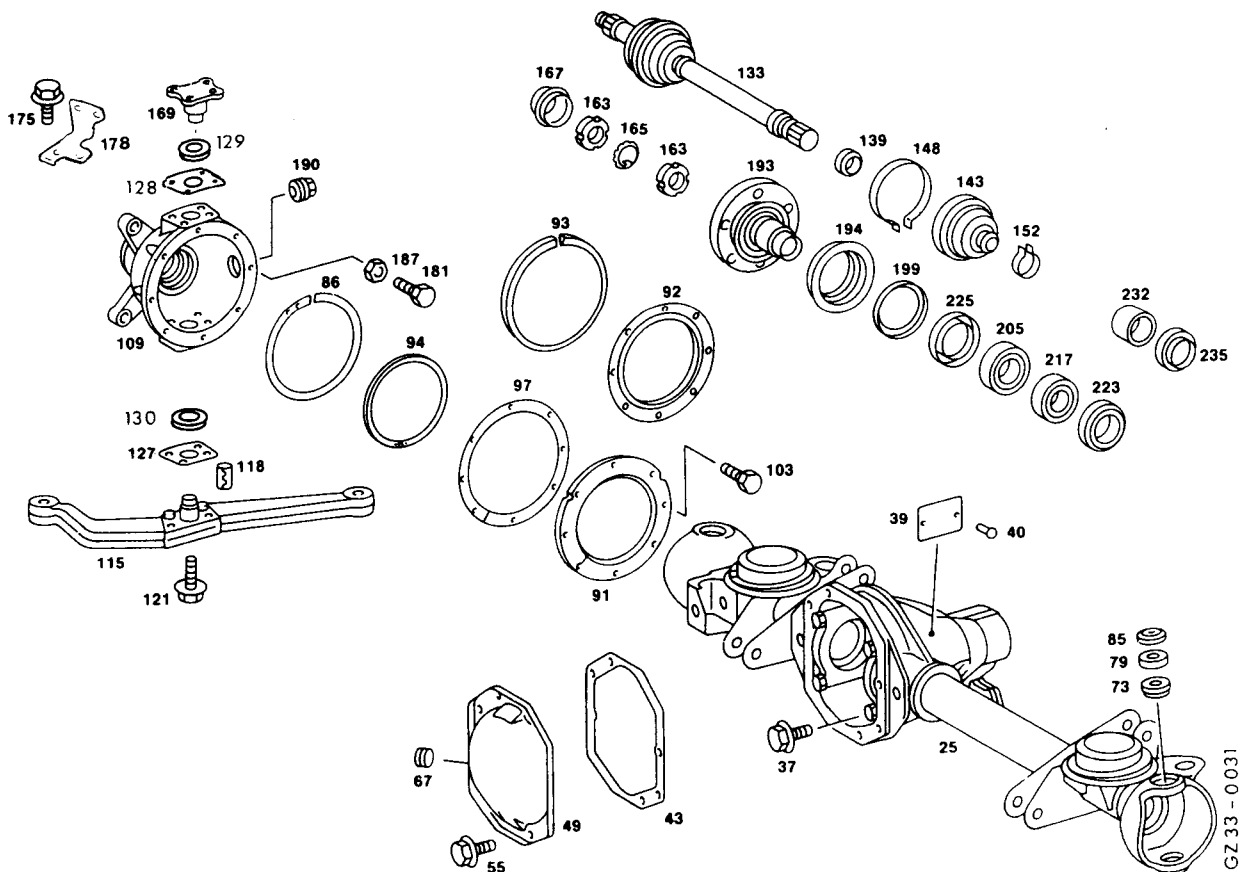

GZ 33 - 0.031

Disassembly

- 1 Remove sealing rings.

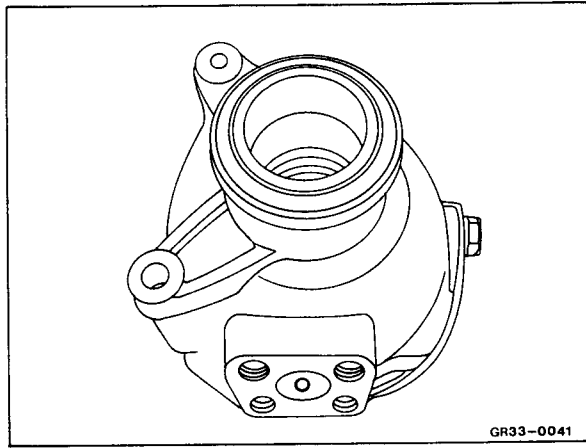

- 2 Remove outer bearing race.

 000 589 31 33 00
000 589 34 33 00

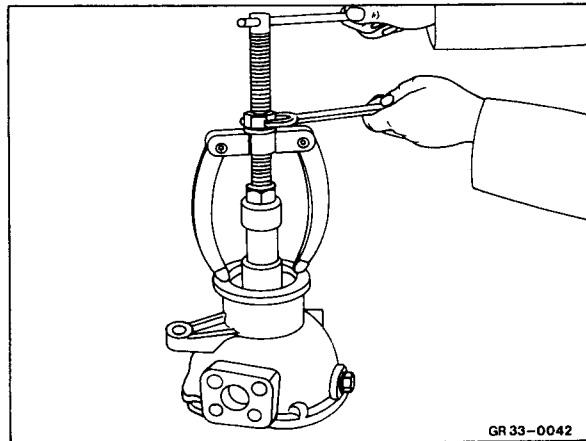

- 3 Remove wheel bearing and sealing ring.

 360 589 00 15 00

- 4 Clean bearing, check, exchange as required.

- 5 Exchange sealing ring.

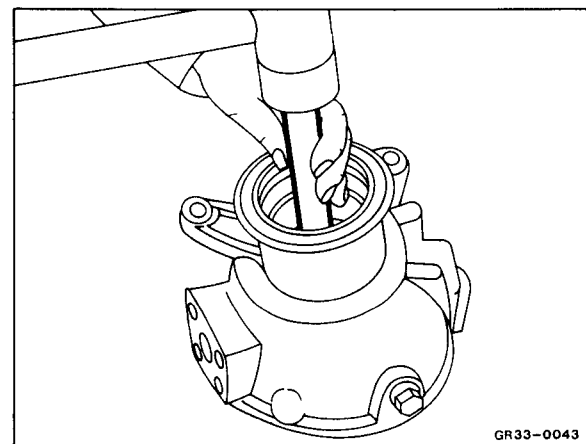

Assembly

- 1 Install outer bearing race.

 352 589 04 15 00

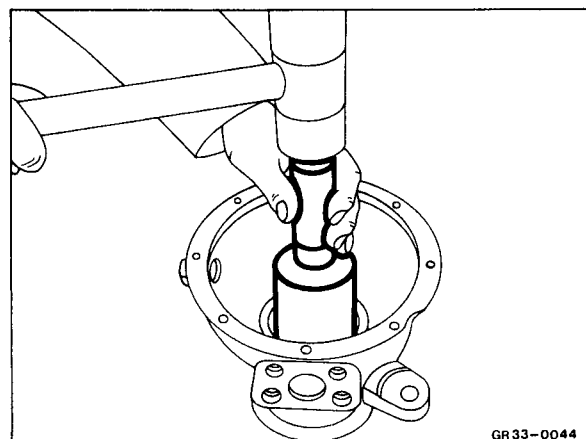

2 Grease bearing well with lubricant no. 3 and insert in housing.

3 Coat sealing ring around circumference with sealing compound no. 2 and install.

Note: Install sealing rings with external rubber coating **without** sealing compound.

 305 589 00 15 00

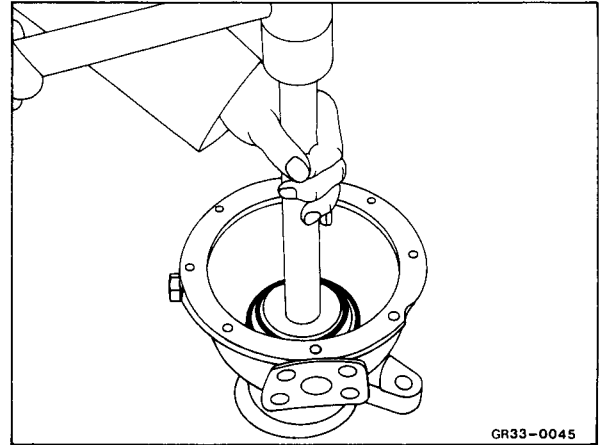

GR33-0045

4 Install outer bearing race.

 305 589 00 15 00

5 Coat sealing ring with sealing compound no. 2 and install.

 387 589 04 15 00

Note: Drive in sealing rings flush (max. 0,3 mm lower).

– Install sealing rings with external rubber coating **without** sealing compound.

6 Fill joint housing with lubricant no. 3.

Capacity per housing 800 g.

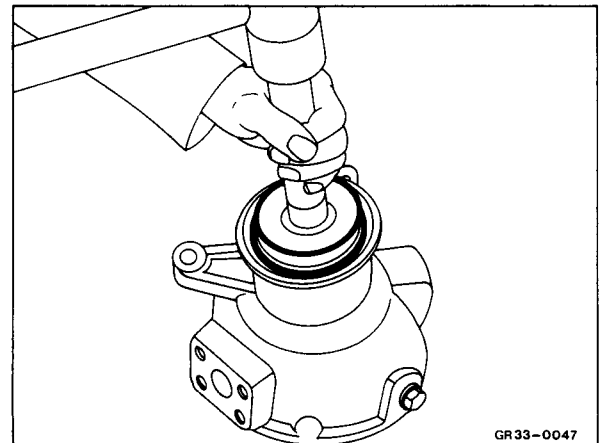

GR33-0047

7 Well grease bearing with lubricant no. 3 and drive onto wheel hub.

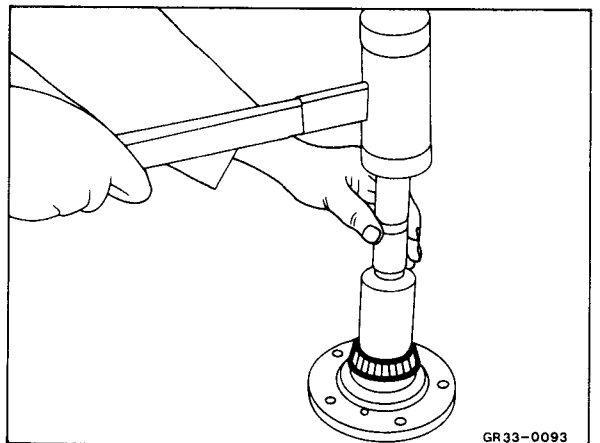

GR33-0093

Note: In the event of repairs, check guide bushings for damage and renew if necessary, when doing so, radially align the slots of the guide bushings.

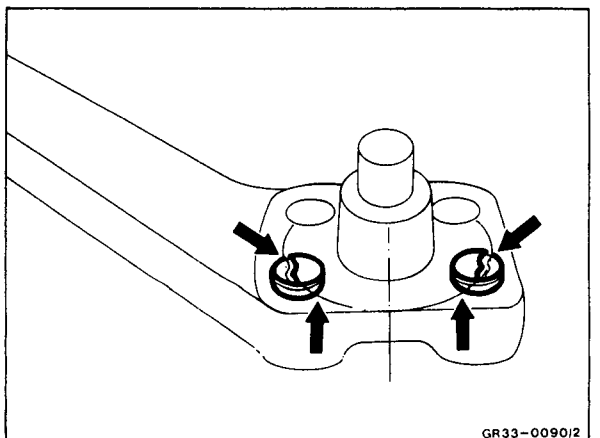

GR33-0090/2

Special tools 

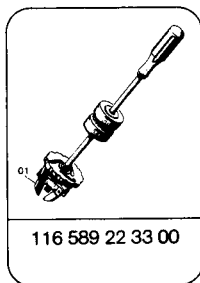
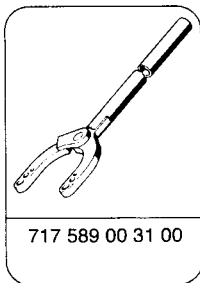
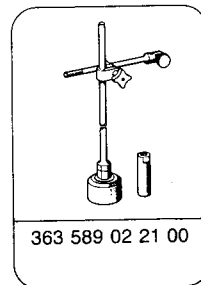
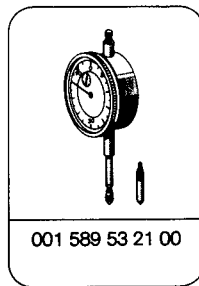
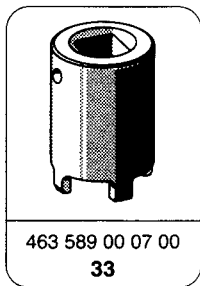
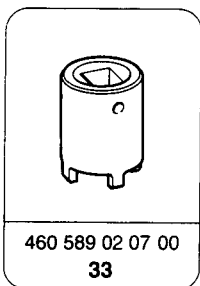
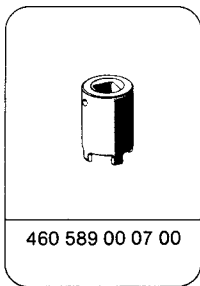

Expendable materials

Cons. No.	Designation	Part Number
3	Lubricant: multipurpose grease	commercially

Input shaft

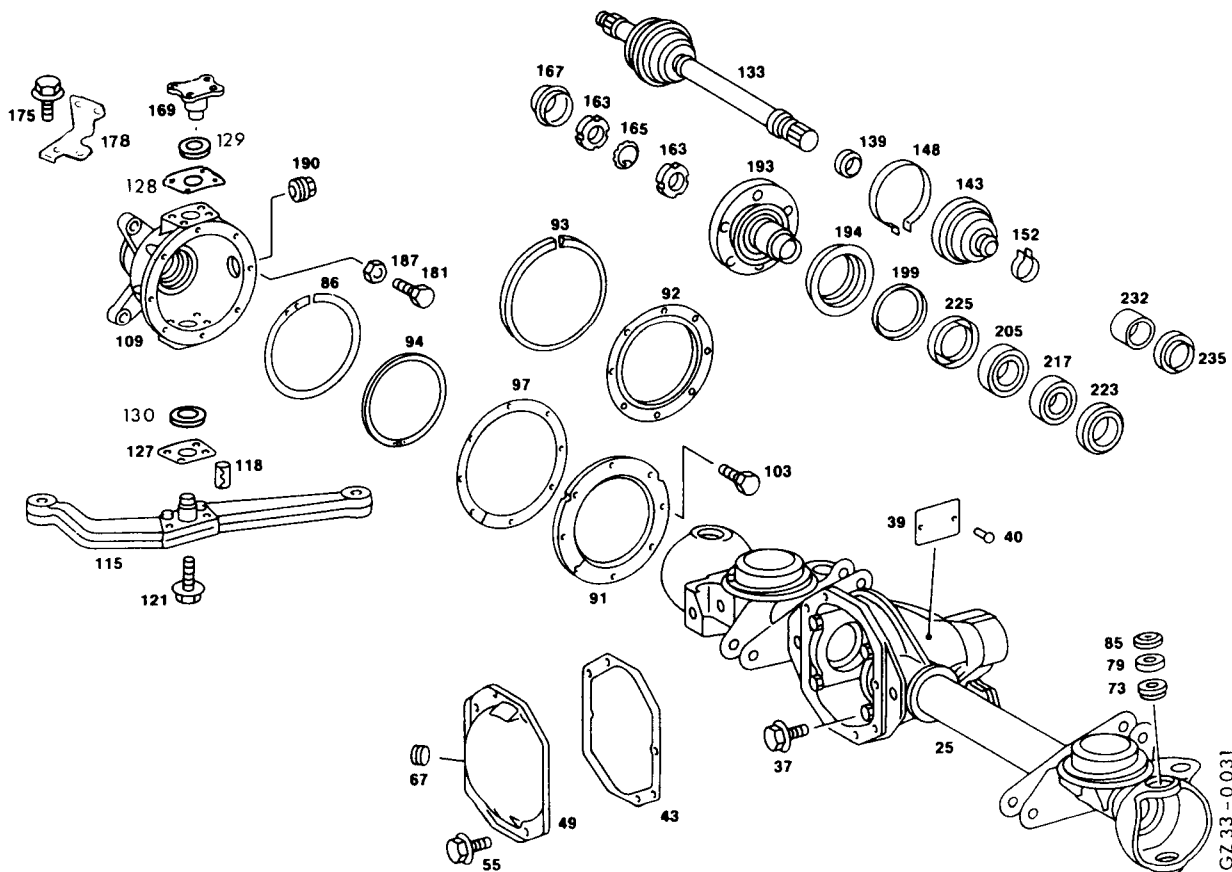

GZ.33-0031

Removal

1 Remove joint housing with drive shaft, refer to 5.1/1.

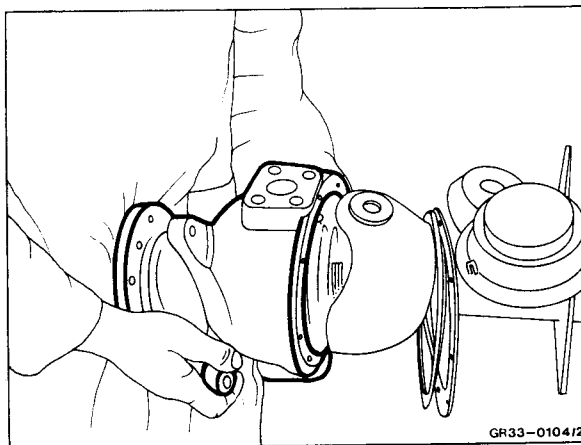

2 Bolt special tool to wheel hub.

 717 589 00 31 00

3 Clamp joint housing in vise.

4 Remove grease cap.

 116 589 22 33 00

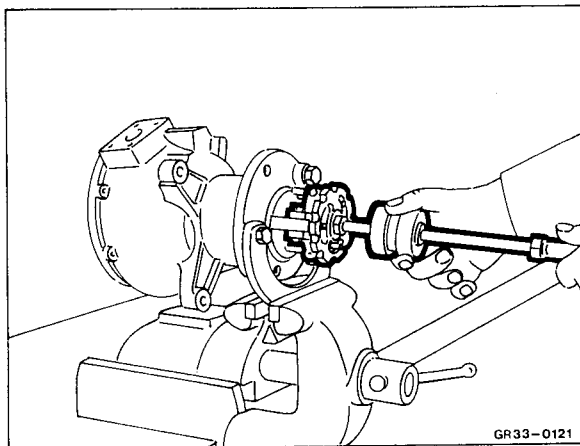

5 Release and unscrew external slotted nut.

6 Remove lock tab.

7 Unscrew inner slotted nut.

 463 589 00 07 00 (Type 463)

460 589 00 07 00 (Type 461)

460 589 02 07 00 (Type 461)

717 589 00 31 00

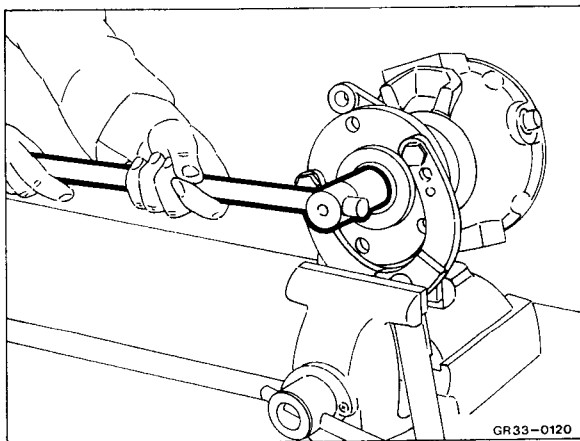

8 Pull out drive shaft.

Note: With anti-lock braking system (ABS) the measuring ring is not to be damaged.

9 Clean all parts, check, exchange as required.

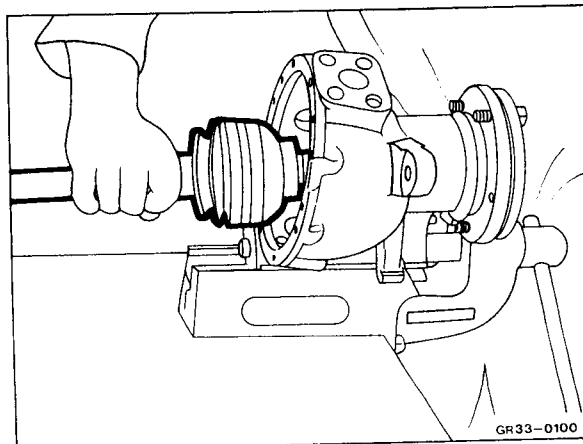

Installation

- 1 Push in drive shaft.

Note: With anti-lock braking system (ABS) the measuring ring is not to be damaged.

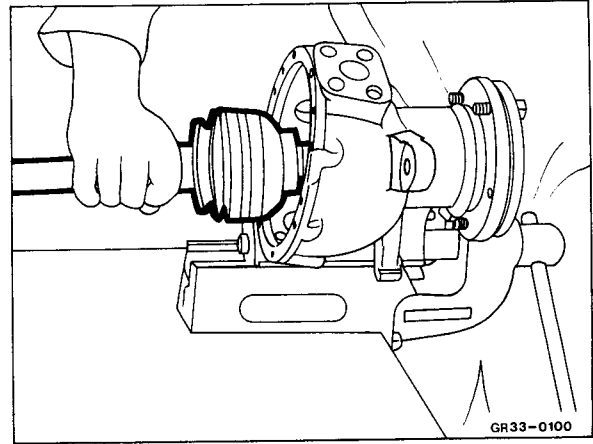

Note: Only use new slotted nuts and lock tabs.

- 2 Grease inner slotted nut at the contact surface to the wheel hub with lubricant no. 3 and tighten to 200 Nm, simultaneously turning the joint housing. (Settling and aligning of the bearing rollers). Release inner slotted nut until there is a clearance of approx. 0,1 mm (determine with dial gauge). Insert lock tab.

S 463 589 00 07 00 (Type 463)
 460 589 00 07 00 (Type 461)
 460 589 02 07 00 (Type 461)
 717 589 00 31 00

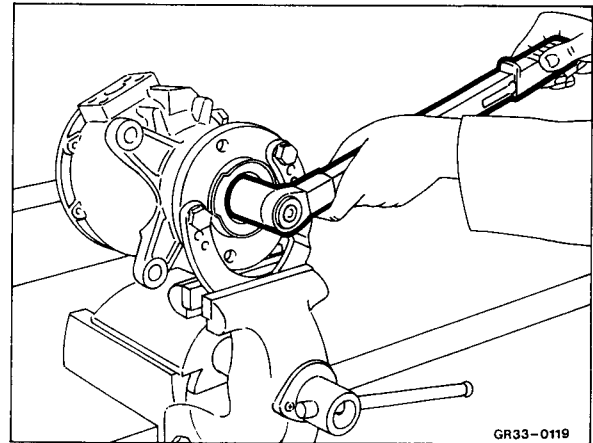

- 3 Sand outer slotted nut on contact surface to locktab with sandpaper. Grease slotted nut with lubricant no. 3 and tighten to 170 to 190 Nm.

S 463 589 00 07 00 (Type 463)
 460 589 00 07 00 (Type 461)
 460 589 02 07 00 (Type 461)
 717 589 00 31 00

Note: The chamfers of the slotted nuts must point to the lock tab side.

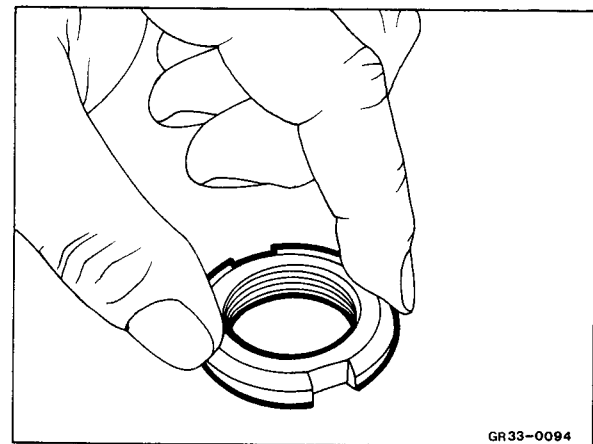

- 4 Check wheel bearing clearance.

Permissible wheel bearing clearance
 0,01 to 0,03 mm.

S 001 589 53 21 00
 363 589 02 21 00

Note: With used bearings, aim for wheel bearing clearance of 0,03 mm.

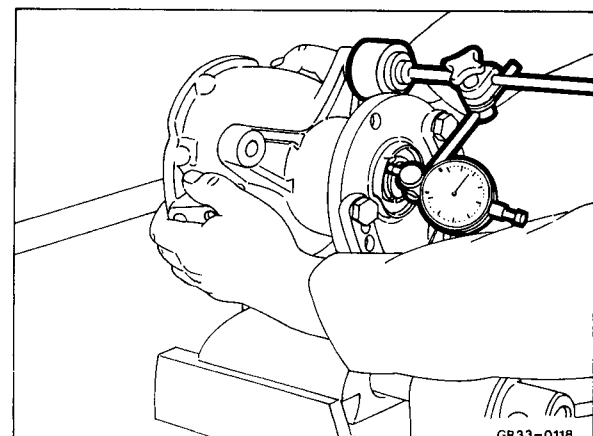

5 Secure external slotted nut.

6 Install grease cap.

 116 589 22 33 00

Note: Pack grease cap with lubricant no. 3.

7 Install joint housing with drive shaft, refer to 5.1/5.

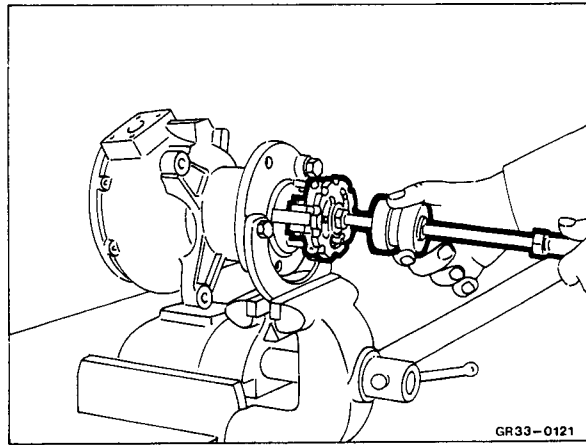

Special tools 

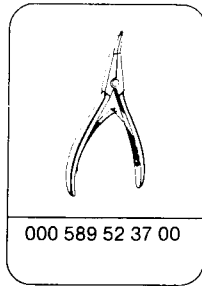
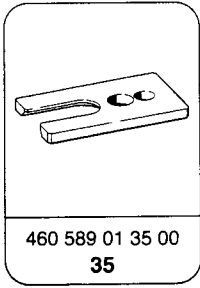

Expendable materials

Cons. No.	Designation	Part Number
1	Lubricant: Molycote	000 989 63 51

Input shaft

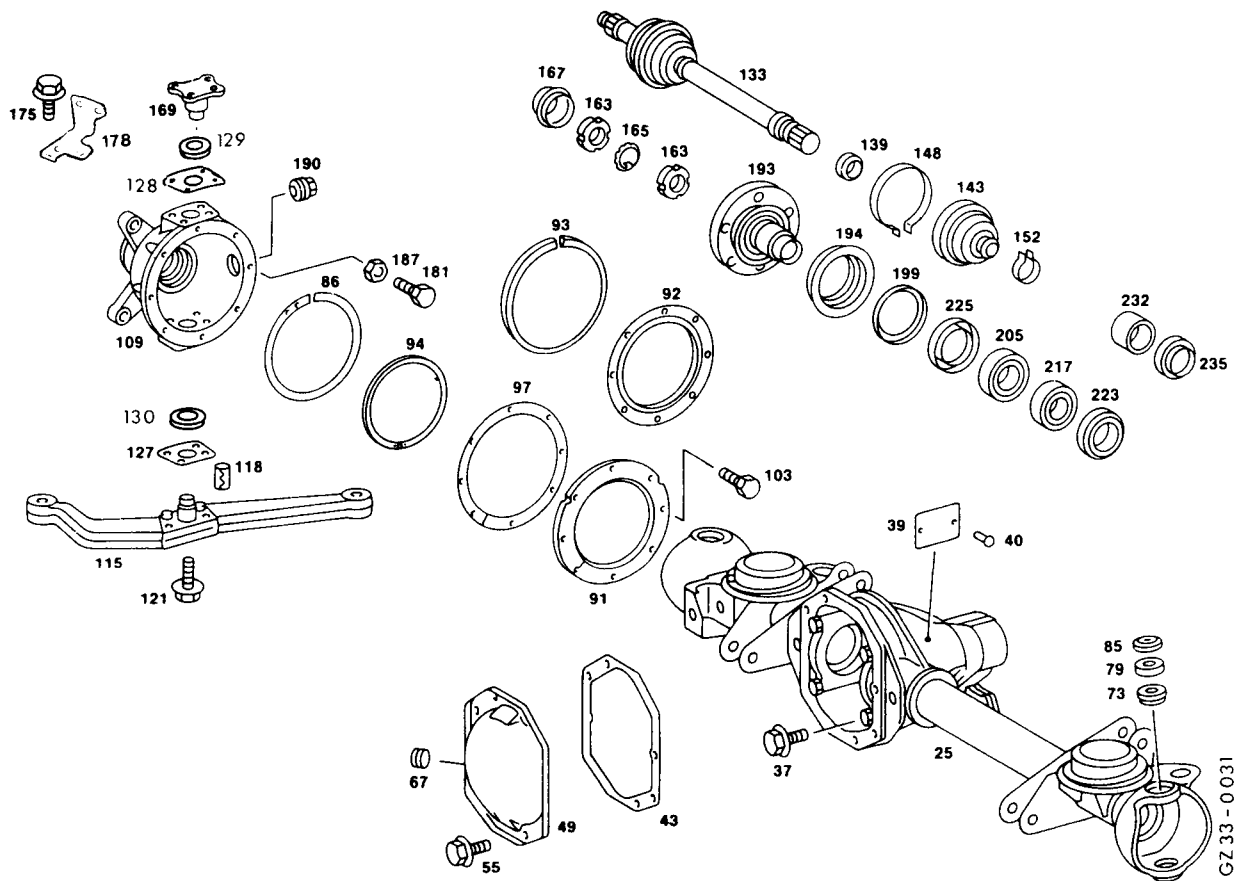

GZ 33 - 0031

Disassembly

1 Clamp joint in vice.

Note: With anti-lock braking system (ABS) the measuring ring is not to be damaged.

2 Remove both hose clamps and push back rubber gaiter.

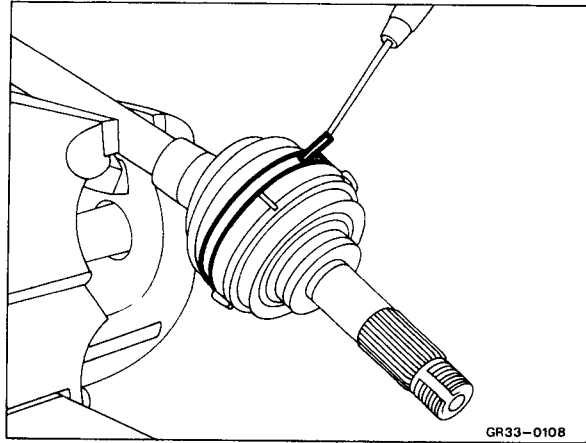

3 Press apart lock washer. Knock joint from drive shaft using a plastic hammer.

B 000 589 52 37 00

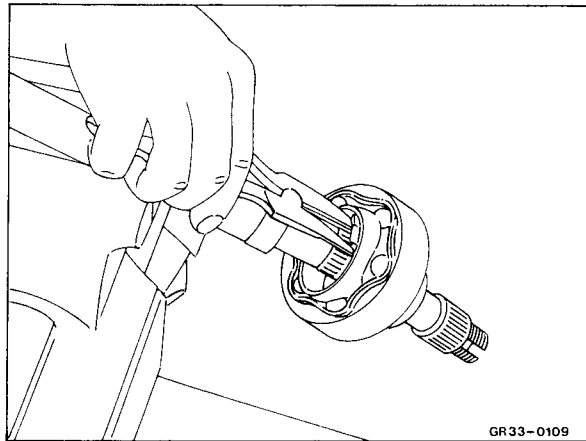

4 Detach joint.

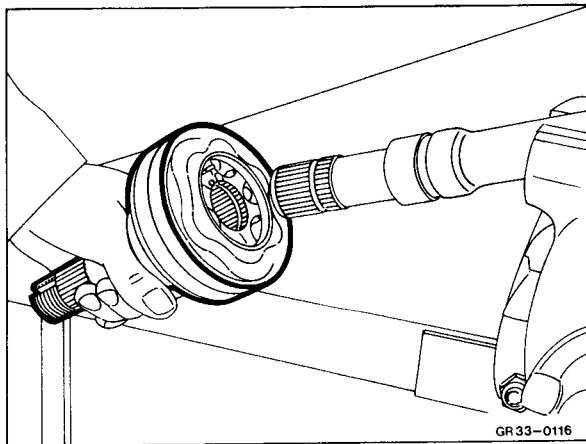

5 Remove bearing race.

B 460 589 01 35 00

6 Clean all parts, check, exchange as required.

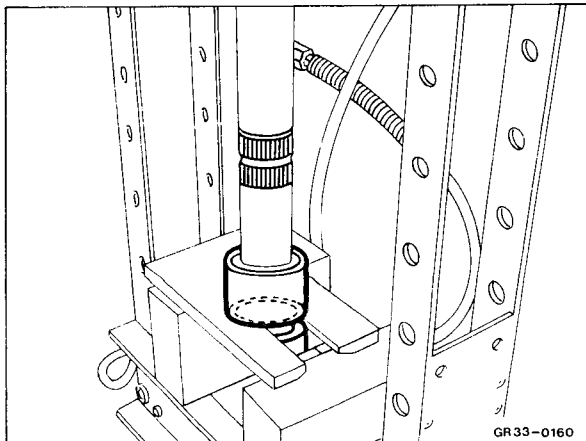

Assembly

1 Heat bearing race to 160 – 180 °C and install.

Note: With anti-lock braking system (ABS) the measuring ring is not to be damaged.

2 Fit rubber gaiter.

3 Pack joint with lubricant no. 1.

Capacity per joint 120 g.

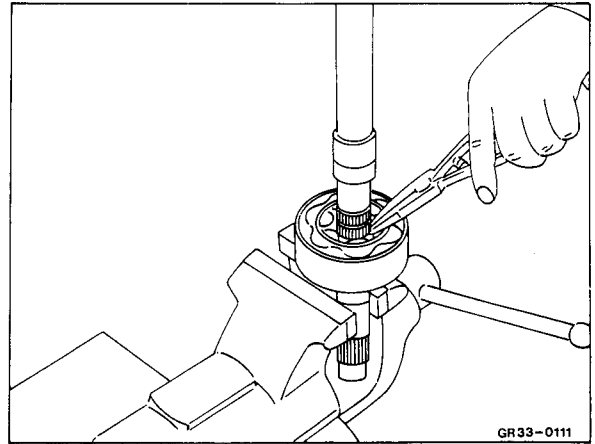

4 Slide joint on drive shaft.

5 Install drive shaft and secure.

Z 000 589 52 37 00

6 Install rubber gaiter and secure hose clamp.

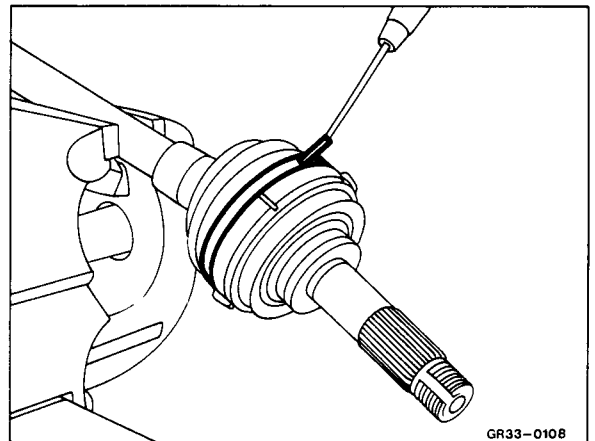

Setting values

Permissible wheel bearing clearance	mm	0,01 to 0,03 ¹⁾
Preload on the kingpins	mm	0,3 ± 0,05

1) With used bearings, aim for wheel bearing clearance of 0,03 mm.

Special tools

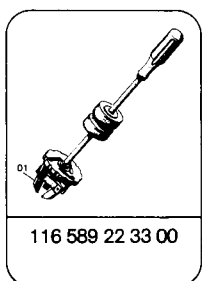
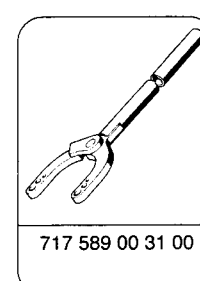
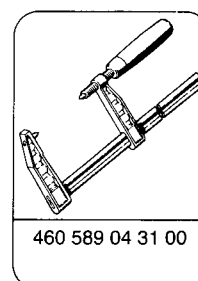
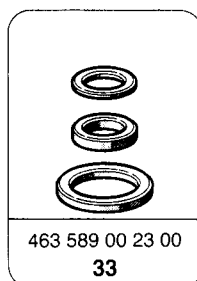
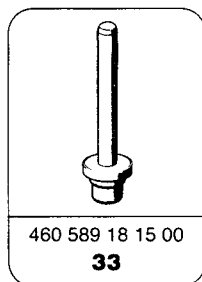
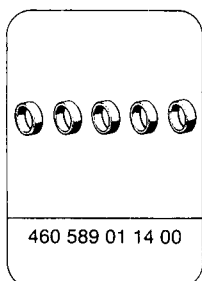

Expendable materials

Cons. No.	Designation	Part Number
3	Lubricant: multipurpose grease	commercially

Note: Only carry out adjustment if either the axle housing, joint housing or kingpin have been replaced or if the shims have been interchanged or lost.

The adjustment should be carried out with a **new** drive shaft.

Install axle shaft in the joint housing and tighten up to stop with a slotted nut.

Adjustment of the steering knuckle bearing

1 Insert corresponding guide ring from special tool in axle tube.

460 589 01 14 00

Note: Guide ring must slide onto bearing race of drive shaft without clearance.

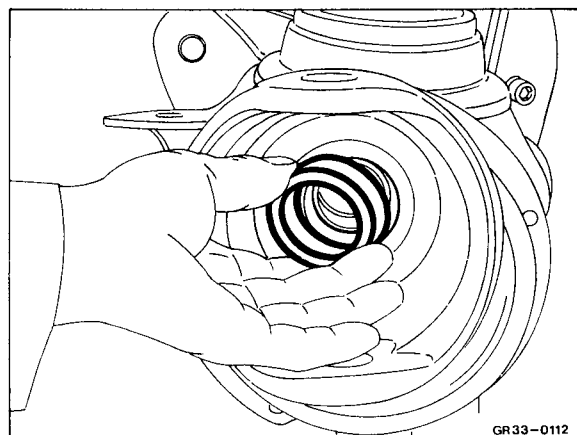

2 Centre track rod arm with blow with punch.

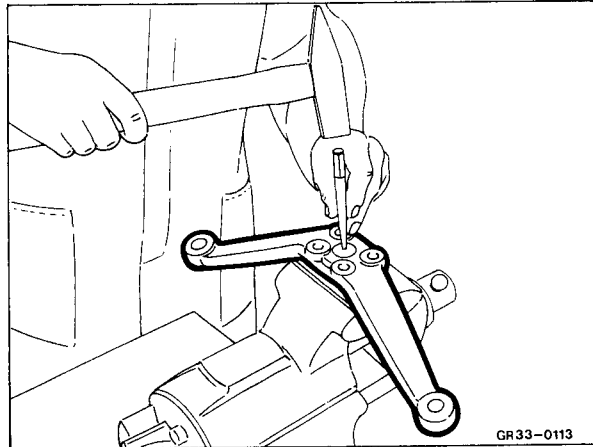



3 Install new tapered roller bearings with nilos ring.

4 Install joint housing with drive shaft, install upper kingpin **without** clamping sleeves and shims.

Kingpin bearing, lower

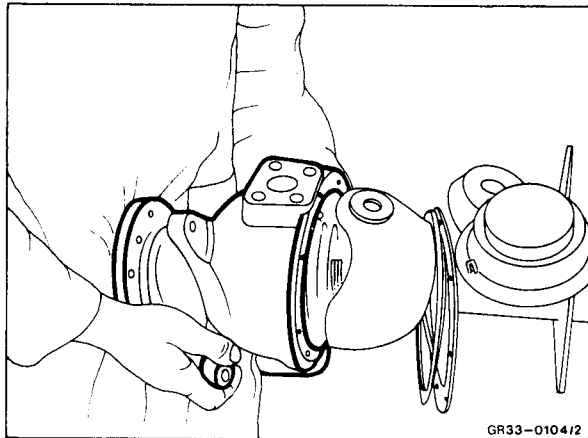
The lower kingpin has a tight fit over the last 5 mm in the joint housing. For measuring the washers to be inserted it is therefore necessary to insert a spacer ring of 6 mm between the bearing inner race and the kingpin, inside and a spacer ring of 4 mm between the steering knuckle arm and joint housing, outside.



 463 589 00 23 00

5 Compress kingpin and track rod arm until play is no longer present in the steering knuckle bearing.

 460 589 04 31 00

Note: Before measuring move towards the joint housing back and forth so that bearing seats.

6 With feeler gauge determine the distance between joint housing and kingpin or track rod arm and spacer ring (4 mm), write down the value.

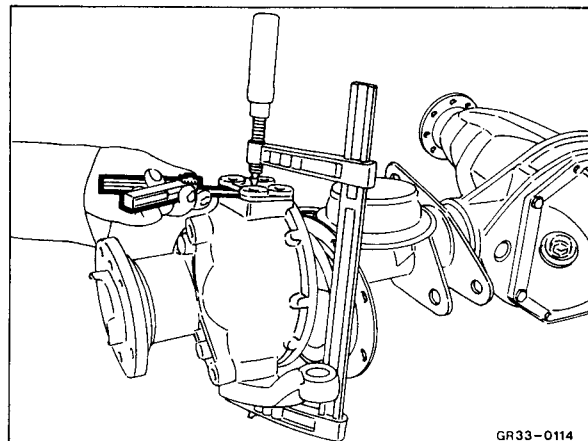

Example:

Measure steering knuckle at top A without washer

Gap "A"	=	1,05 mm
- preload	=	- 0,15 mm
Thickness of washer	=	0,90 mm

Measure steering knuckle at bottom B

Diff. adjusting ring	=	2,00 mm
(6 - 4 = 2 mm)		
Gap "B"	=	-1,10 mm
	=	0,90 mm
Preload	=	+0,15 mm
Thickness of washer	=	1,05

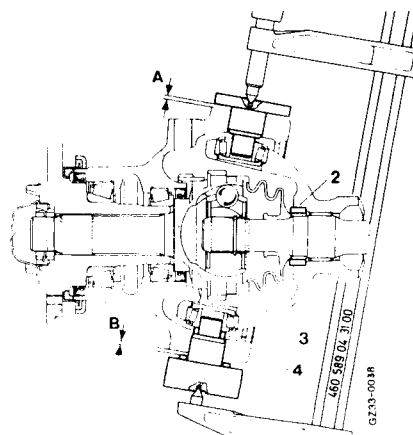

7 Remove joint housing with drive shaft.

Note: With anti-lock braking system (ABS) the measuring ring is not to be damaged.

8 Remove guide ring.

 460 589 01 14 00

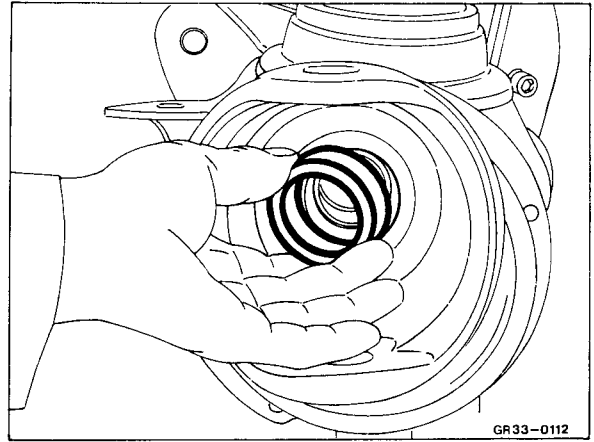

9 Coat new shaft seal with lubricant no. 3 and drive in flush.

 460 589 18 15 00

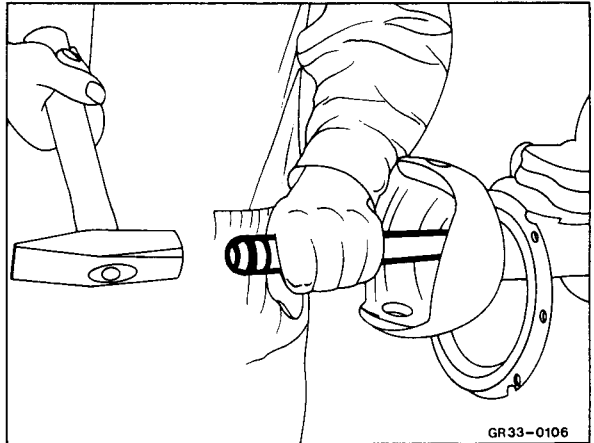

10 Clamp joint housing in vise.

 717 589 00 31 00

11 Remove the drive shaft installed for checking alignment, install old shaft again.

12 Adjust wheel bearing clearance, refer to 4.1/4.

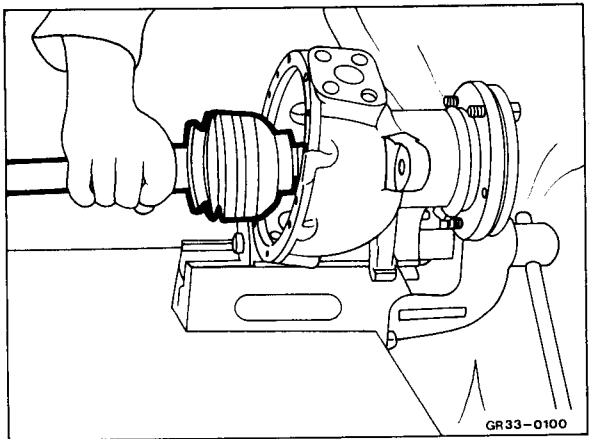

13 Fill grease cap with lubricant no. 3, install grease cap.

 116 589 22 33 00

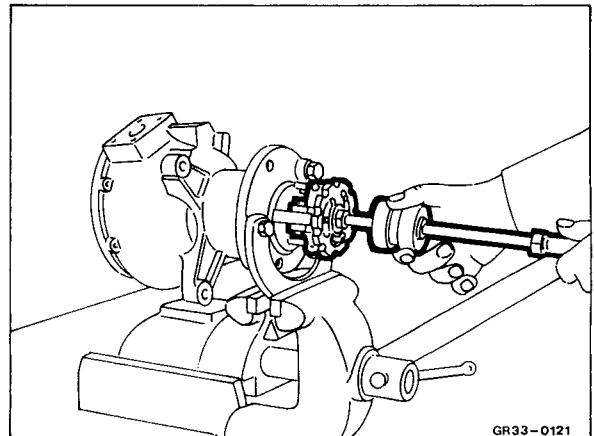

Setting values

Permissible wheel bearing clearance	mm	0,01 to 0,03 ¹⁾
Preload on the kingpins	mm	0,3 ± 0,05

1) With used bearings, aim for wheel bearing clearance of 0,03 mm.

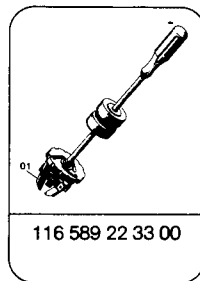
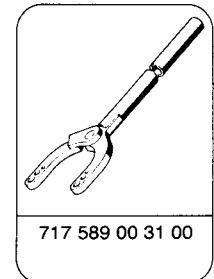
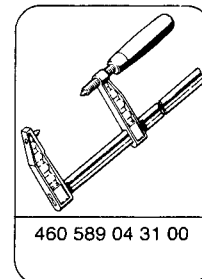
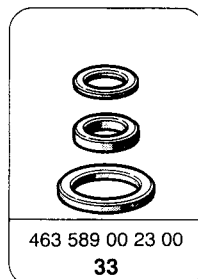
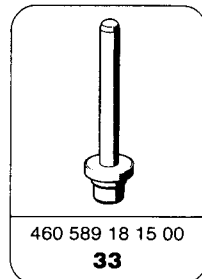
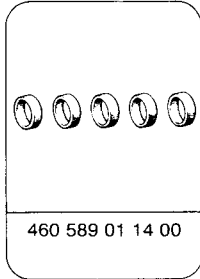
Special tools **Expendable materials**

Cons. No.	Designation	Part Number
3	Lubricant: multipurpose grease	commercially

Note: Only carry out adjustment if either the axle housing, joint housing or kingpin have been replaced or if the shims have been interchanged or lost.

The adjustment should be carried out with a **new** drive shaft.

Install axle shaft in the joint housing and tighten up to stop with a slotted nut.

Adjustment of the steering knuckle bearing

1 Insert corresponding guide ring from special tool in axle tube.

 460 589 01 14 00

Note: Guide ring must slide onto bearing race of drive shaft without clearance.

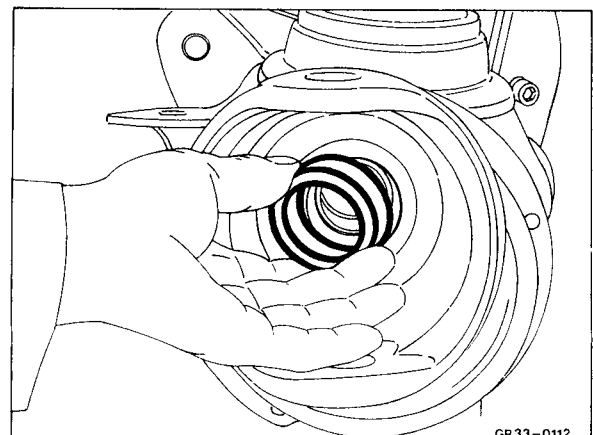

2 Centre lower kingpin with blow of centre punch.

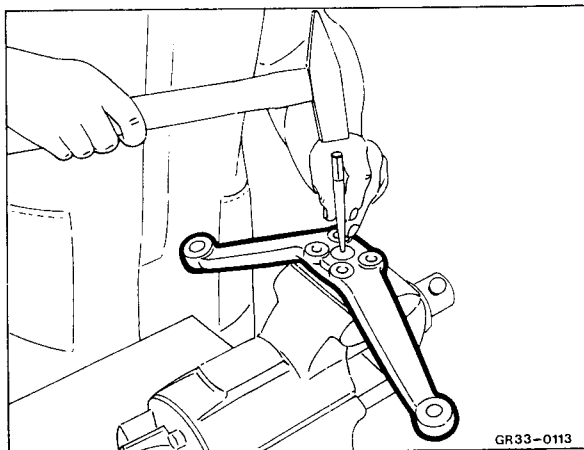

GR33-0113

3 Install new tapered roller bearings with nilos ring.

4 Install joint housing with drive shaft, install upper kingpin with 2 mm adjusting ring.

Kingpin bearing, lower

The lower kingpin has a tight fit over the last 5 mm in the joint housing. For measuring the washers to be inserted it is therefore necessary to insert a spacer ring of 6 mm between the bearing inner race and the kingpin, inside and a spacer ring of 4 mm between the steering knuckle arm and joint housing, outside.

 463 589 00 23 00

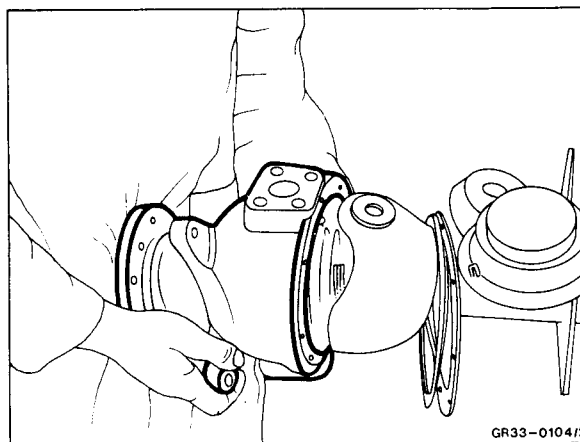

GR33-0104/2

5 Compress kingpin and track rod arm until play is no longer present in the steering knuckle bearing.

 460 589 04 31 00

Note: Before measuring move towards the joint housing back and forth so that bearing seats.

6 With feeler gauge determine the distance between joint housing and kingpin or track rod arm and spacer ring (4 mm), write down the value.

Example:

Measure steering knuckle **top A**

Adjusting ring	=	2,00 mm	
Gap „A“	=	-1,30 mm	
	=	0,70 mm	_____

Preload	=	+0,15 mm	_____
---------	---	----------	-------

Washer thickness	=	0,85 mm	_____
-------------------------	---	---------	-------

Measure steering knuckle **bottom B**

Diff. adjusting ring	=	2,00 mm	
(6 - 4 = 2 mm)			
Gap „B“	=	-1,10 mm	
	=	0,90 mm	_____

Preload	=	+0,15 mm	_____
---------	---	----------	-------

Washer thickness	=	1,05 mm	_____
-------------------------	---	---------	-------

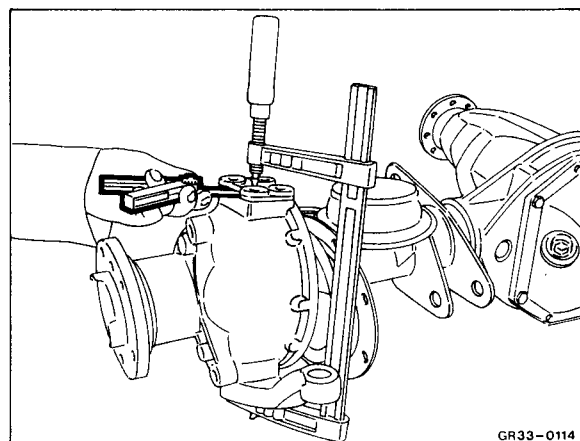

GR33-0114

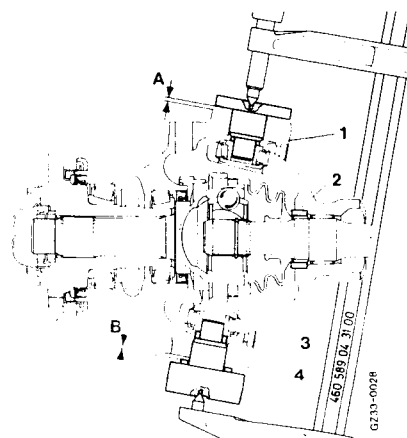

G273-0028

7 Remove joint housing with drive shaft.

Note: With anti-lock braking system (ABS) the measuring ring is not to be damaged.

8 Remove guide ring.

 460 589 01 14 00

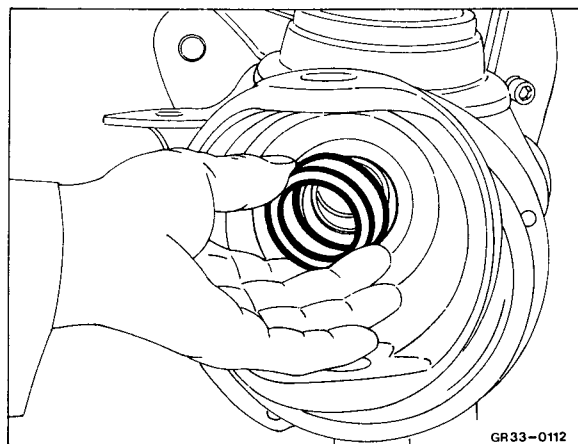

9 Coat new shaft seal with lubricant no. 3 and drive in flush.

 460 589 18 15 00

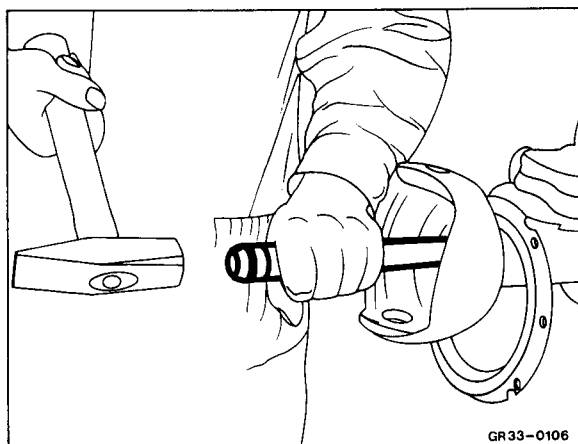

10 Clamp joint housing in vise.

 717 589 00 31 00

11 Remove the drive shaft installed for checking alignment, install old shaft again.

12 Adjust wheel bearing clearance, refer to 4.1/4.

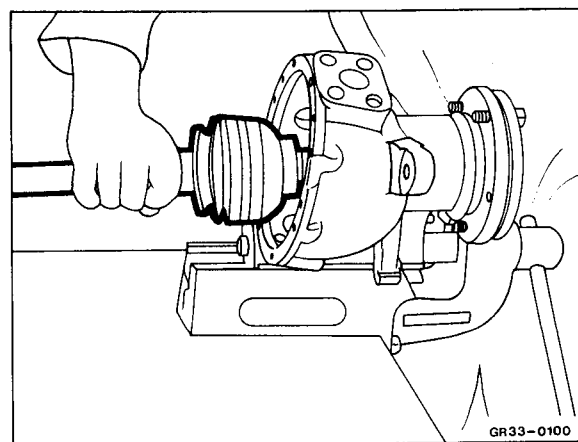

13 Fill grease cap with lubricant no. 3, install grease cap.

 116 589 22 33 00

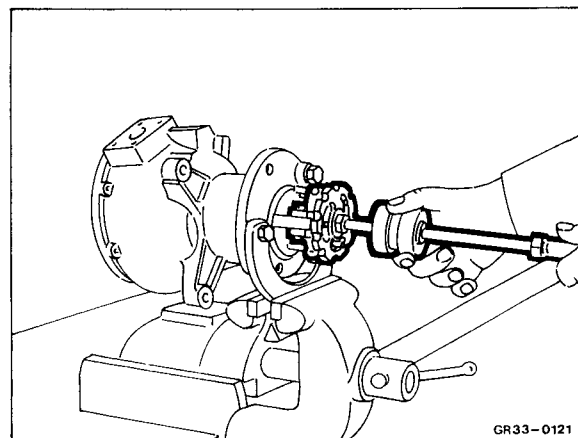

Special tools 

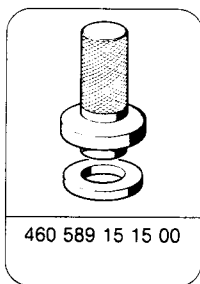

460 589 15 15 00

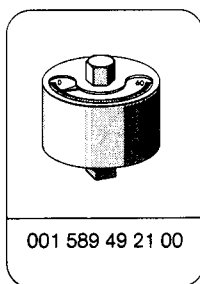

001 589 49 21 00

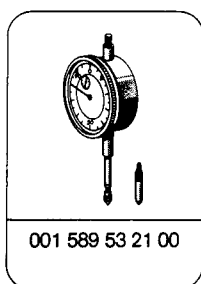

001 589 53 21 00

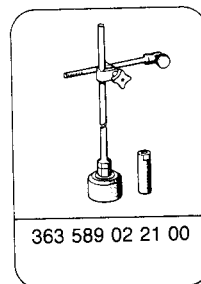

363 589 02 21 00

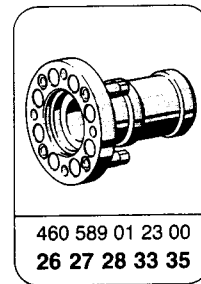

460 589 01 23 00
26 27 28 33 35

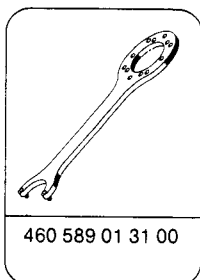

460 589 01 31 00

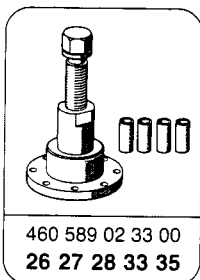

460 589 02 33 00
26 27 28 33 35

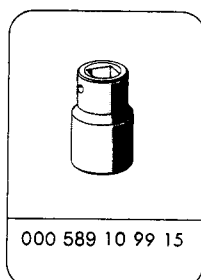

000 589 10 99 15

Tool for self-assembly

Base plate for measuring stand

Material: St 37

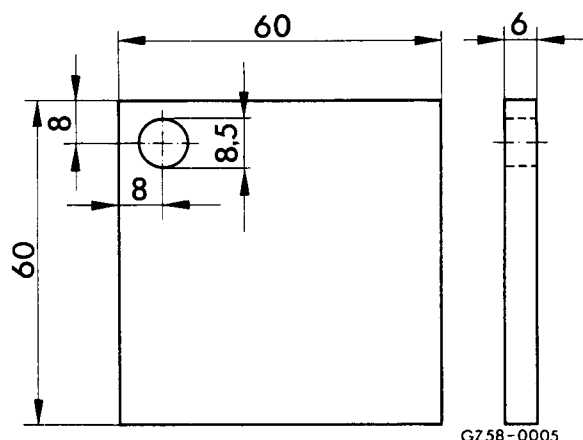

Expendable materials

Cons. No.	Designation	Part Number
2	Sealing compound: Omnifit FD 10	002 989 00 20 10
3	Lubricant: multipurpose grease	commercially

Bevel gear

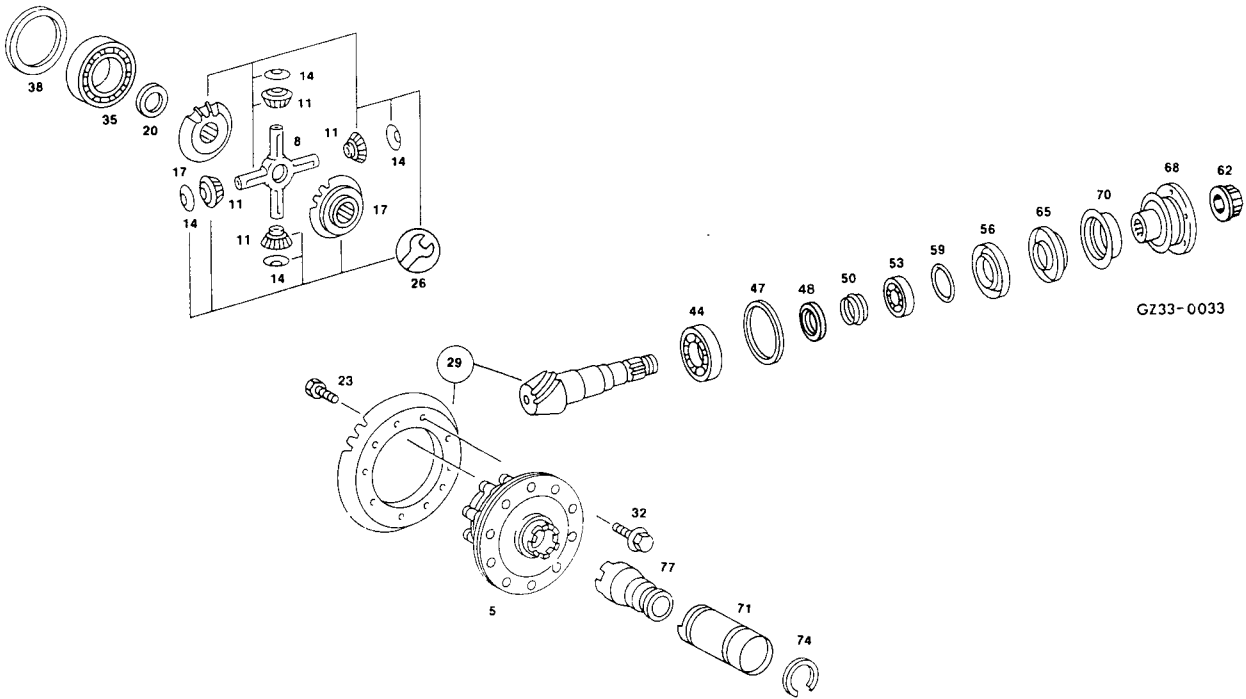

Exchange

1 Measure friction torque of entire axle (without wheels) the flange with special tools each time before the flange and sealing rings are disassembled. Note measured friction torque.

 000 589 10 99 15
001 589 49 21 00

Note: Make sure that the brake is released.

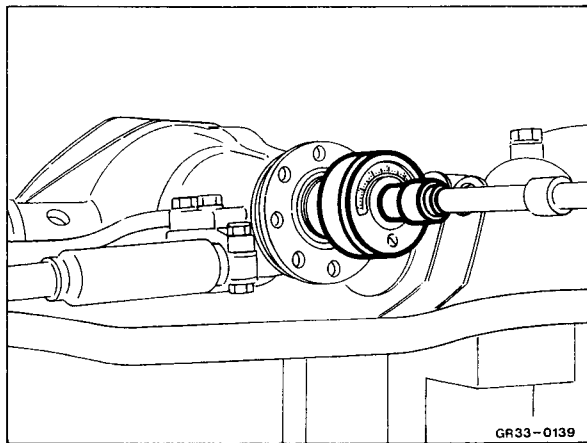

2 Mark flange to bevel gear (due to wobble).

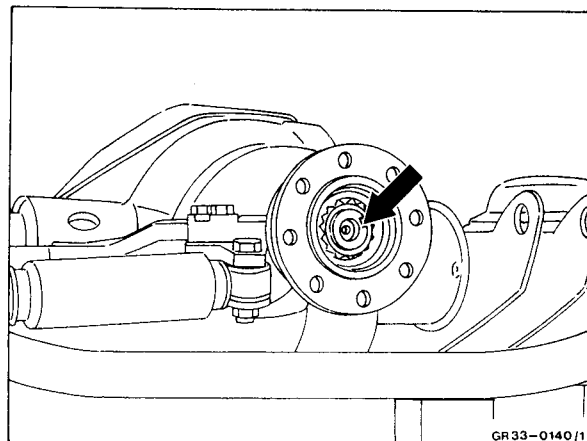

3 Remove nut.



000 589 10 99 15
460 589 01 31 00

Note: Release nut.

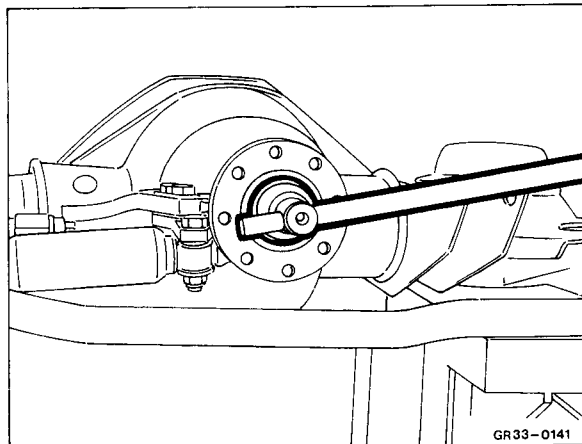

4 Remove flange.



460 589 02 33 00

Note: Do not remove flange by hitting with hammer under any circumstances, this would damage the bearings.

5 Check flange for damage and scoring.

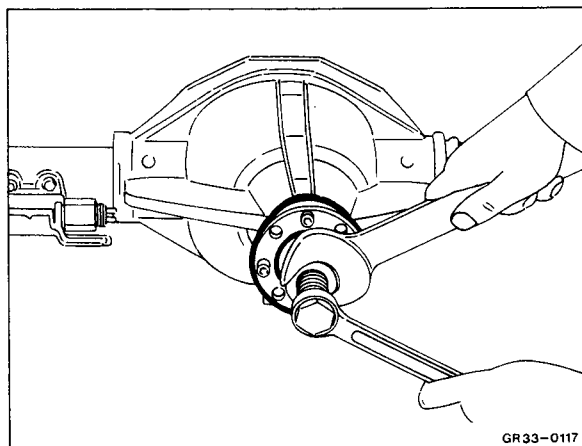

6 Remove sealing rings.

7 Install new sealing rings.



460 589 15 15 00

Note: Prior to installation of sealing rings, pack space between dust and sealing lips with lubricant no. 3, lightly grease the lips. Coat sealing rings at the outer periphery with sealing compound no. 2.

Install inner sealing ring with washer and outer sealing ring without washer of special tool.

Note:

- Install sealing rings with outer rubber coating without sealing compound.
- Pay attention to any possible springing off of the garter springs. Grease garter springs.

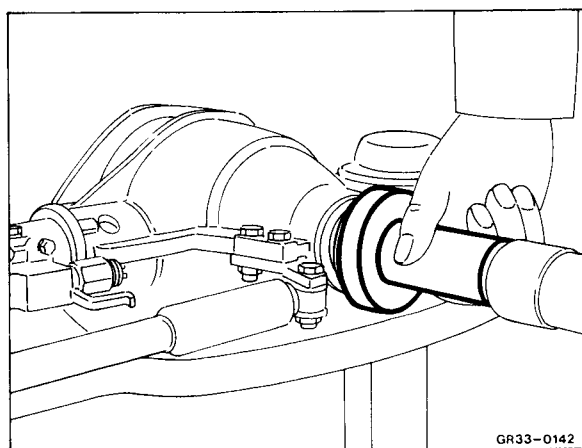

8 Install flange.

Note: Pay attention to marking.

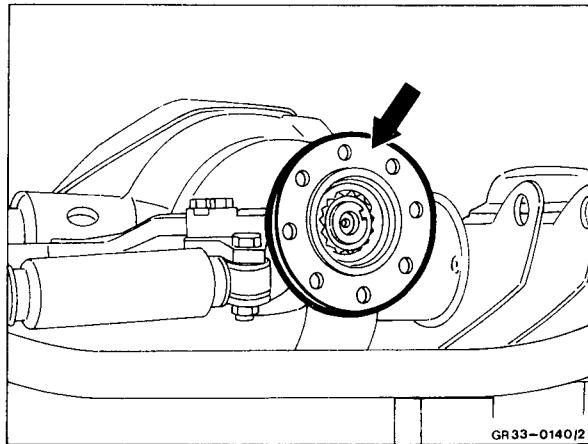

9 Install new nut.

10 Measure friction torque.

 000 589 10 99 15
001 589 49 21 00

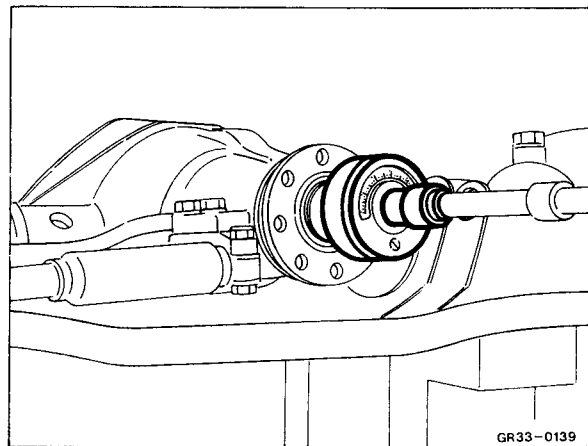

11 Install new nut. Alternately tighten slightly. Measure friction torque until the friction torque measured in point 1 is reached. The friction torque to be adjusted should be **0,5 Nm** higher than the value measured in point 1.

 000 589 10 99 15
460 589 01 31 00

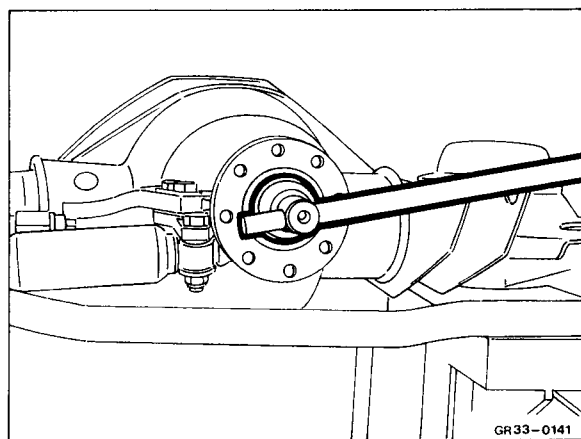

Note: If the nut is tightened excessively, the compressed ring is compressed too much. For this reason the bevel gear must be removed, the compressed ring replaced and the bevel gear adjusted again, refer to 8.1/1.

- 1 Shim
- 2 Ring
- 3 Oil retainer (only in model 463)
- 4 Compressed ring
- 5 O-ring
- 6 Radial sealing ring
- 7 Radial sealing ring
- 8 Nut
- 9 Flange

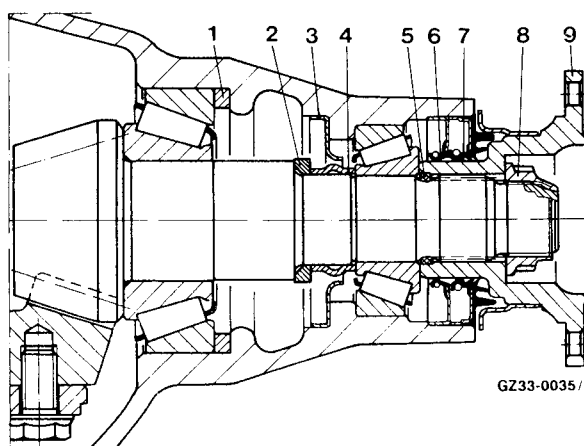

12 Prepare measuring plate according to drawing and secure to axle housing.

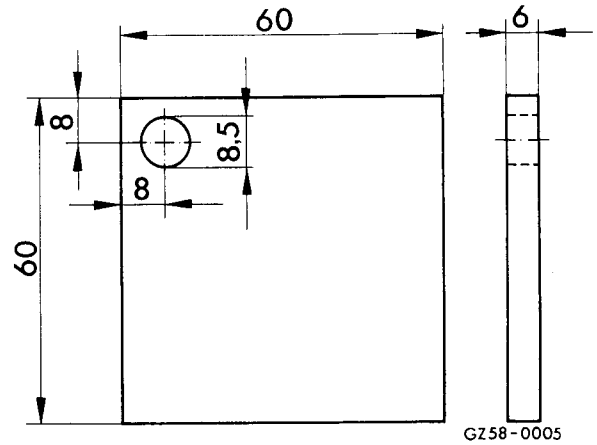

13 Check concentricity deviation on flange by means of special tool.

Total concentricity deviation < 0,07 mm

 001 589 53 21 00
 363 589 02 21 00
 460 589 01 23 00

Note: Once the dimension of 0,07 mm is exceeded, detach the flange. Turn the flange and install again.

- 180° after first measuring procedure
- 90° after second measuring procedure
- 180° after third measuring procedure

This procedure is called "matching" and is to be repeated max. 3 times. If the specified value is not attained using this method, replace the flange.

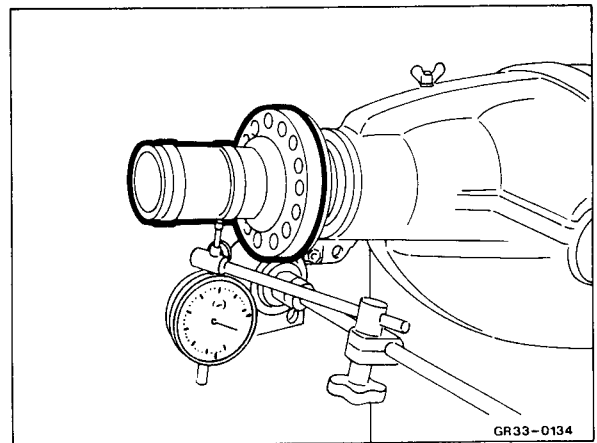

14 Secure nut.

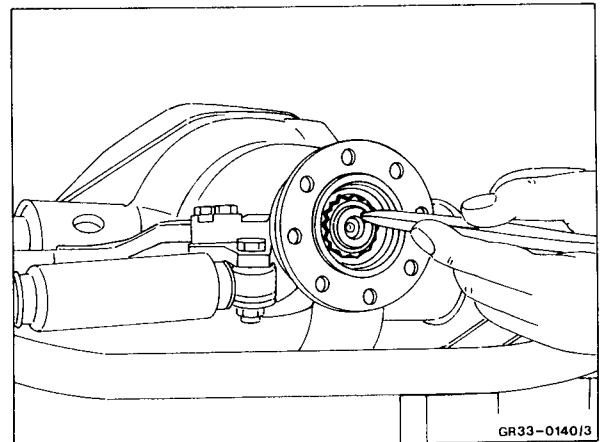

Note: Axially shear off lock collar of nut and bend in to base of groove so that the tab rests against the left flank of the locking groove.

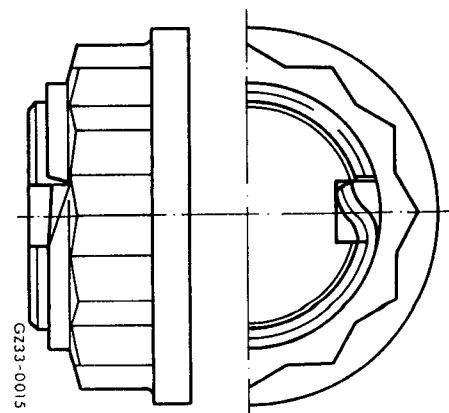

Setting values

Backlash	mm	0,10 to 0,15
Friction torque ring gear (pretension)	kg	4,0 ± 0,5

Special tools 

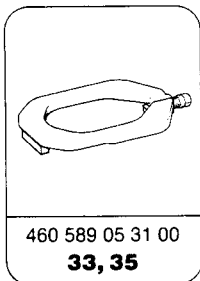
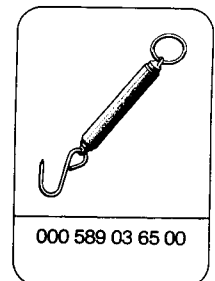
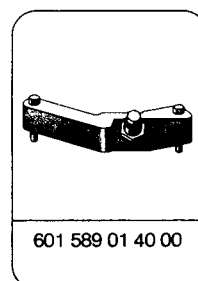
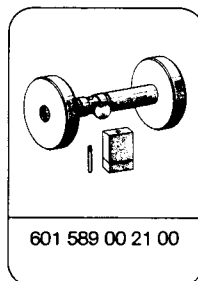
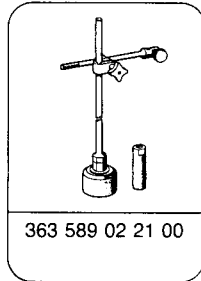
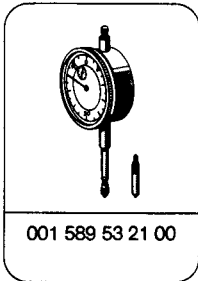

Front axle – Tightening torques

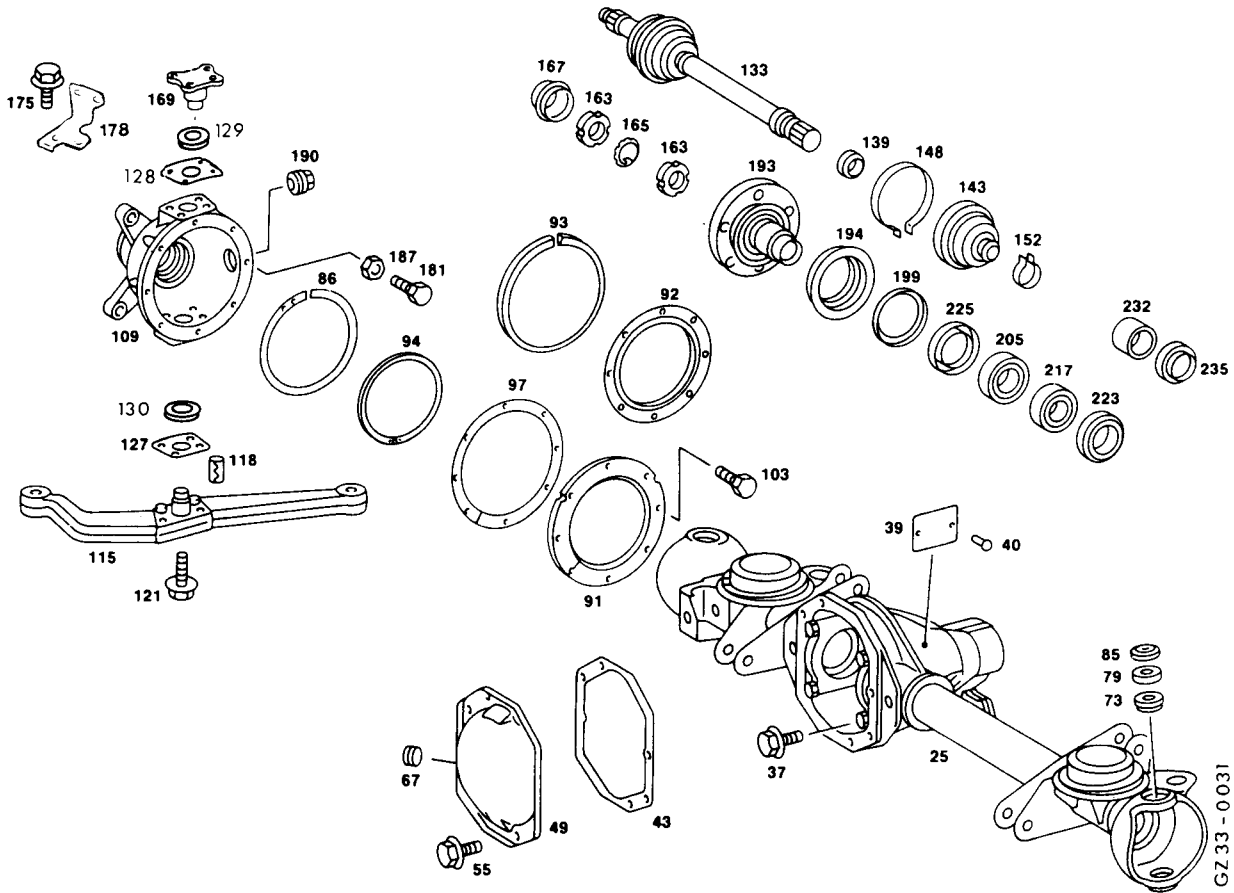

GZ33-0031

Fig. no.	Designation	Thread	Nm
37	Bearing cap to axle housing	M 10 x 80 – 10.9	65 to 75
55	Cover to axle housing	M 8 x 16 – 10.9	60 to 70

Removal

- 1 Unscrew and remove cover.
- 2 Remove joint housings, refer to 5.1/1.

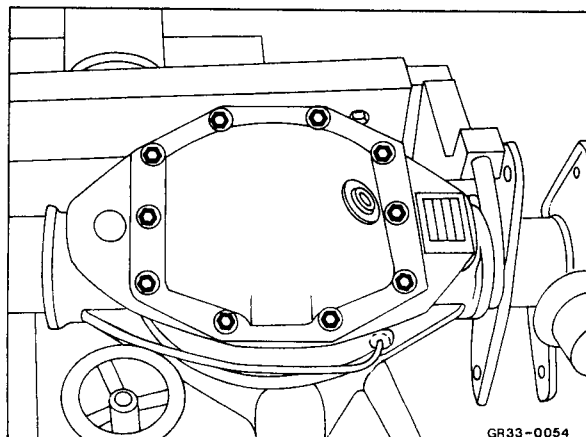

GR33-0054

3 Remove bearing cap.

Note: Mark bearing cap, shims and outer tapered bearing races.

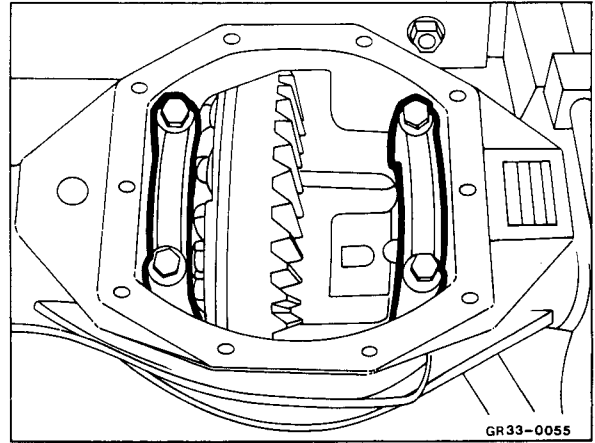

4 Mount special tool on axle housing and tighten until differential can be removed.

 460 589 05 31 00

5 Clean all parts, check, exchange as required.

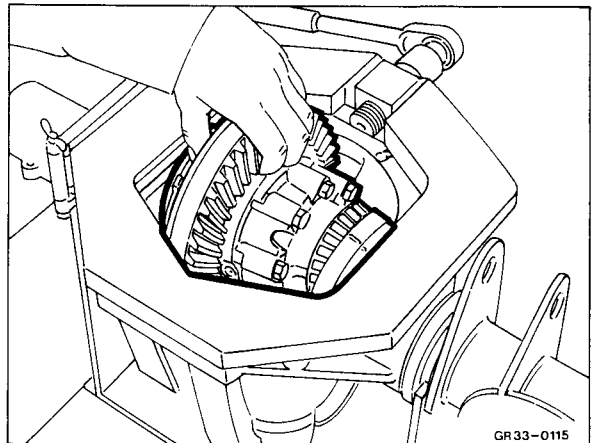

Installation

Note: If new parts have been installed in the differential, the shim rings must be remeasured.

1 Insert special tool in axle housing and measure gap with feeler gauge. The distance results from addition of 163,8 (dimension of special tool) plus thickness of feeler gauge.

 601 589 00 21 00

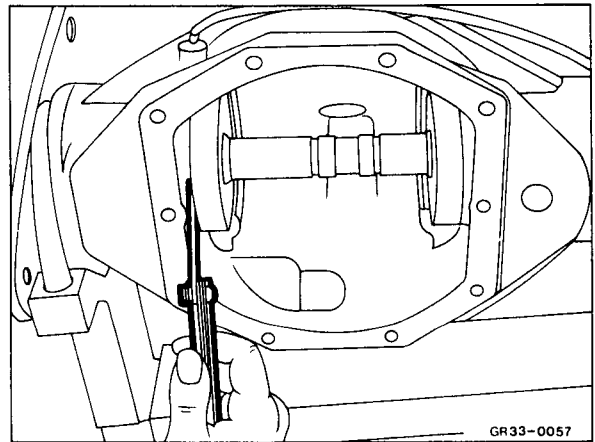

2 Measure distance from shim ring to shim ring on even plate. This dimension should be slightly greater (approx. 0,16 mm) than the distance measured in item no. 1 so that pretension is present on the differential bearing when installed in the axle. Select corresponding shim rings. Shim rings are available in thicknesses from 4,90 to 6,08 mm in graduations of 0,02 mm.

Note: When measuring, we recommend using the shim rings installed before.

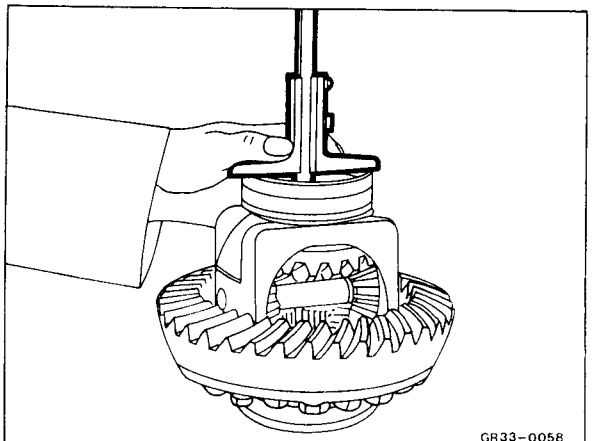

3 Mount special tool on axle housing and tighten.

 460 589 05 31 00

4 Install differential with the determined shim rings in axle housing.

Note: Install thinner shim ring on ring gear side marked with arrow to achieve the required backlash.

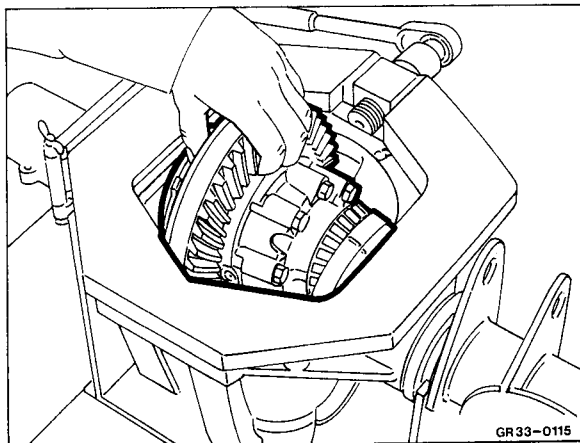

Note: Turn ring gear several times and with a few hammer blows on bearing cover and ring gear provide alignment and seating of the bearing rollers.

5 Wind a cord around the differential housing several times and measure traction force. The correct friction torque (preload on differential bearing) is present when the traction force is 4 kg. The specified friction torque can be attained by selecting the proper shim rings.

 000 589 03 65 00

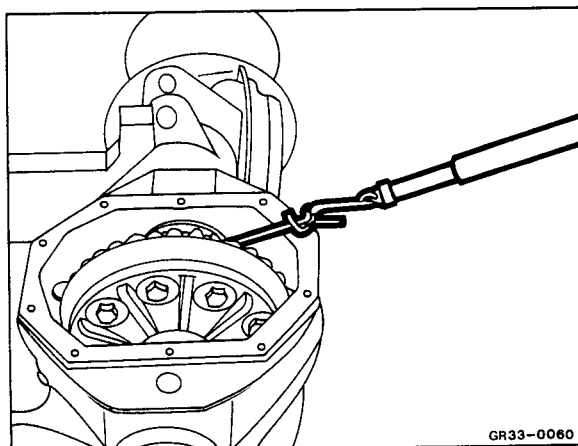

6 Check backlash.

Note: The backlash can be changed by installing shims. If a thinner shim is installed on one side of the differential housing, an equivalently thicker shim must be installed on the opposite side to maintain the preload on the differential bearing

 001 589 53 21 00
363 589 02 21 00

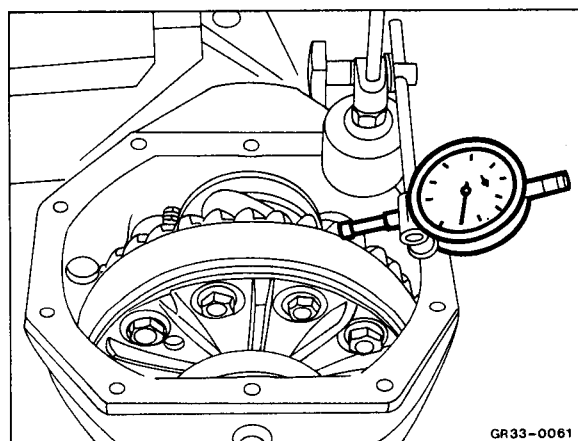

7 Position bearing cap (observe marking) and tighten bolts to 65 to 75 Nm.

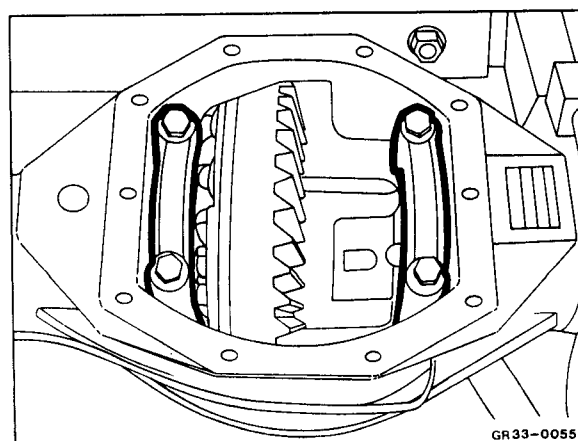

Check contact pattern

The ring gear and drive pinion are machined to production tolerances which assure that the adjustment of basic dimension and backlash are sufficient for installation. However it is recommended to check the contact pattern of the ring gear and pinion. Coat two teeth offset 180° on the ring gear with ink. Bolt special tool onto the rear axle housing and press against the ring gear, then turn the drive pinion back and forth.

 601 589 01 40 00

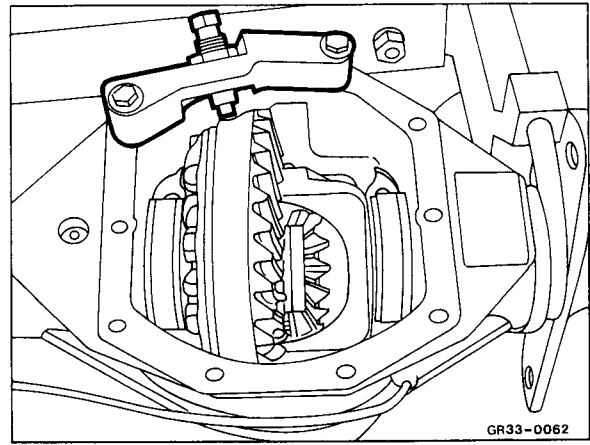
**Contact pattern on ring gear under load (ring gear braked)****Correct tooth bearing pattern**

In the practice such an ideal contact pattern cannot be achieved. However it is important that the contact pattern does not touch the outer edge of the tooth at any point.

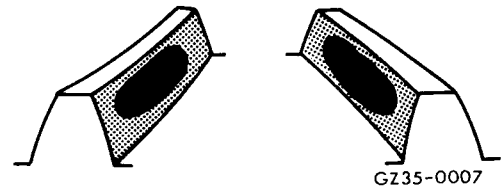
**Contact at tip of tooth (incorrect)**

Remedy: Reduce the installation distance (basic dimension) of the drive pinion slightly and simultaneously increase slightly the installation distance of the ring gear so that the teeth of the ring gear do not engage as deeply into the teeth of the drive pinion let so that the correct backlash is maintained.

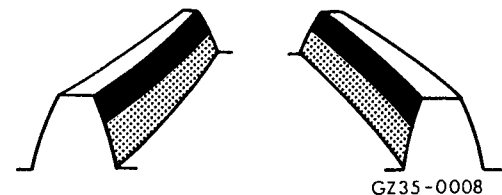
**Contact at base of tooth (incorrect)**

Remedy: Increase the installation distance (basic dimension) of the drive pinion slightly and simultaneously reduce slightly the installation distance of the ring gear so that the teeth of the ring gear engage more deeply into the teeth of the drive pinion so that the correct backlash is maintained.

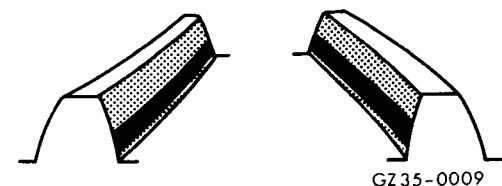

8 Install joint housings, refer to **5.1/1**.

9 Install front axle cover, tighten bolt to 60 to 70 Nm.

Note: Do **not** install gasket 601 351 00 80 with sealing compound.

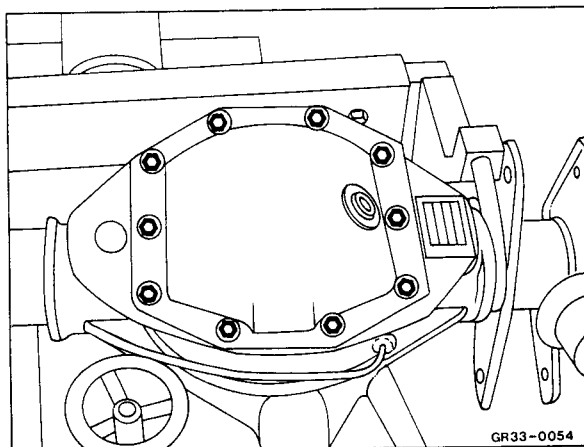

A. With differential lock

Setting values

Friction torque for turning complete balance	Nm	20 to 40
----------------------------------------------	----	----------

Special tools 

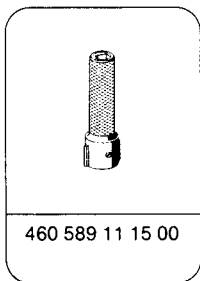

460 589 11 15 00

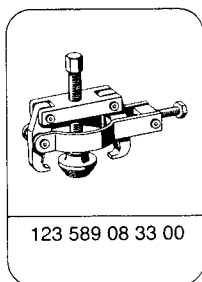

123 589 08 33 00

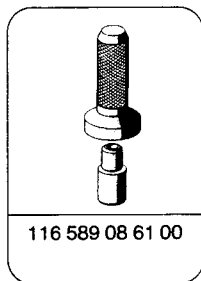

116 589 08 61 00

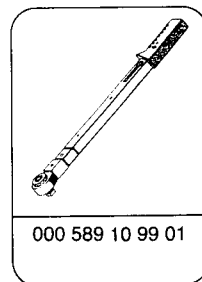

000 589 10 99 01

Differential – Tightening torques

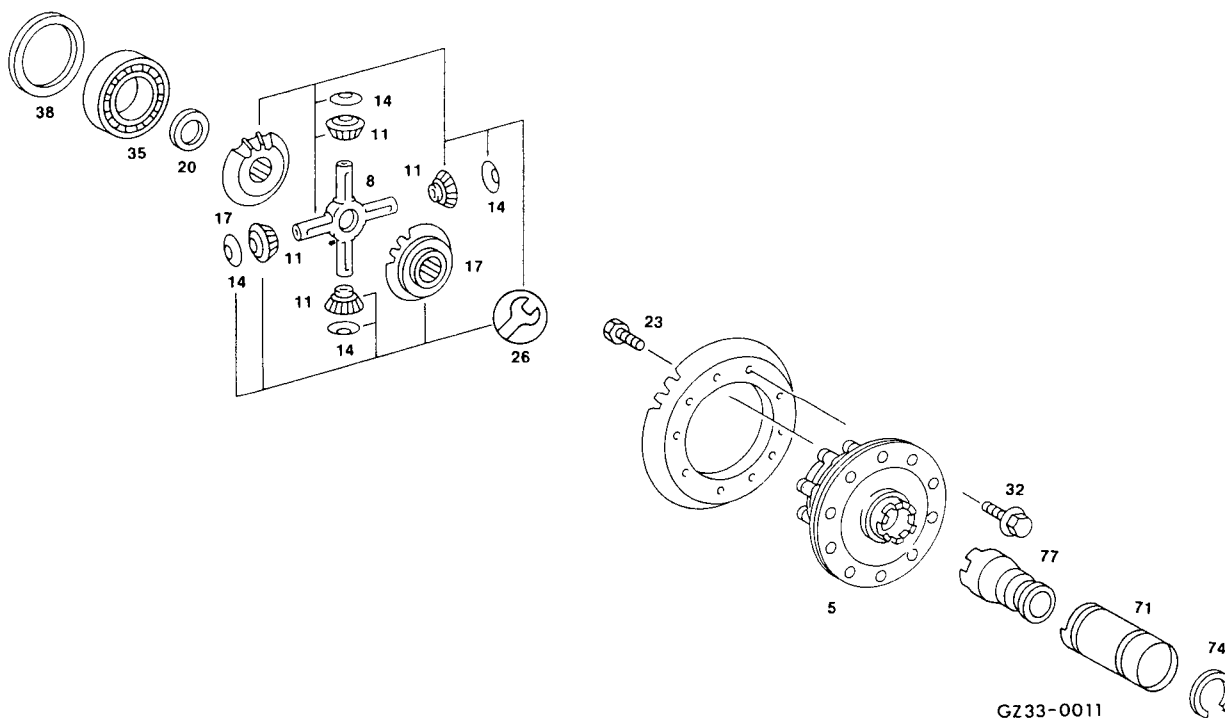

GZ33-0011

Fig. no.	Designation	Thread	Nm
32	Ring gear to differential housing	M 12 x 1 – 12.9	170 to 190
–	Cover to differential	M 8 x 16 – 10.9	40 to 45

Disassembly

1 Detach ring gear.

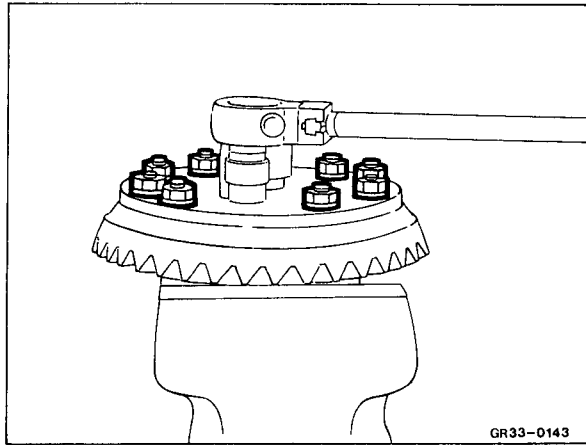

2 Remove both tapered roller bearings.

 123 589 08 33 00

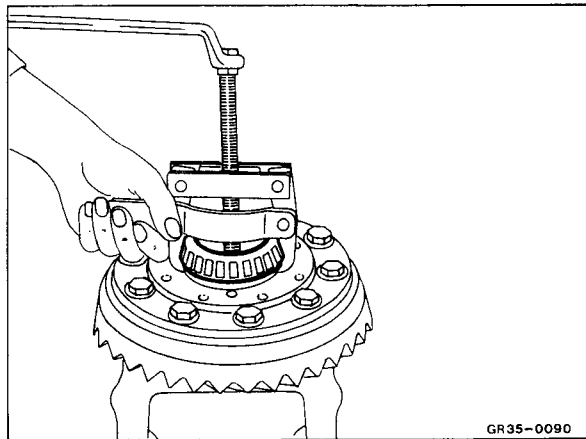

3 Remove cover of the differential.

Note: Mark relative positions of spherical washers, differential bevel gears as well as differential spider towards each other and towards the housing.

Note: Mark cover to the differential housing.

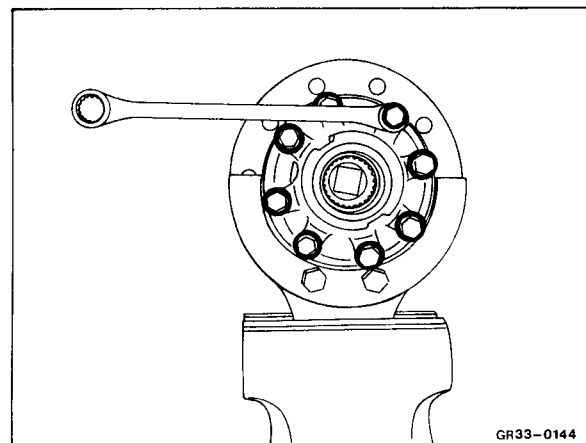

4 Remove side gear and thrust washer.

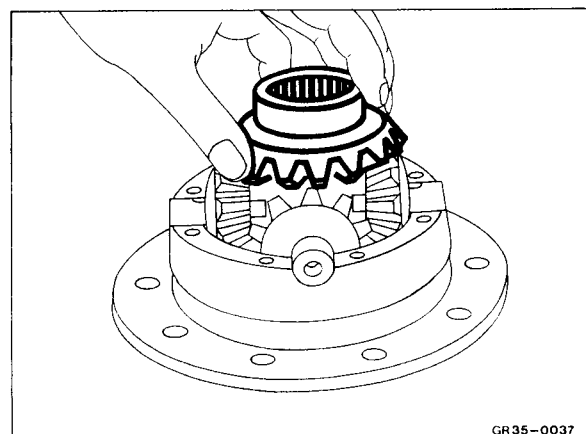

5 Remove differential spider with differential planet wheels.

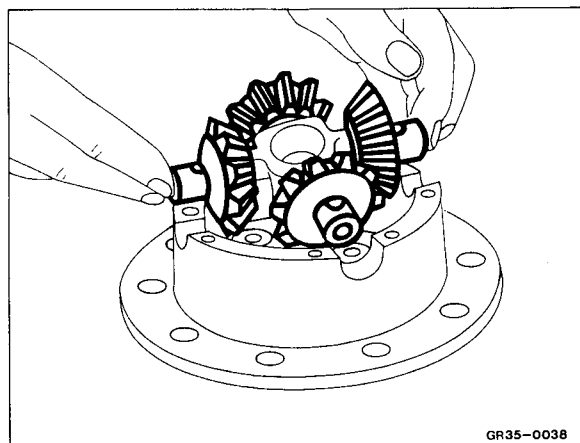

GR35-0038

6 Remove differential planet wheels with spherical washers.

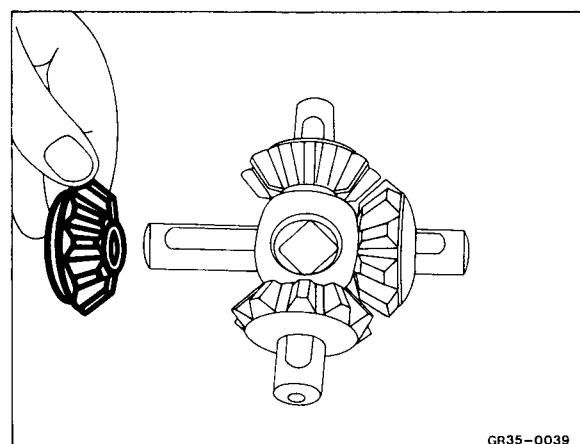

GR35-0039

7 Remove second side gear and shim ring.

8 Clean all parts, check, exchange as required.

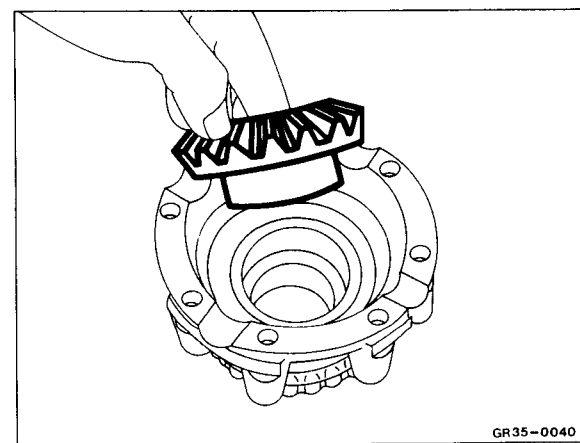

GR35-0040

Assembly

1 Insert shim ring and side gear.

Note: Groove on shim ring must point toward side gear.

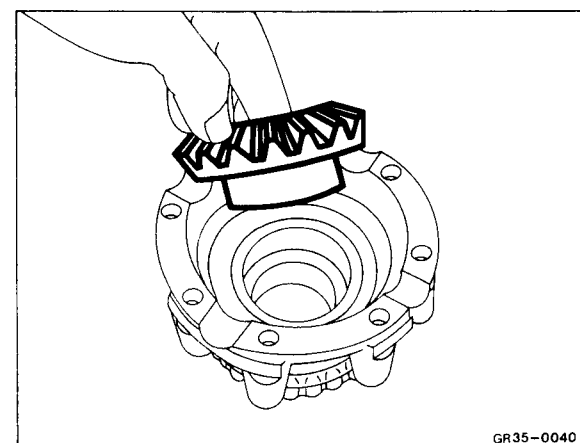

GR35-0040

2 Install differential pinions with spherical washers on differential spider.

3 Mount differential spider.

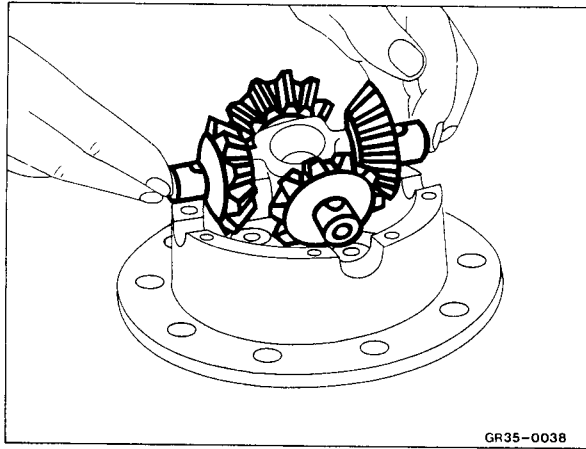

4 Mount second side gear with shim ring on differential spider.

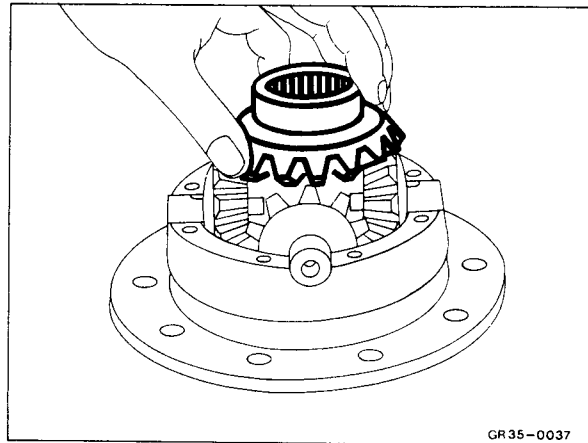

5 Mount cover on differential.

Note: The identification numbers must be above one another (identical numbers).

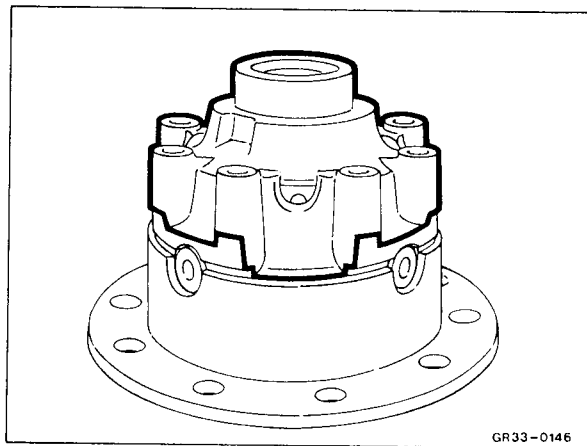

6 Tighten bolts to 40 to 45 Nm.

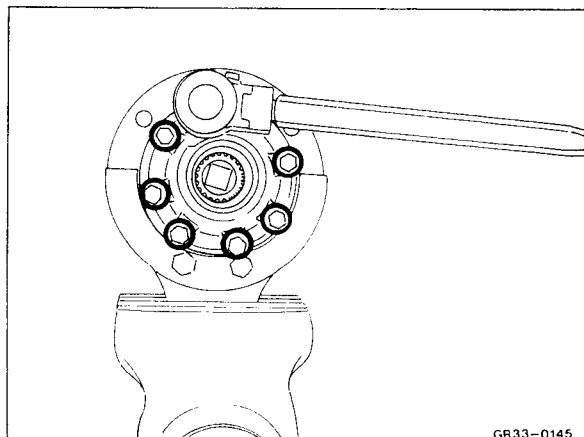

7 Check friction torque on both side gears using special tools.

Permissible friction torque: 20 to 40 Nm.

Note: The friction torque can be adjusted by inserting thrust washers with different thicknesses.

 460 589 11 15 00

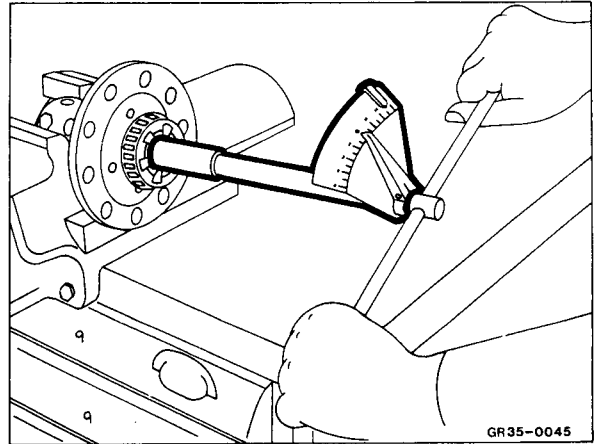

8 Heat both tapered roller bearings to approx. 80°C and fit.

 116 589 08 61 00

Note: The bearing must rest against the differential housing without clearance.

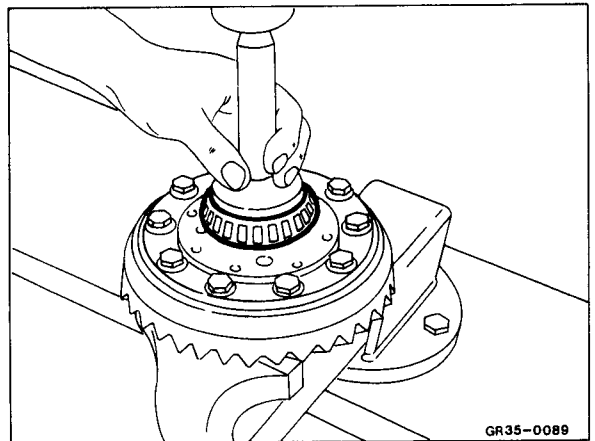

9 Bolt ring gear onto differential housing, tighten bolts to 170 to 190 Nm.

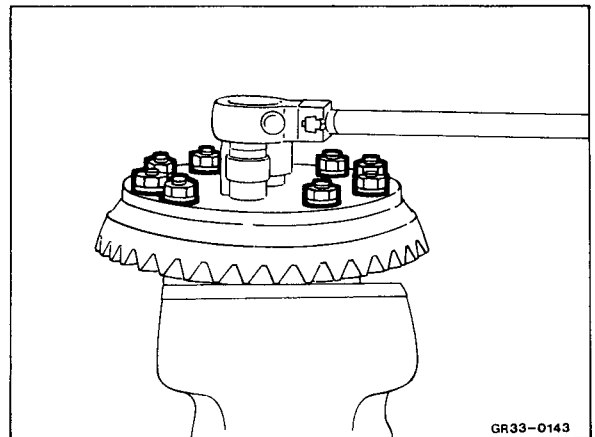

B. Without differential lock

Setting values

Friction torque for turning complete balance	Nm	50 to 80
----------------------------------------------	----	----------

Special tools 

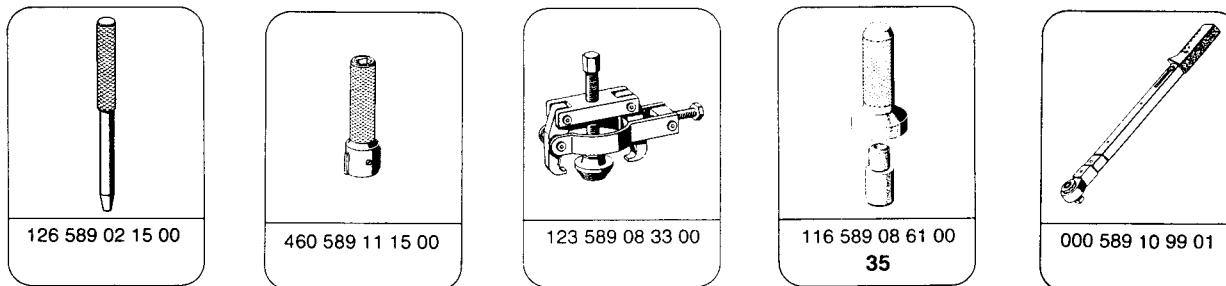

Differential – Tightening torques

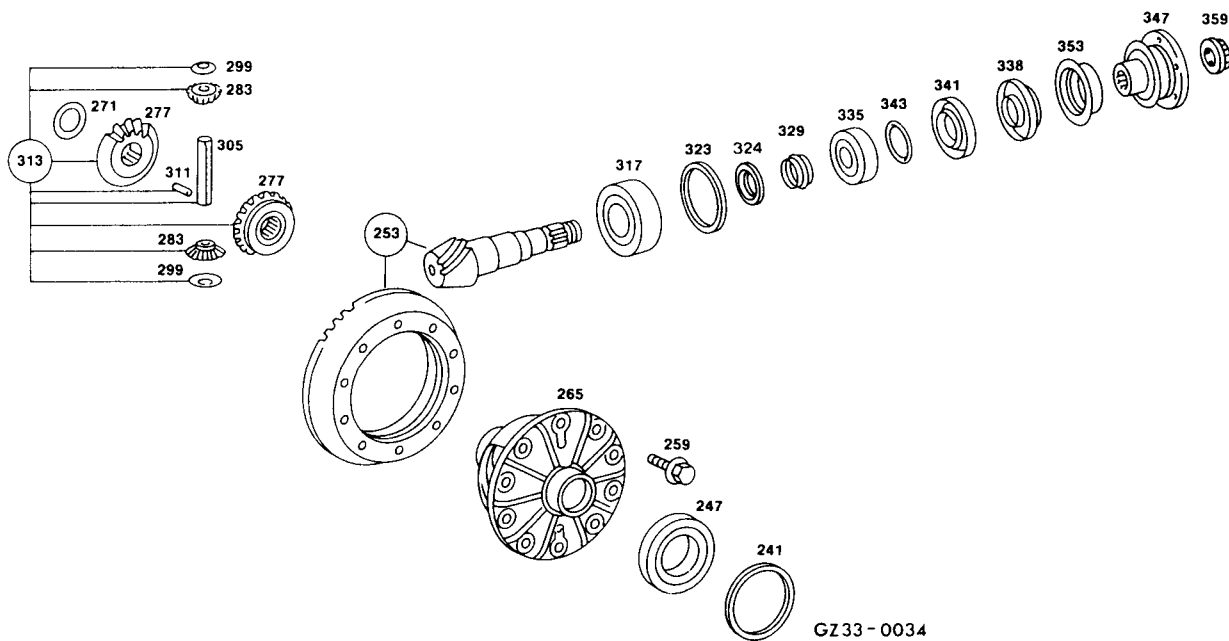
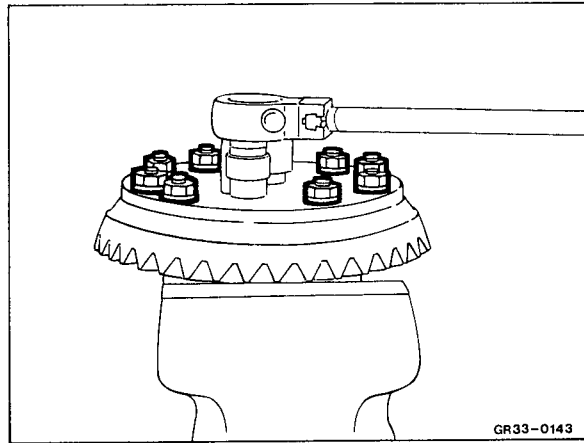



Fig. no.	Designation	Thread	Nm
259	Ring gear to differential housing	M 12 x 1 – 10.9	170 to 190

Disassembly

1 Unscrew and remove ring gear from differential housing.



2 Remove both tapered roller bearings.

 123 589 08 33 00

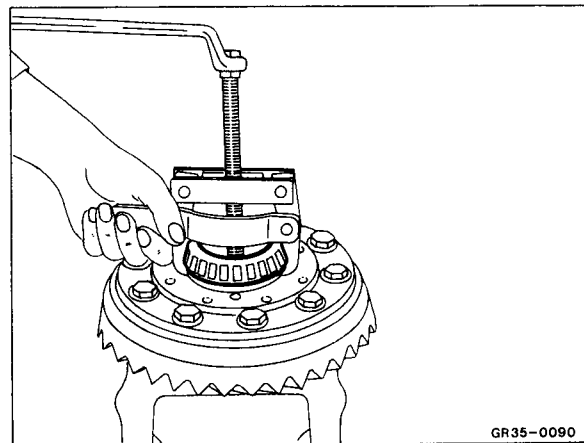

3 Knock out dowel pin, press out differential pinion shaft and remove parts.

Note: Mark relative positions of spherical washers, differential bevel gears as well as differential spider towards each other and towards the housing.

4 Clean all parts, check, exchange as required.

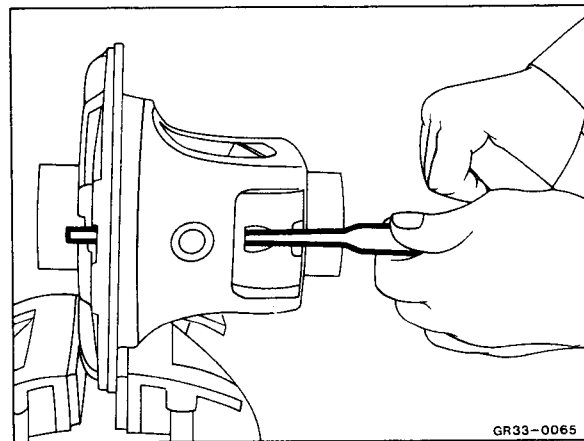

Assembly

1 Insert shim rings and side gears.

2 Centre side gears, install differential pinions with spherical washers.

 460 589 11 15 00

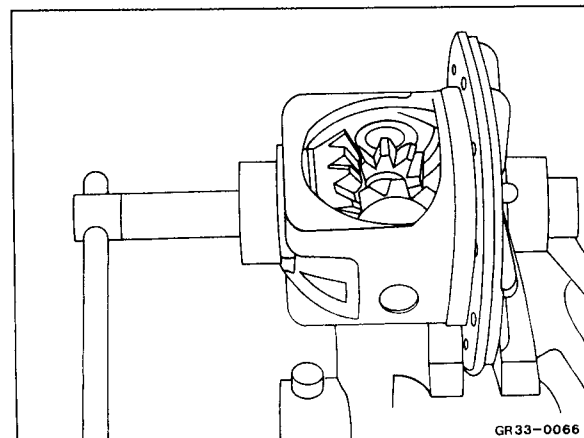

3 Fix both differential bevel gears.

 126 589 02 15 00

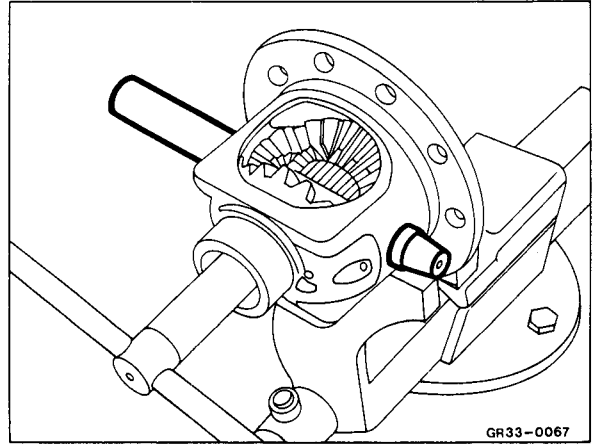

4 Check friction torque at both side gears using special tool.

permissible friction torque: 50 to 80 Nm.

Note: The friction torque can be adjusted by using thrustwashers with different thicknesses.

 460 589 11 15 00

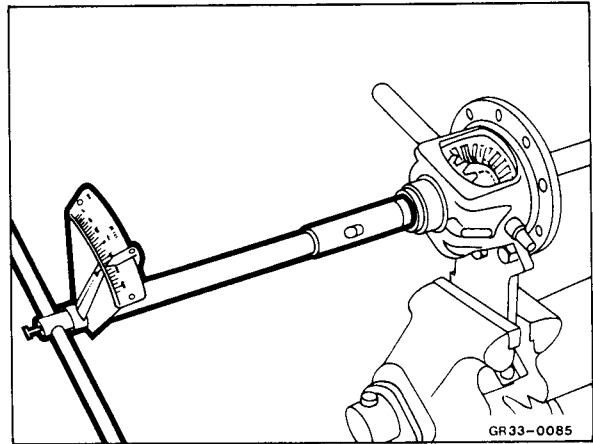

5 Drive in differential pinion shaft and secure with new dowel pin.

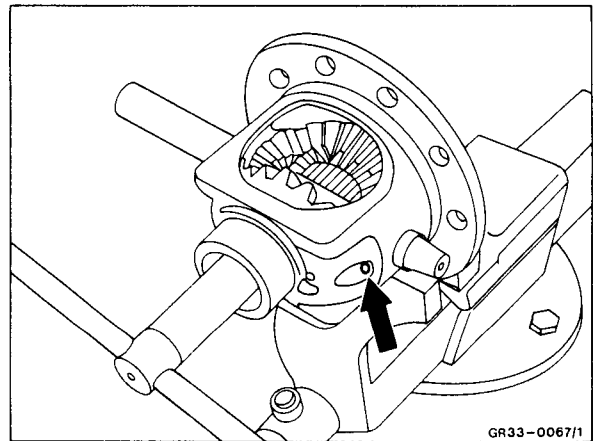

6 Heat both tapered roller bearings to approx. 80°C and fit.

 116 589 08 61 00

Note: The bearing must rest against the differential housing without clearance.

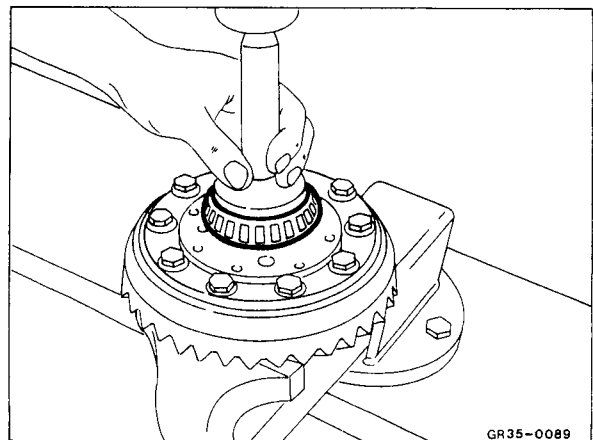

7 Bolt ring gear onto differential housing, tighten bolts to 170 to 190 Nm.

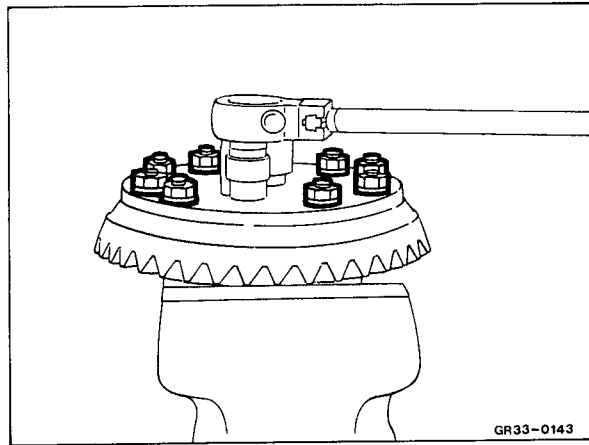

Setting values

Friction coefficient of the bevel gear with sealing rings	Nm	2,5 to 3,0
-----------------------------------------------------------	----	------------

Test value

Overall concentricity deviation of flange	mm	max. 0,07
-------------------------------------------	----	-----------

Special tools 

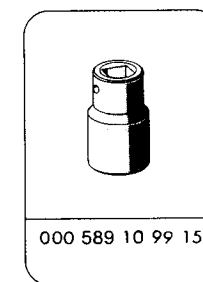
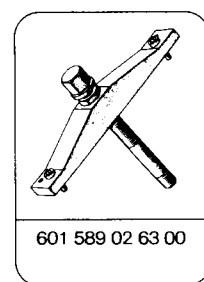
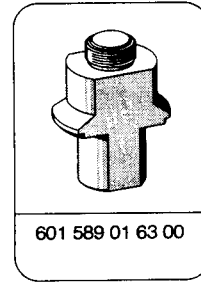
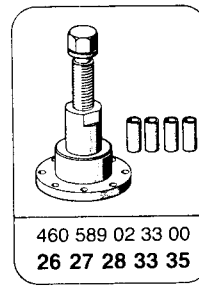
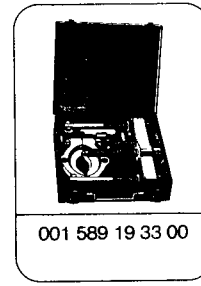
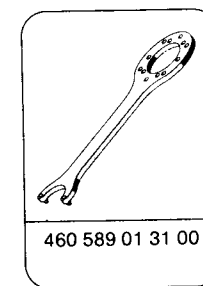
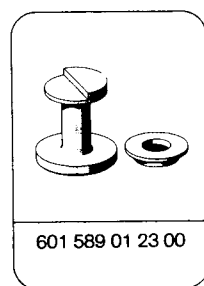
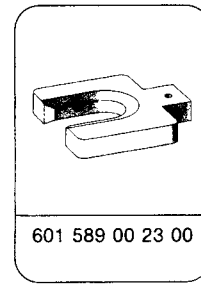
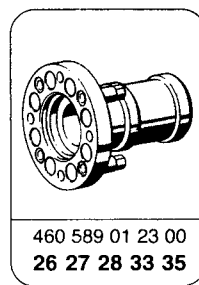
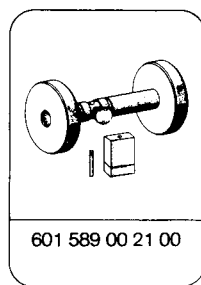
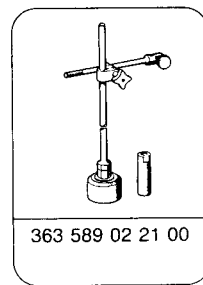
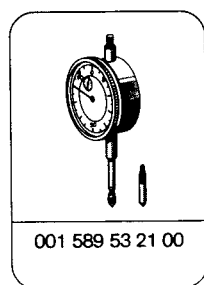
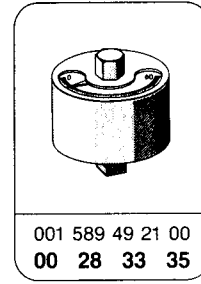
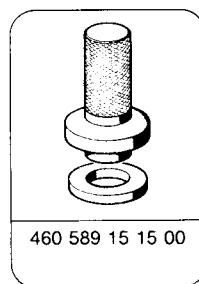
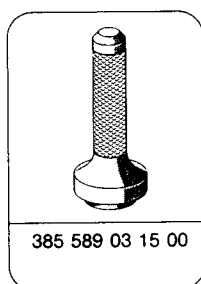
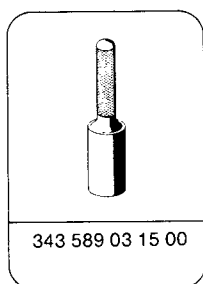
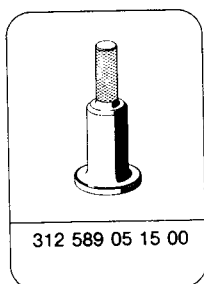

Expendable materials

Cons. No.	Designation	Part Number
2	Sealing compound: Omnifit FD 10	002 989 00 20 10
3	Lubricant: multipurpose grease	commercially

Bevel gear

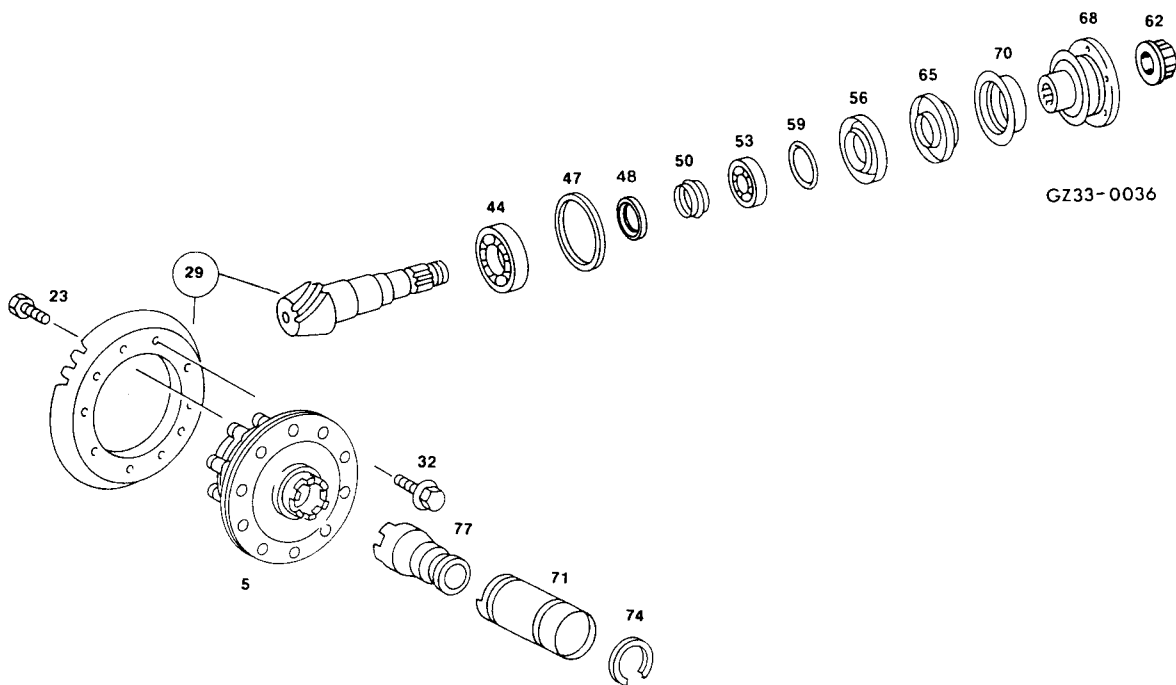

Removal and disassembly

1 Remove ring gear with differential, refer to 7.1/1.

2 Release nut and remove.

 000 589 10 99 15
460 589 01 31 00

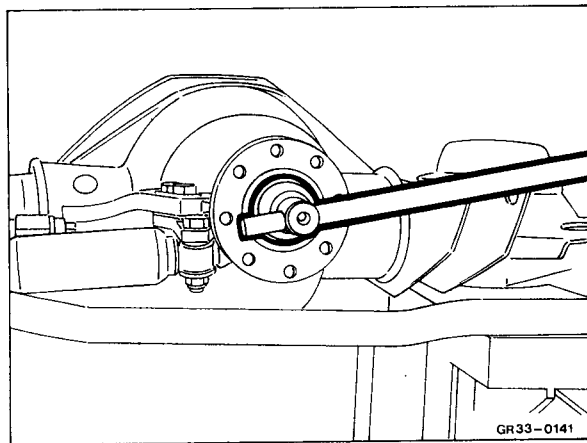

3 Remove flange.

 460 589 02 33 00

Note:

– On no account remove the flange by applying hard hammer blows, as this would damage the bearings.

– Mark the flange relative to the shaft.

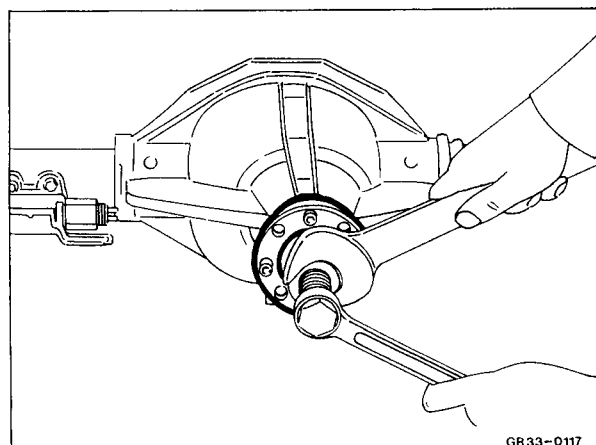

4 Bolt on special tool and remove bevel gear.

 601 589 02 63 00

Note: If necessary, drill out holes in the tool for taking up the bolts to approx. 11 to 12 mm dia. or remachine as elongated hole.

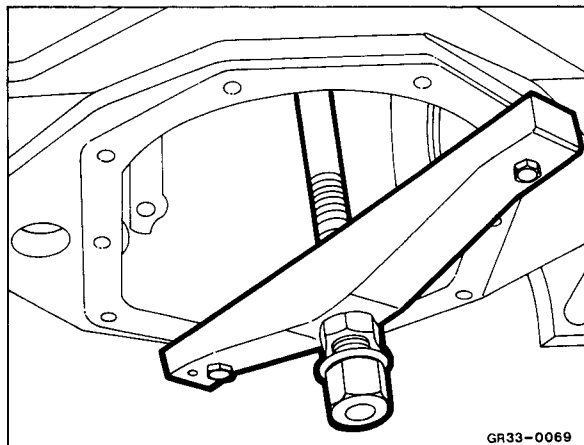

5 Remove tapered roller bearing and sealing ring.

 343 589 03 15 00

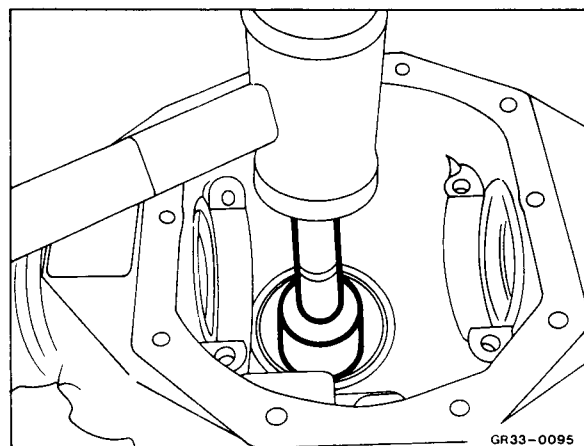

6 Remove outer bearing race, remove shim.

 601 589 01 63 00

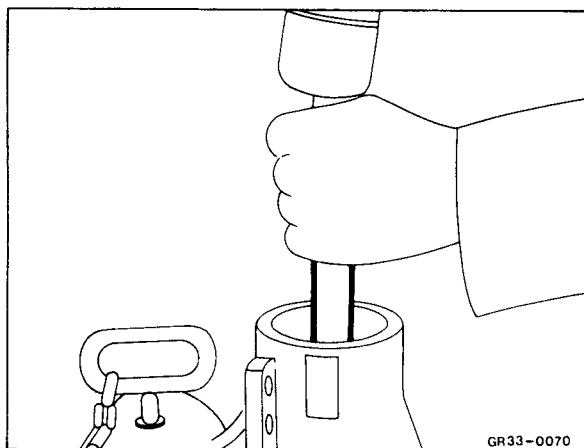

7 Pull tapered roller bearing.

 001 589 19 33 00

8 Clean all parts, check, exchange as required.

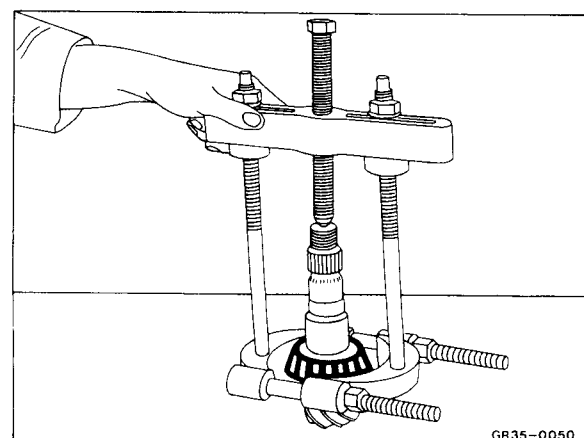

Assembly and installation

1 Drive on tapered roller bearing with suitable sleeve.

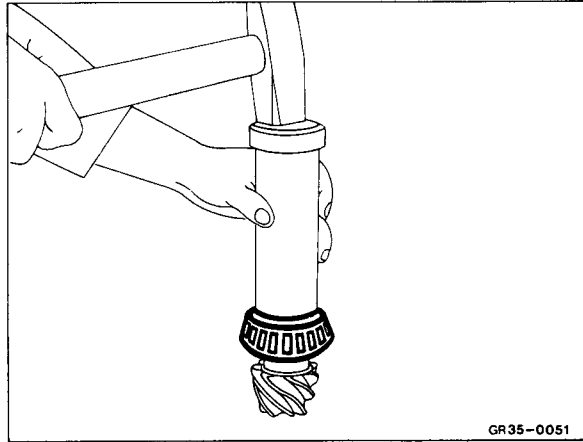

GR35-0051

2 Clamp in special tool. Set preload of 8 mm on dial gauge and set dial gauge to zero.

- Z** 001 589 53 21 00
- 363 589 02 21 00
- 601 589 00 23 00
- 601 589 01 23 00

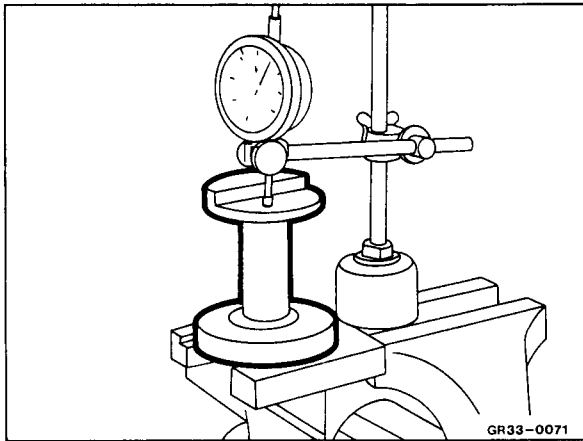

GR33-0071

3 Mount bevel gear with the tapered roller bearing and the magnetic plate (of the special tool) on measuring plate and turn several times, then note difference between bevel gear and special tool.

- Z** 001 589 53 21 00
- 363 589 02 21 00
- 601 589 00 23 00
- 601 589 01 23 00

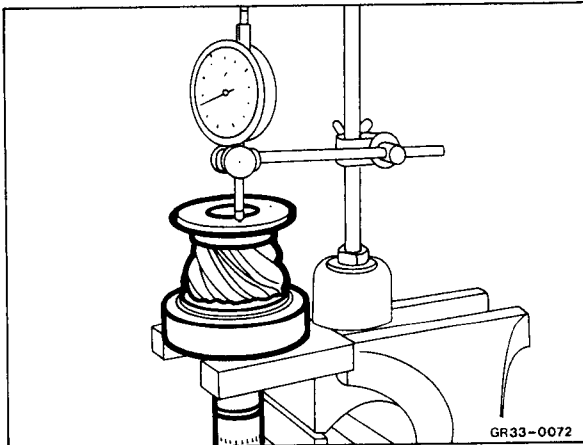

GR33-0072

4 Set special tool to **reference value of 66 mm**. Set preload of 2 mm on dial gauge and set dial gauge to zero.

- Z** 001 589 53 21 00
- 601 589 00 21 00

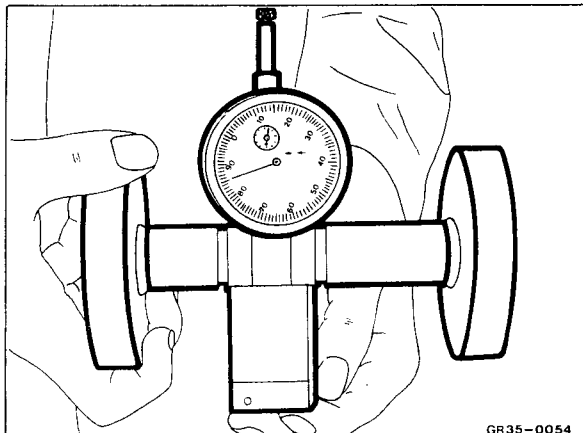

GR35-0054

5 Using special tools measure the difference between the production tolerance and the specified dimension.

B 601 589 00 21 00
601 589 01 23 00

Note: If the dial gauge reading is **greater** than 2 mm, **subtract** the difference from the value measured for item 3. If the dial gauge reading is **less** than 2 mm, **add** the difference.

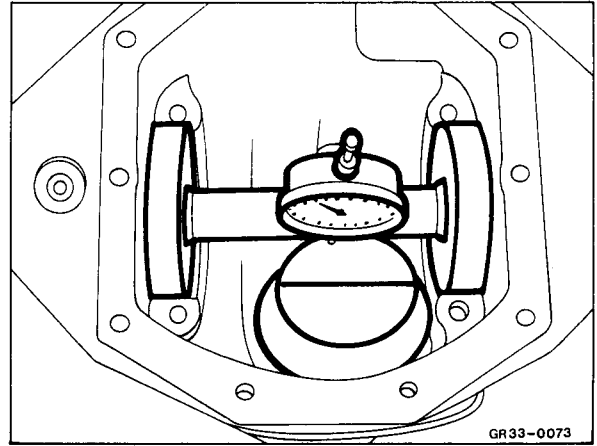

6 Read off basic dimension on bevel gear.

Note: If the dimension is **less** than 66 mm, **add** difference to the value measured for item 3. If the dimension is **greater** than 66 mm, **subtract** the difference.

The determined dimension corresponds to to the thickness of the shim.

- A Basic dimension to be adjusted
- B Center ring gear

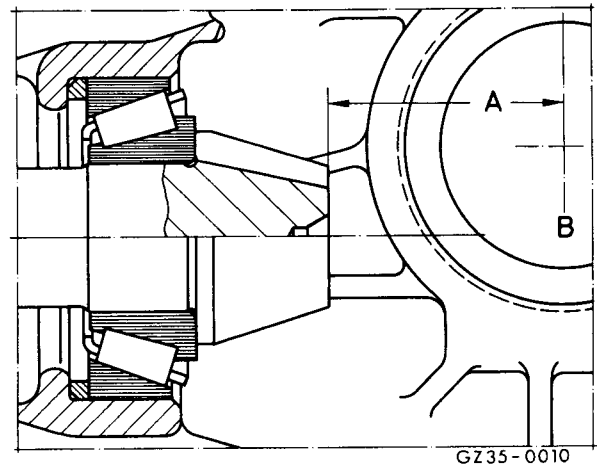

Shims are available in thicknesses of 5,0 to 5,68 mm in graduated stages of 0,02 mm.

Example: The difference from the measuring piece to the bevel gear is 5,30 mm. The production deviation is 0,12 mm greater. The written basic dimension is 65,84 mm
 $5,30 + 0,12 + 0,16 = 5,58$ mm
 Shim thickness of 5,58 mm.

- | | |
|---------------------------------------|----------------|
| 1 Shim | 5 O-ring |
| 2 Ring | 6 Sealing ring |
| 3 Oil retainer
(only in model 463) | 7 Sealing ring |
| 4 Compressed ring | 8 Nut |
| | 9 Flange |

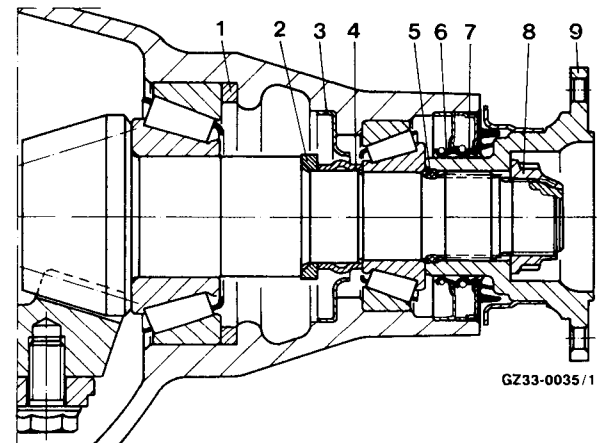

7 Insert determined shim in axle housing.

Note: The bevel must point toward the flange.

8 Install outer tapered ball bearing race.

B 312 589 05 15 00

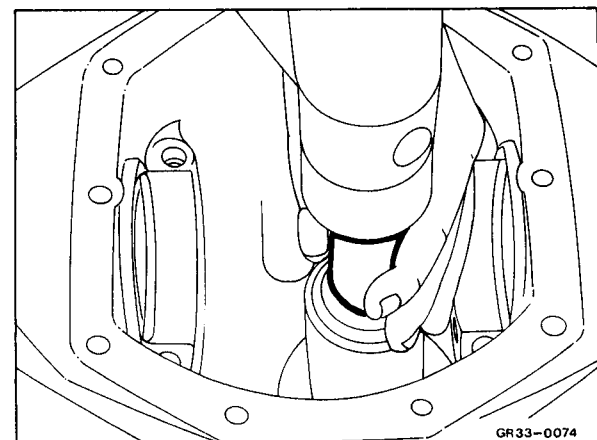

9 Install outer tapered ball bearing race.

 385 589 03 15 00

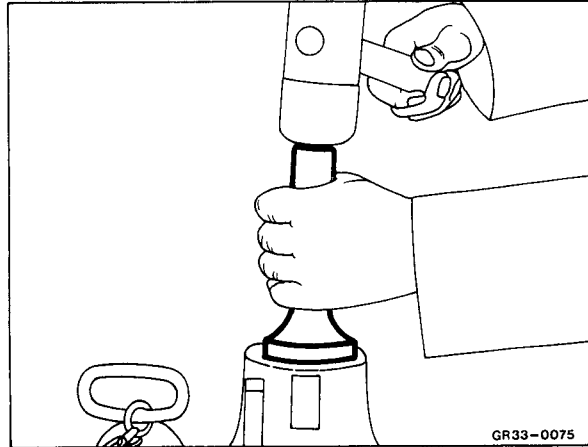

10 Insert bevel gear. Bolt on special tool and position spindle on bevel gear.

 601 589 02 63 00

Note: If necessary, drill out holes in the tool for taking up the bolts to approx. 11 to 12 mm dia. or remachine as elongated hole.

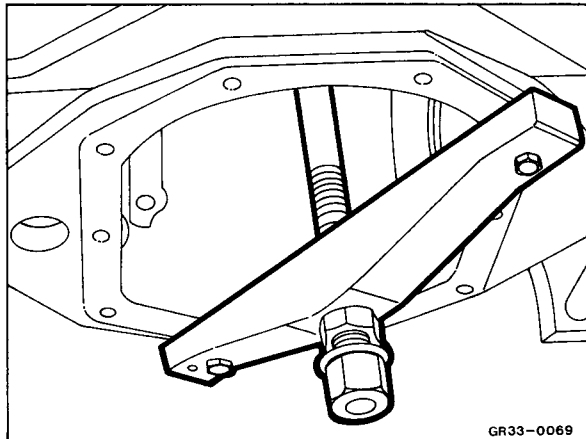

11 Insert **new** compressed ring and drive in tapered roller bearing with corresponding sleeve. Install new O-ring if installed.

Note: Since the compression ring was already compressed the first time it was installed, a new compression ring must always be used.

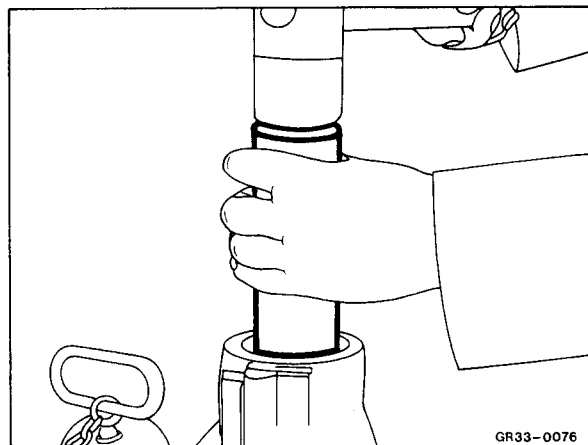

12 Install new sealing rings.

 460 589 15 15 00

Note: Note: Prior to installation of sealing rings, pack space between dust and sealing lips with lubricant no. 3, lightly grease the lips. Coat sealing rings at the outer periphery with sealing compound no. 2. (With exception of sealing rings with outer rubber coating).

Install inner sealing ring with washer and outer sealing ring without washer of special tool.

Note:

- Install sealing rings with outer rubber coating without sealing compound.
- Pay attention to any possible springing off of the garter springs. Grease garter springs.

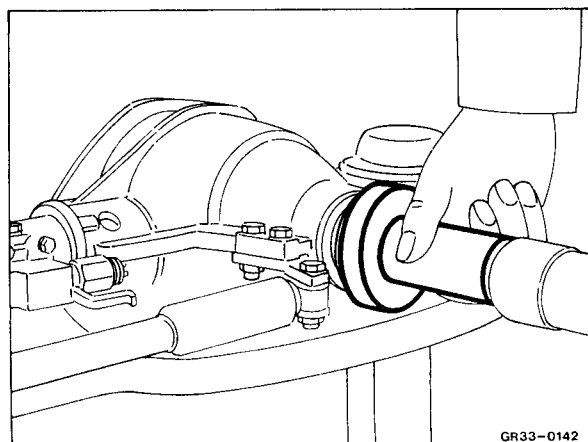

13 Install flange and screw in new nut.

Note: Pay attention to marking.

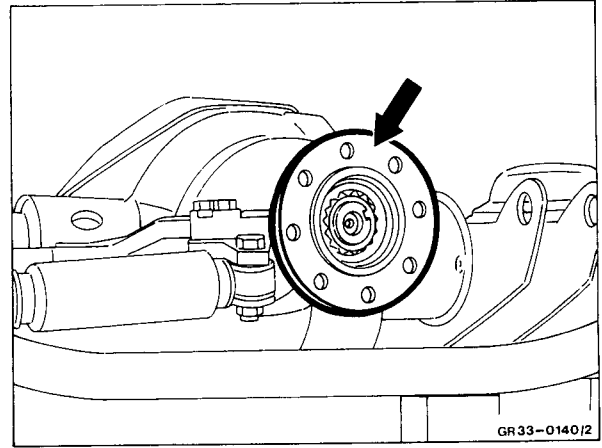

14 Attach special tool on flange. Tighten nut until a friction coefficient of 2,5 to 3,0 Nm is attained.

Permissible friction coefficient 2,5 to 3,0 Nm

B 000 589 10 99 15
460 589 01 31 00

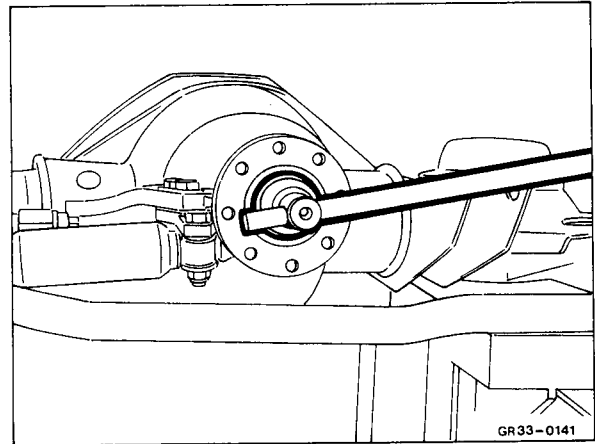

Note: Check friction coefficient using special tool. The friction coefficient should never be adjusted by loosening the nut. If the nut has been tightened too firmly, a new compression ring must be installed.

B 001 589 49 21 00

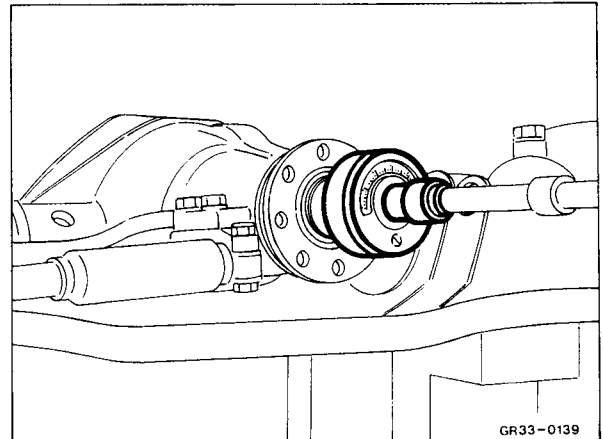

15 Secure nut.

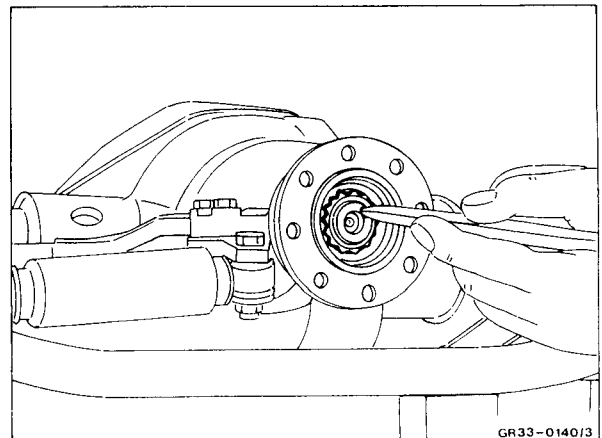

Note: Axially shear off lock collar of nut and bend in to base of groove so that the tab rests against the left flank of the locking groove.

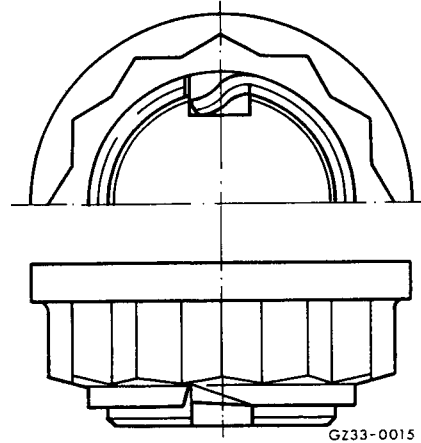

16 Check concentricity deviation on flange by means of special tool.

Total concentricity deviation < 0,07 mm

B 001 589 53 21 00
 363 589 02 21 00
 460 589 01 23 00

Note: Once the dimension of 0,07 mm is exceeded, detach the flange. Turn the flange and install again.

- 180° after first measuring procedure
- 90° after second measuring procedure
- 180° after third measuring procedure

This procedure is called „matching“ and is to be repeated max. 3 times. If the specified value is not attained using this method, replace the flange.

17 Install ring gear with differential, refer to 7.1/1.

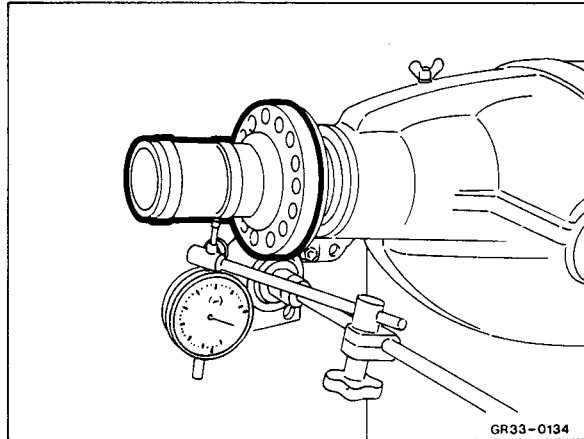

Sectional view

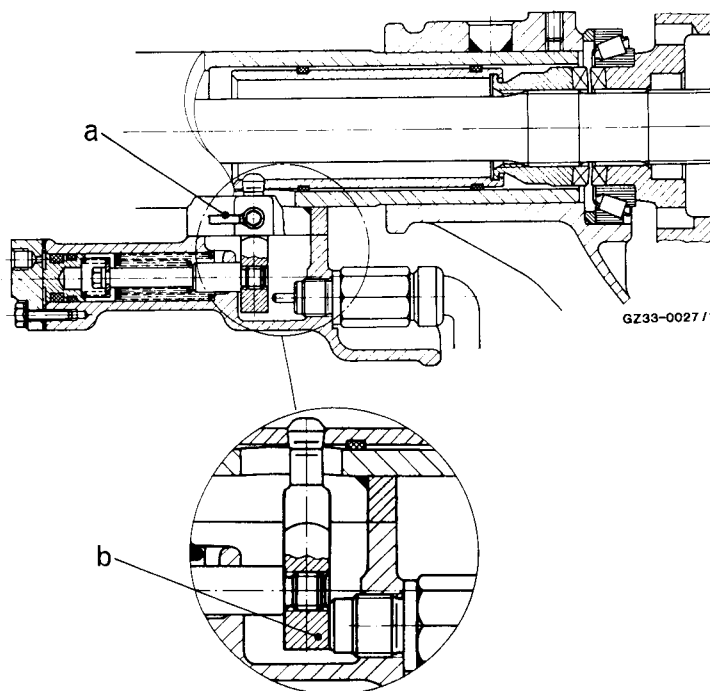

Shift cylinder

- a = Axle housing ventilation
- b = Shift finger

Expendable materials

Cons. No.	Designation	Part Number
3	Lubricant: multipurpose grease	commercially

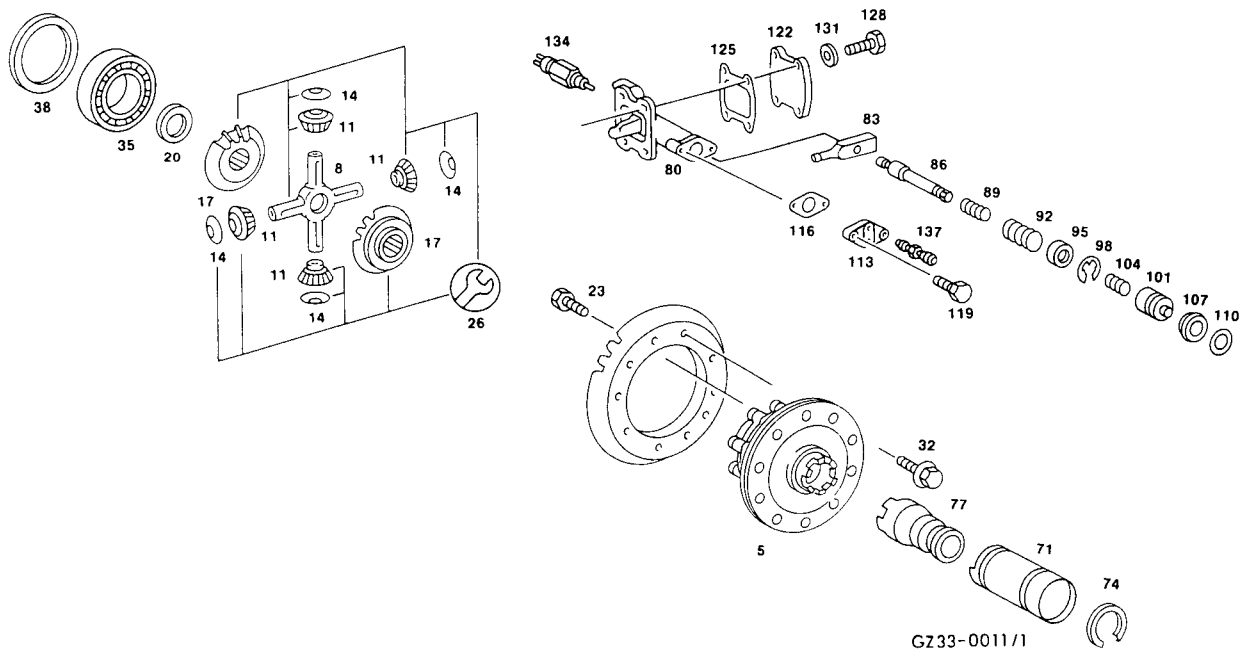

Removal

1 Mark shift cylinder in relation to axle tube.

Note: Only required when shift cylinder is not disassembled.

2 Remove shift cylinder.

3 Recondition shift cylinders, refer to 9.2/1.

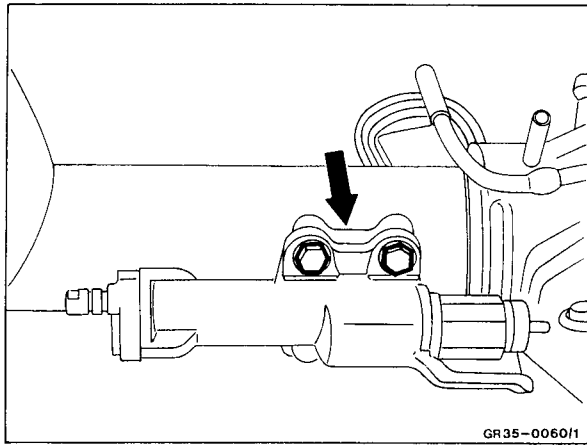

4 Remove joint housing and drive shaft, refer to 5.1/1.

5 Remove differential, refer to 7.1/1.

6 Pull out shift sleeve with shift tube slightly, detach shift sleeve, remove shift tube.

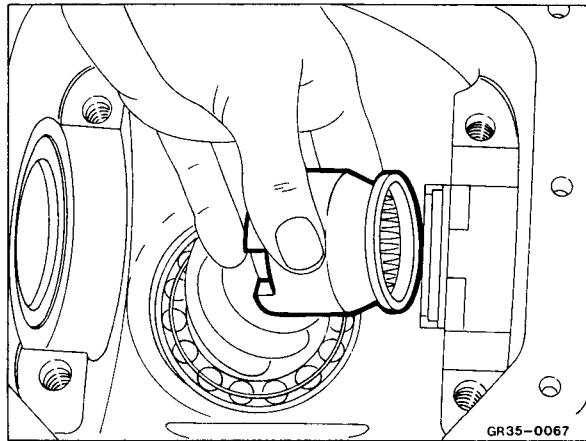

7 Remove polyamide rings on shift tube.

8 Clean all parts, check, exchange as required.

Installation

1 Install polyamide rings, coat outer running surface with lubricant no. 3.

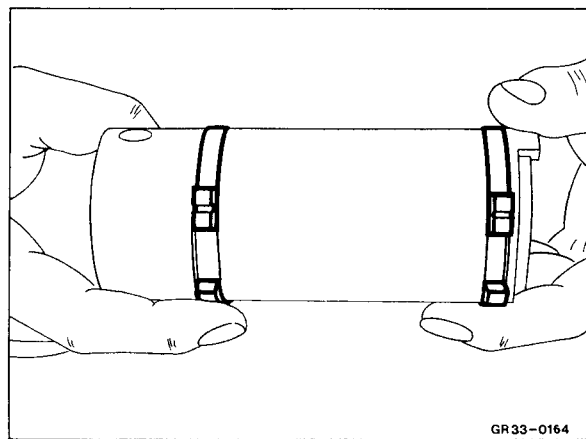

2 Insert shift tube.

3 Attach shift sleeve, push in shift tube until hole is visible at opening in axle housing.

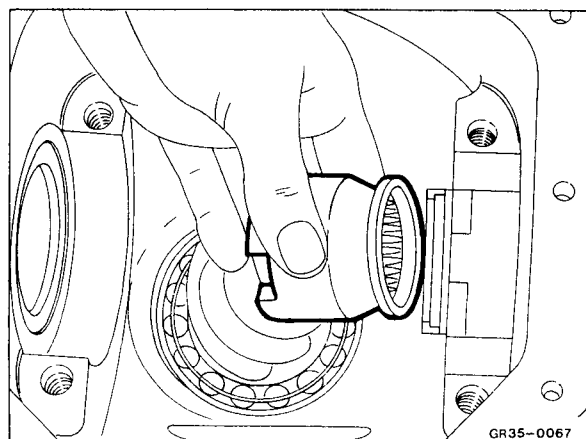

- 4 Install differential, refer to 7.1/1.
- 5 Install joint housing and drive shaft, refer to 5.1/1.
- 6 Attach shift cylinders after marking on the axle tube and tighten to 22 to 25 Nm.

Note: If the shift cylinder has been disassembled or renewed, or if switching components, differential housing or ring gear and pinion have been renewed, the shift cylinder must be re-adjusted, refer to 9.3/1.

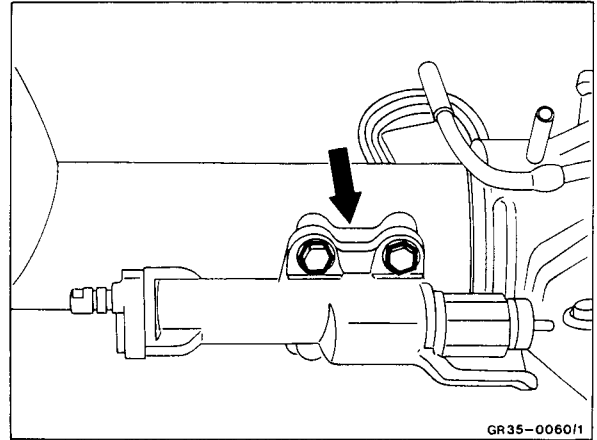

Special tools 

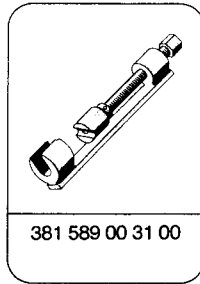
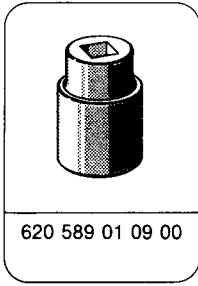

Expendable materials

Cons. No.	Designation	Part Number
4	Lubricant: Silicone-based grease	000 989 62 51
5	Locking agent: Loctite	002 989 94 71

Tightening torques

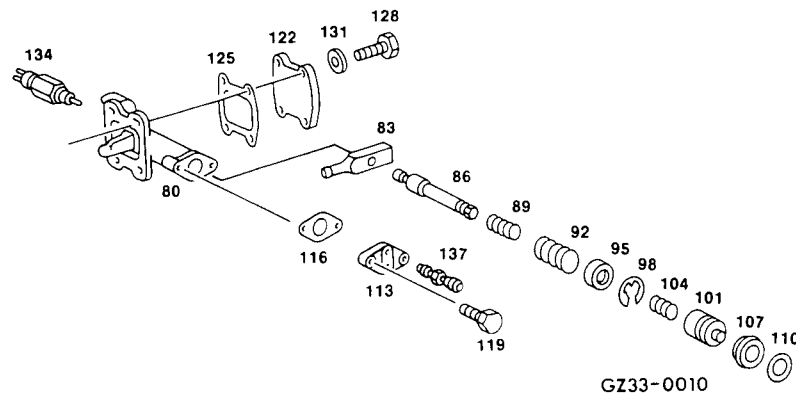

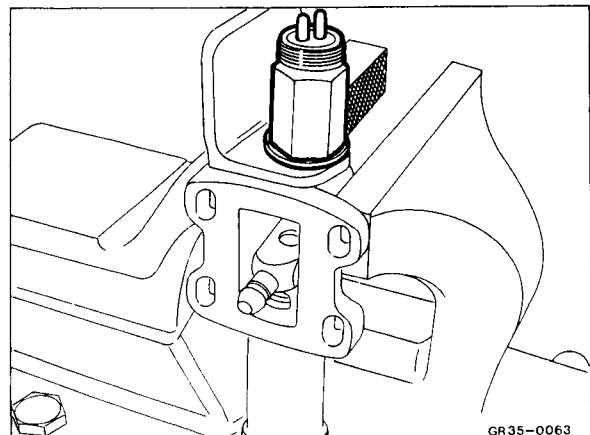

Fig. no.	Designation	Thread	Nm
83/86	Shift lever to shifter shaft	M 10 x 1,25	20 to 25
119	Cover on shift cylinder	M 6 – 10.9	16 to 20
128	Shift cylinder to axle tube	M 8 – 8.8	22 to 25
134	Pressure switch to shift cylinder	Initial torque	M 18 x 1,5 10 to 20
		Final torque	M 18 x 1,5 95 to 105

Disassembly

- 1 Remove shift cylinder.
- 2 Remove pressure switch.

 620 589 01 09 00



3 Unscrew cover from shift cylinder.

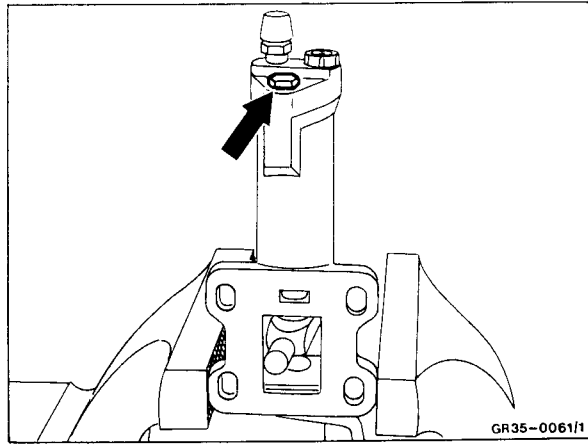

4 Remove spring and control piston.

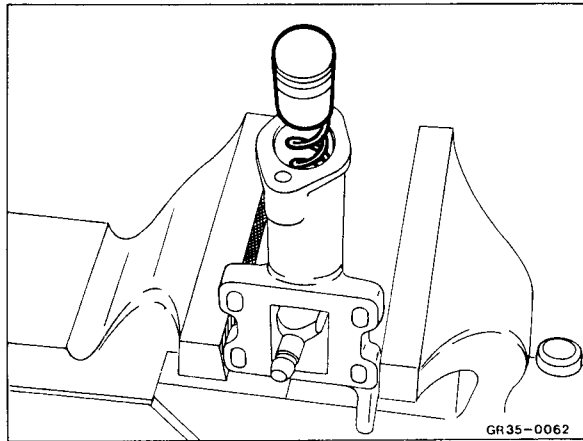

5 Unscrew shaft from lever.

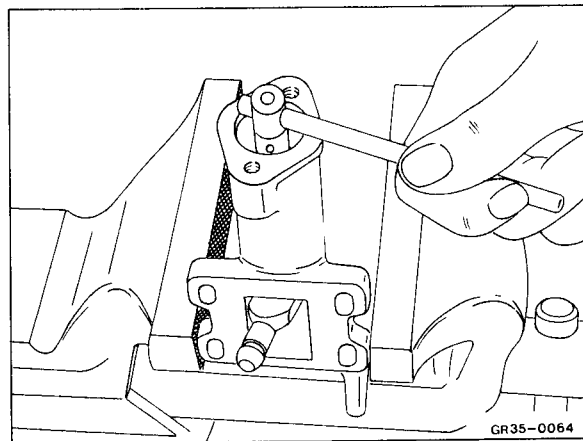

6 Remove shaft with pressure springs.

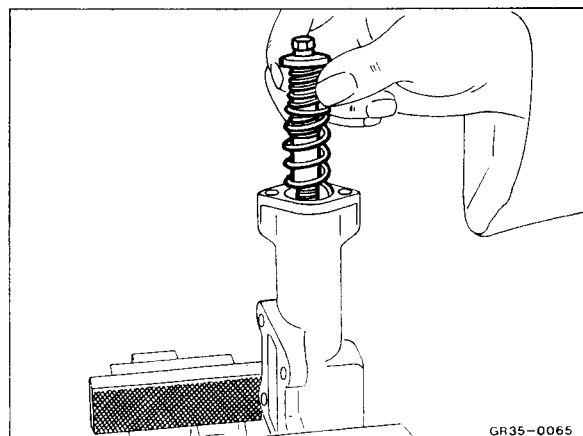

8 Remove spring.

 381 589 00 31 00

9 Clean all parts, check, exchange as required.

Assembly

1 Install spring.

 381 589 00 31 00

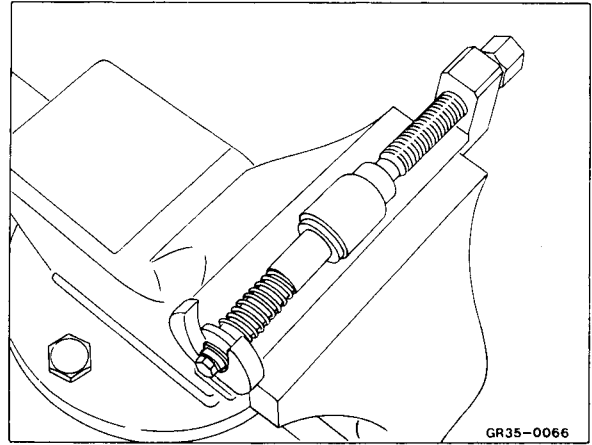

Note: Coat all sliding parts with lubricant no. 4.

2 Coat shaft on thread with locking agent no. 5 and insert with pressure spring in shift cylinder.

3 Bolt shaft onto lever bolt, tighten to 20 to 25 Nm.

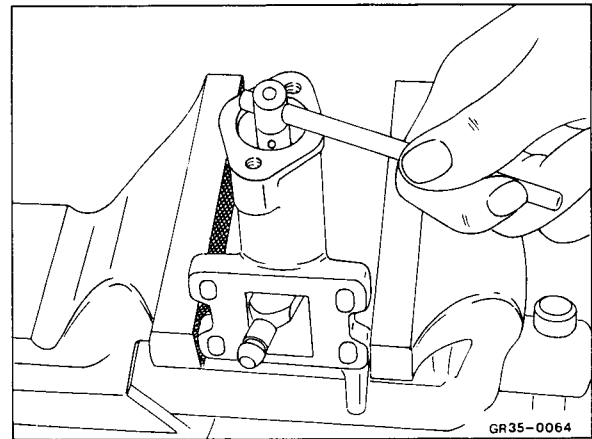

4 Install new sealing ring and new gaiter.

- 1 Gaiter
- 2 Sealing ring

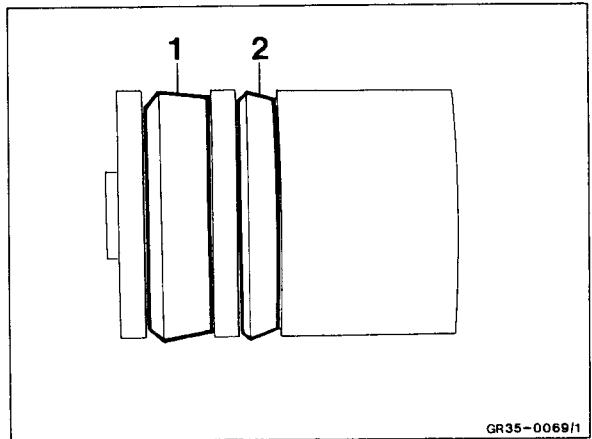

5 Insert control piston and spring.

6 Bolt on covers and tighten to 16 to 20 Nm.

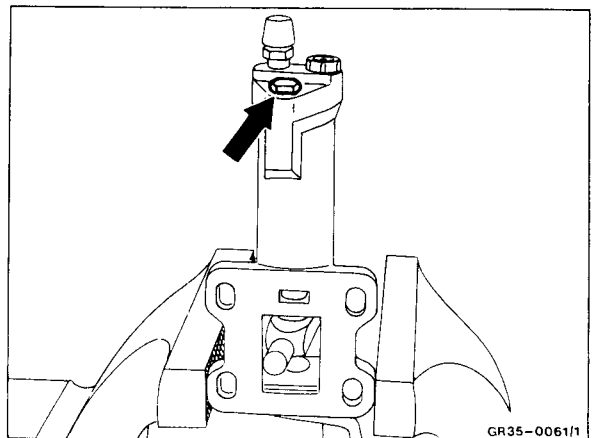

7 Screw in pressure switches, tighten to 10 to 20 Nm.

 620 589 01 09 00

Note: Do not tighten to final torque of 95 to 105 Nm until the shift cylinder has been installed.

8 Adjust shift cylinder, refer to 9.3/1.

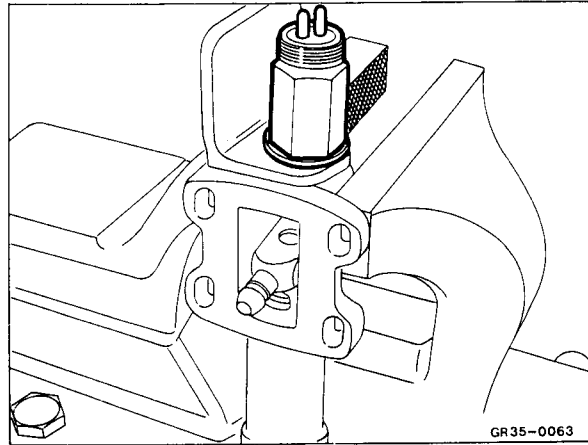

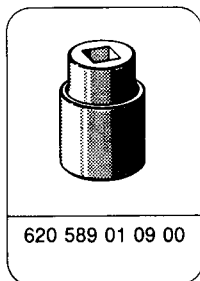
Special tools 

Tightening torques

Designation		Thread	Nm
Pressure switch to shift cylinder	Initial torque	M 18 x 1,5	10 to 20
	Final torque	M 18 x 1,5	95 to 105

Adjustment

1 Screw in pressure switches, tighten to 10 to 20 Nm.

 620 589 01 09 00

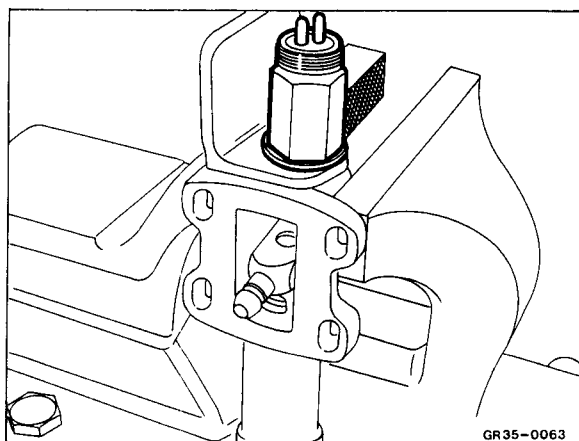

2 Secure shift cylinder to axle bridge housing in such a way that it can still be shifted.

3 Actuate shift cylinders and engage dog coupling.

4 Shift shift cylinder up to stop of dog coupling, which can be clearly felt, wherein however the inner spring must not be tensioned (i.e. upon release, the shift cylinder must not move back).

5 Tighten shift cylinders, tighten bolts to 22 to 25 Nm.

6 Tighten pressure switch to 95 to 105 Nm.

 620 589 01 09 00

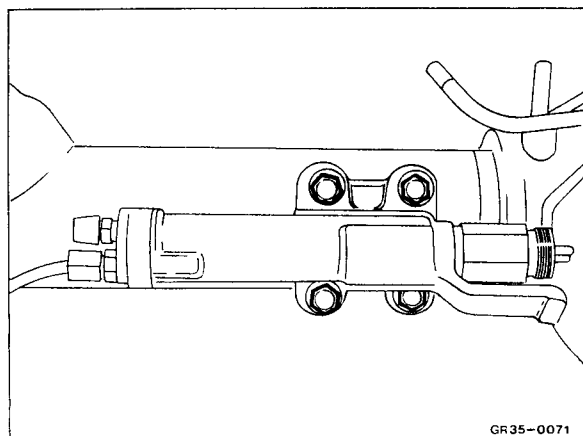

Test values

Overall concentricity deviation at flange	mm	< 0,07
-------------------------------------------	----	--------

Tightening torques

Designation	Nm
Flange to propeller shaft	35

Special tools 

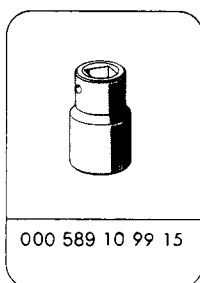
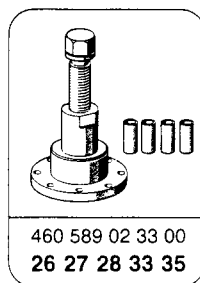
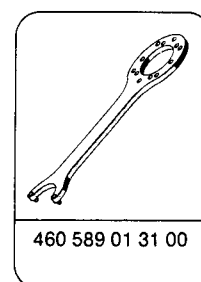
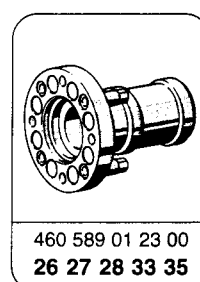
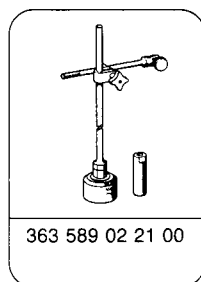
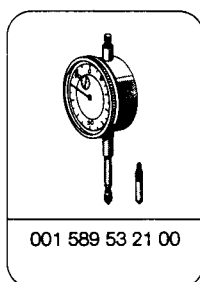
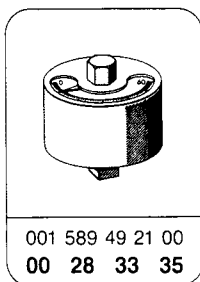

Tool for self-assembly

Base plate for measuring stand

Material: St 37

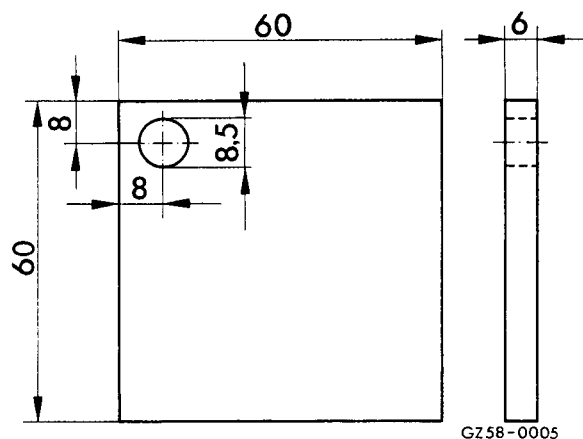

Expendable materials

Designation	Part Number
Sealing compound: Omnifit FD 10	002 989 00 20 10
Lubricant: multipurpose grease	commercially

Test

Note: Carry out this test in the event of complaints caused by wobbling at the flanges.

1 Detach propeller shaft and attach orifice flange.

 460 589 01 23 00

2 Attach dial gauge and bracket to the transmission housing.

 001 589 53 21 00
363 589 02 21 00

Note: The base plate (self-assembly) can be used as an attachment possibility.

3 Check the overall concentricity deviation < 0,07 mm at the front measuring surface.

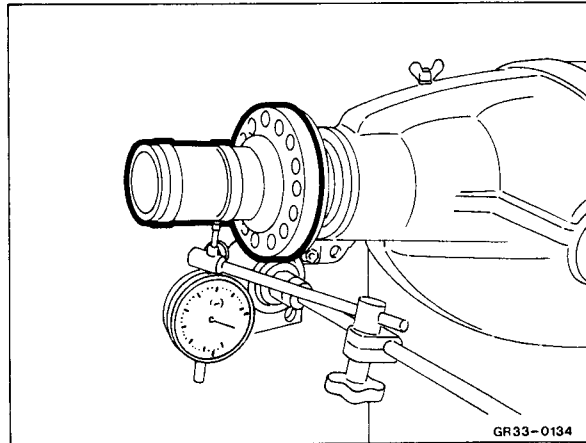

4 If the **dimension is not** attained, detach the flange with the retaining wrench and puller.

 460 589 01 31 00
460 589 02 33 00

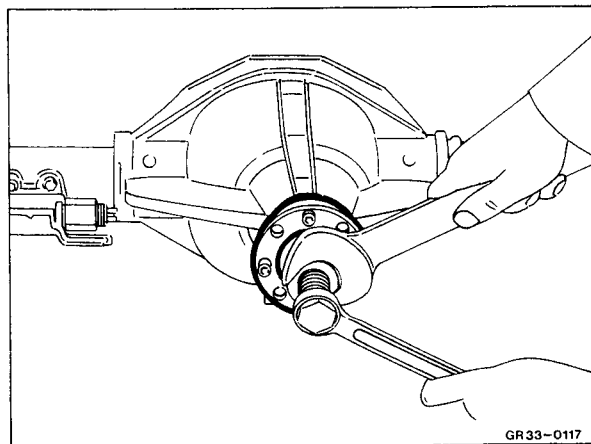

Removal

5 Measure friction torque of entire axle (without wheels) the flange with special tools each time before the flange and sealing rings are disassembled. Note measured friction torque.

 000 589 10 99 15
001 589 49 21 00

Note: Make sure that the brake is released.

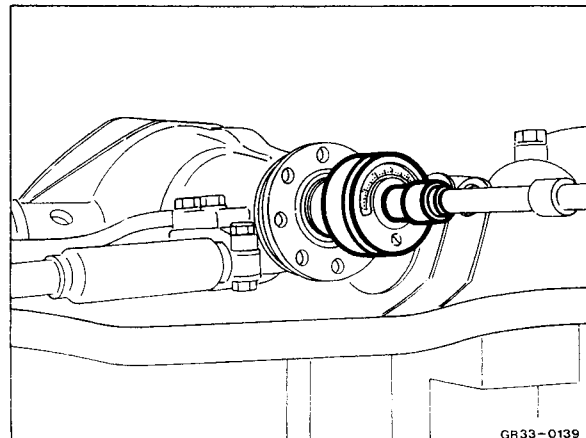

6 Mark flange relative to bevel gear (due to wobble).

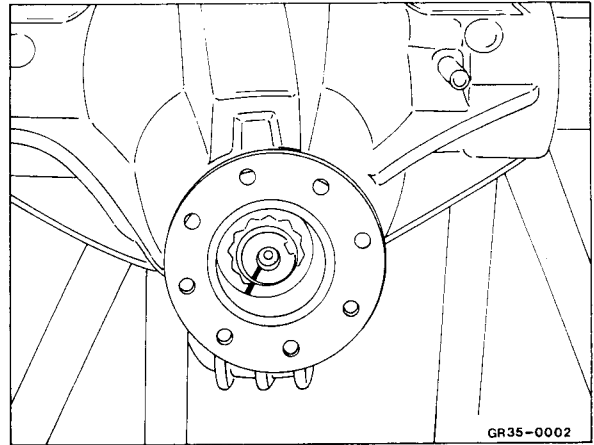

Note: Release nut.

7 Remove nut.

 000 589 10 99 15
460 589 01 31 00

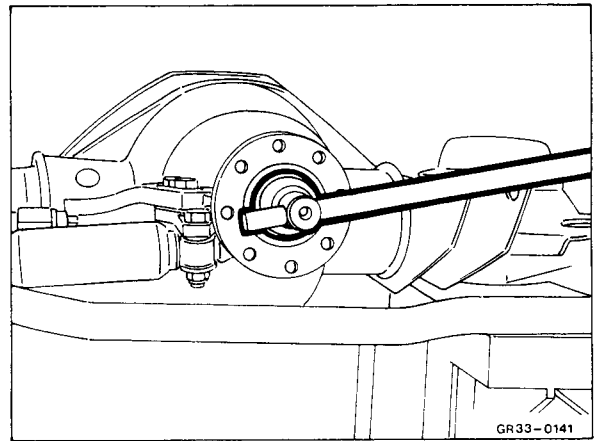

8 Remove flange.

 460 589 02 33 00

Note: Do not remove flange with hard hammer blows under any circumstances. This would damage the bearings.

9 Check flange for damage and scoring.

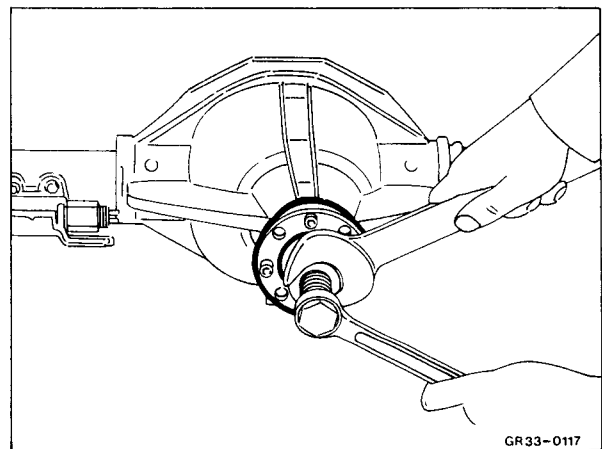

10 Install flange.

Note: Pay attention to marking.

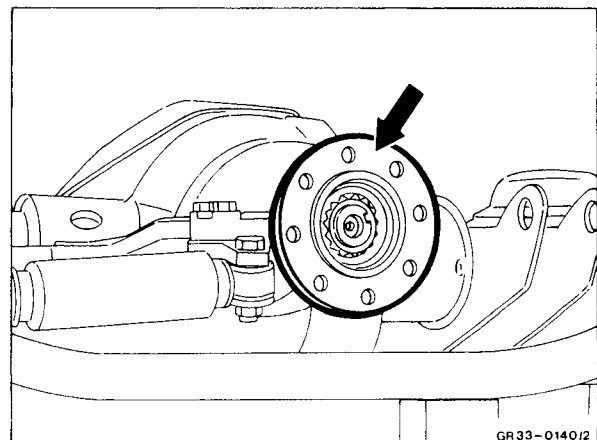

11 Install new nut.

12 Measure friction torque.

 000 589 10 99 15
001 589 49 21 00

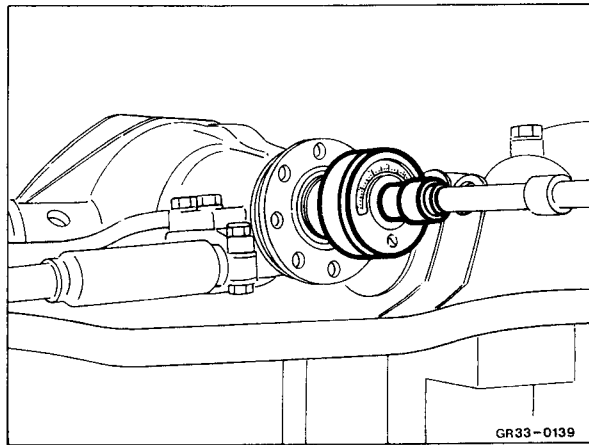

13 Install new nut. Alternately tighten nut and measure friction torque until the friction torque measured in point 12 is reached. The friction torque to be adjusted should exceed the value measured in point 12 by **0,5 Nm**.

 000 589 10 99 15
460 589 01 31 00

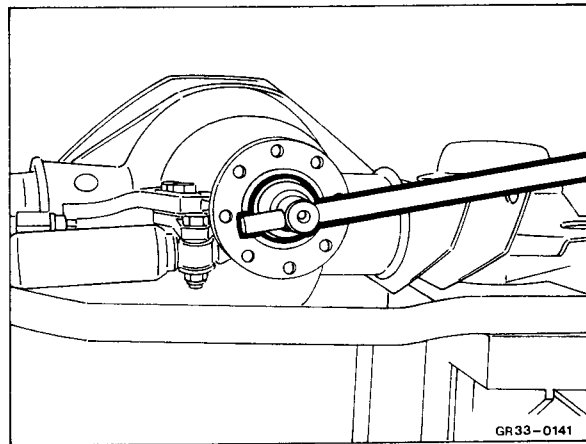

Note: If the nut is tightened excessively, the compressed ring is compressed too much. For this reason the bevel gear must be removed, the compressed ring replaced and the bevel gear adjusted again.

- | | |
|---------------------------------------|-----------------------|
| 1 Shim | 5 O-ring |
| 2 Ring | 6 Radial sealing ring |
| 3 Oil retainer
(only in model 463) | 7 Radial sealing ring |
| 4 Compressed ring | 8 Nut |
| | 9 Flange |

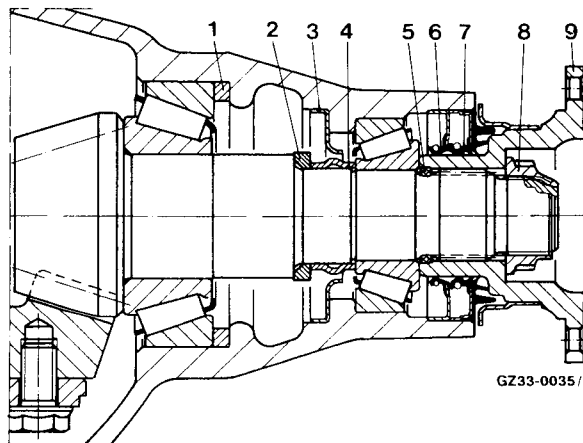

14 Check concentricity deviation on flange by means of special tool.

Total concentricity deviation < 0,07 mm

 001 589 53 21 00
363 589 02 21 00
460 589 01 23 00

Note: Once the dimension of 0,07 mm is exceeded, detach the flange. Turn the flange and install again.

180° after first measuring procedure

90° after second measuring procedure

180° after third measuring procedure

This procedure is called „matching“ and is to be repeated max. 3 times. If the specified value is not attained using this method, replace the flange.

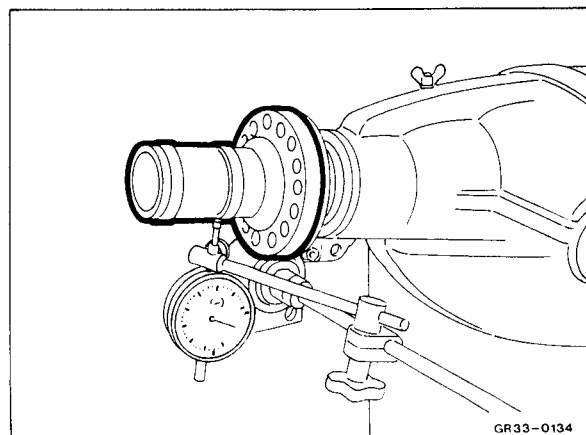

15 Secure nut.

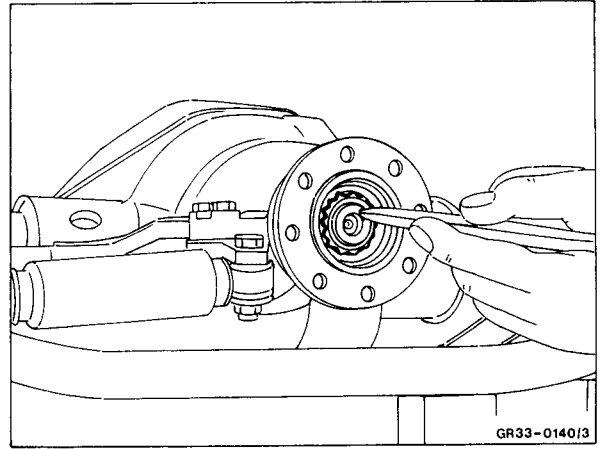

Note: Axially shear off lock collar of nut and bend in to base of groove so that the tab rests against the left flank of the locking groove.

