

# Dealer Ordering Guide



## Mercedes-Benz MY16 GLC-Class (X253)

## **An important note about this Guide:**

The information presented in this guide is based on the most current information available and is intended for internal use only. Mercedes-Benz reserves the right to make changes at any time, without notice, to colors, materials, equipment, special specifications and models. Pricing may not yet be finalized for some models or options.

Due to variances among monitors and printers the colors that appear on your screen and printouts may not be exact.

For illustrative purposes, some images may show vehicles with European Specification.

## Revision History

Date	Changes
6/23/2015	Initial Release
7/2/2015	Added Notation to Panorama Roof Stand-alone Option
7/23/2015	Modified Packages
7/24/2015	Modified SPC Options

## Table of Contents

- [What's new in MY16](#)
- [Models](#)
- [Standard Equipment](#)
- [Paints](#)
- [Upholsteries](#)
- [Trims](#)
- [Wheels](#)
- [Visual Equipment Differentiation](#)
  - [Headlights](#)
- [Option Packages](#)
- [Stand-Alone Options/Special Orders/Accessories](#)
- [Specifications](#)
- [Product Highlights](#)
- [Advantages over competition](#)
- [Gallery](#)

## What's new: MY16 Overview

### Exterior

- All-new exterior design

### Interior

- All-new interior design

### Standard Equipment

- Collision Prev. Assist PLUS (CPA+)
- PRE-SAFE
- Crosswind Assist
- KEYLESS-START
- Touchpad
- Power Driver Seat with Memory
- Rearview Camera
- Power Tailgate
- Power Folding Mirrors
- 7" Color Display
- Media Interface (iPod etc.)
- 9 Speed Transmission
- DYNAMIC SELECT
- 2.0L turbo-4 (241 hp, 273 lb-ft)



## What's new: MY16 Overview

### Optional Equipment

- New Premium Package Structure
- New Night Package (521 Pkg)
- DISTRONIC PLUS with Steering Assist
- PRE-SAFE PLUS with Rear-End Collision Prevention
- BAS PLUS w/ Cross-Traffic Assist
- Ventilated Front Seats
- Illuminated Door Sills
- MB-Tex Covered Dashboard
- Heated Rear Seats
- Air Balance
- Ambient Lighting
- Head-Up Display
- NTG 5 with 8.4" COMAND Screen
- Multi-Chamber Air Suspension

### Paints

- Addition of metallic paints: Selenite Grey and Cardinal Red
- Addition of *designo* MAGNO Dakota Brown

### Upholsteries

- New color options
- New *designo* upholstery

### Trims

- Addition of Linden Wood Trim (H07)
- Addition of Black Ash Open-Pore Wood Trim (736)

### Wheels

- New 18", 19" and 20" wheel designs



## What's new: Premium Package Structure

With added components moving to standard equipment the Premium Package is now delighting customers with expanded content at a lower price.

### MY15

#### Premium 1 Package

- Garage door opener
- Compass
- Auto-dimming mirrors
- Panorama roof
- Media interface with cable
- SiriusXM Radio
- Power liftgate
- 115V Power Outlet

▪ **MSRP \$3,450**

### MY16

#### Now Standard Equipment

- Garage door opener
- Media interface
- Power liftgate

#### Premium Package

- Blind Spot Assist
- SiriusXM Radio
- KEYLESS GO
- Heated Front Seats
- 115V Power Outlet

▪ **MSRP \$1,850**



## What's new: 321 – Sport Package

\$2,950

*Optional on all models*



Added sportiness, exclusivity and fun at the wheel are all part of the perfectly coordinated package of equipment that makes up the AMG Line Exterior.

The Sport Package includes:

- ① AMG body styling consisting of AMG front and rear apron
- ② 19" AMG Himalaya Grey 5-twin-spoke light-alloy wheels (638)
  - MB-Tex Covered Dashboard & Upper Door Panels w/Top-Stitching





## What's new: 521 – Night Package

**\$300**

*Only in conjunction with 321 Sport Package*



Striking design features in black underscore the sporty, expressive character of the vehicle

The Night Package includes:

- ① Radiator trim with integral Mercedes star and two lamellas in high-gloss black with chrome inserts
- ② 19" AMG 5-twin-spoke light-alloy wheels painted in high-gloss black with a high-sheen finish (99R)
  - Optional: 20" AMG multi-spoke light-alloy wheels painted in high-gloss black with high-sheen finish (698)
- ③ Roof rails powder-coated in matte black
- ④ Under guard front/rear painted in black
- ⑤ Exterior mirrors painted in high-gloss black
- ⑥ Waistline trim strip and window weather strip in high-gloss black



## What's new: DYNAMIC SELECT

*Standard on all GLC*



At a touch of the DYNAMIC SELECT feature, drivers can choose between comfortable, sporty, particularly sporty and efficient driving styles, or their own individually defined style. Parameters such as the engine, transmission and steering characteristics are adjusted according to the selected drive mode.

Choice of up to 5 different driving programs:

1. "Comfort" standard setting: well-balanced and fuel-efficient
2. "Eco" mode: for keeping fuel consumption as low as possible
3. "Sport" mode: added agility and dynamism thanks to a more direct steering characteristic curve, sporty, taut suspension tuning (in conjunction with AIRMATIC), spontaneous throttle response and modified shift points (with 9G-TRONIC PLUS)
4. "Sport+" mode: even sportier performance, the suspension (in conjunction with AIRMATIC) and drive system have an even more dynamic setup
5. "Individual" mode: individual parameters can be varied as required, using the Controller and the configuration menu in the head unit



## What's new: 421 – 9G-Tronic

*Standard on all GLC*

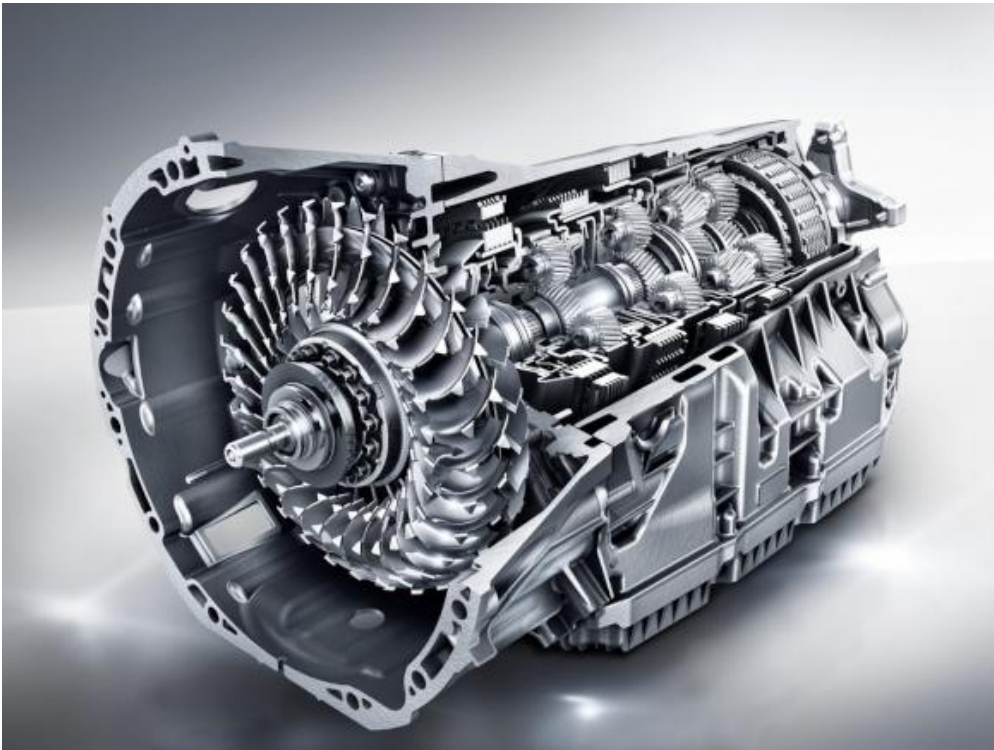

9G-TRONIC – faster, smoother, more efficient

Featuring nine forward gears, this automatic transmission takes efficiency, comfort and dynamism to a completely new level. It is the world's first 9-speed automatic transmission with hydrodynamic torque converter in the premium segment. The larger ratio range allows a reduction in engine speed. Performance remains excellent while ride comfort is enhanced and noise levels are reduced. The reduced intervals between the gears lead to faster gear changes and enhanced spontaneity and agility. At the same time, the 9G-TRONIC impresses with smooth, barely perceptible gear shifting like that of a continuously variable transmission. As the 9G-TRONIC is able to skip individual gears, multiple downshifts are possible for fast and powerful sprints.

## What's new: 448 – Touchpad

*Standard on all GLC*



The functions of COMAND Online and Audio 20 CD can be controlled intuitively via the innovative touchpad, using single or multiple-finger gestures (multi touch).

- Touchpad approx. 2.56 x 1.77 inches in size and comfortable hand rest in one single component
- Additional full-fledged input option for COMAND Online and Audio 20 CD in addition to the COMAND Controller and LINGUATRONIC
- Recognizes single and multiple-finger gestures (multi touch), swiping movements and zoom gestures achieved by spreading the fingers or pinching them together
- Innovative handwriting recognition feature: Users are able to input letters, special characters and numbers in their normal handwriting, in any language available in the head unit
- 3 buttons located behind the touchpad allow fast and direct operation of important functions
- Clear haptic feedback when using the touchpad or keys



## What's new: 463 – Head-up display

\$990

*Optional on all GLC*



The Head-up Display at a glance:

- Key driver information at a glance, without the driver having to take their eyes off the road
- Projection of a virtual image measuring approx. 8.3 x 2.8 inches into the driver's field of vision, which appears to float around 78.7 inches in front of him/her above the bonnet
- Presentation of information in high-resolution and in color, making it clearly legible even on sunny days and at night
- Depending on equipment, the information displayed may include navigation tips, speed, speed limits or settings for cruise control or DISTRONIC PLUS, for example
- Height position of the image, brightness and displayed content can be changed individually via a menu in the instrument cluster





## What's new: 8.4" COMAND Screen

\$2,330

Part of COMAND (531)

*Optional on all GLC*



Navigation, telephone, audio, video, internet – with the COMAND control and display system the driver is able to keep these and many other functions in view and under control. Information is shown in high resolution and in color on a large 8.4-inch media display. Operation via a touchpad is easy and intuitive.



# What's new: Exterior Comparison GLK vs. GLC

GLK Exterior



GLC Exterior

New radiator grill with two lamellas and central Mercedes Star



Integrated daytime running lights



# What's new: Exterior Comparison GLK vs. GLC

GLK Exterior



GLC Exterior

Standard roof rails

New rear lamp design





# What's new: Exterior Comparison GLK vs. GLC

GLK Exterior



GLC Exterior



Standard 18" wheels

Increased length, width and height



# What's new: Exterior/Interior Dimensions

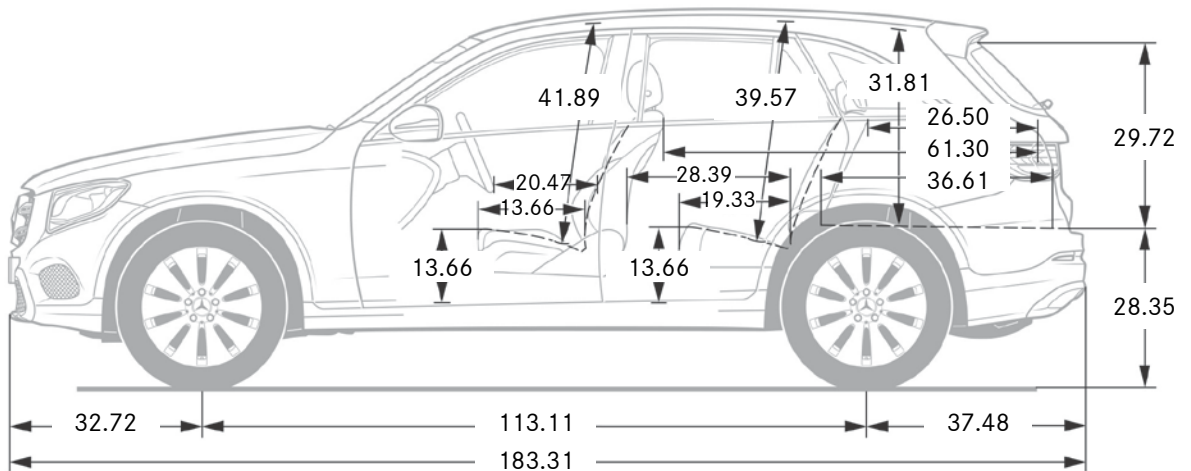
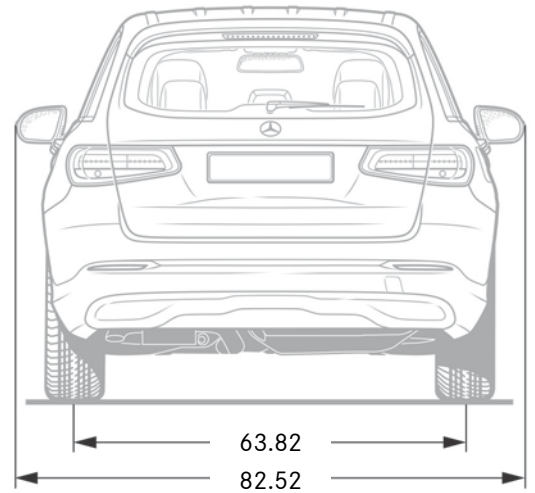
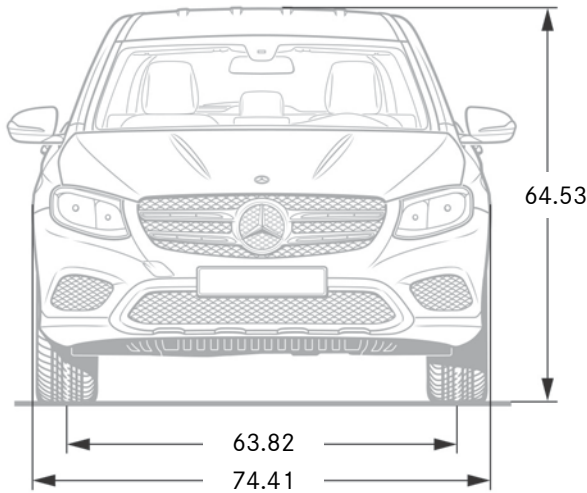

# What's new: Interior Comparison GLK vs. GLC

GLK Interior



GLC Interior

New designed center console

New 8.4" COMAND Screen



## Models

	Displacement	Power	Torque	MSRP	Launch
GLC300 (253.948)	tbd	tbd	tbd	tbd	Nov. 2015
GLC300 4M (253.949)	tbd	tbd	tbd	tbd	Nov. 2015



## Standard Equipment Highlights

### Performance/Handling

- 9 Speed Transmission
- DYNAMIC SELECT
- 2.0L turbo-4 (241 hp, 273 lb-ft)

### Comfort/Convenience

- KEYLESS-START
- Touchpad
- Power Driver Seat with Memory
- Rearview Camera
- Power Tailgate
- Power Folding Mirrors
- 7" Color Display
- Media Interface (iPod etc.)

### Safety/Security

- Collision Prev. Assist PLUS (CPA+)
- PRE-SAFE
- Crosswind Stabilization



# Paints

## Non-metallic Paints

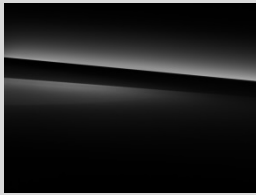

040  
Black

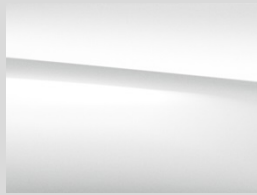

149  
Polar White

## Metallic Paints<sup>1</sup>

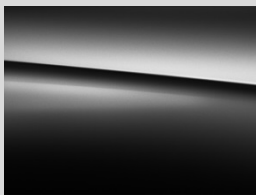

197  
Obsidian Black



775  
Iridium Silver

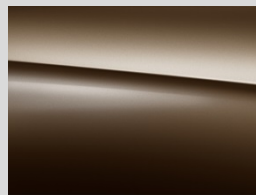

796  
Dakota Brown

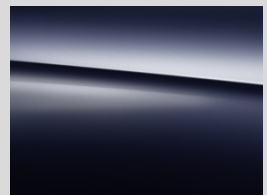

890  
Lunar Blue



992  
Selenite Grey

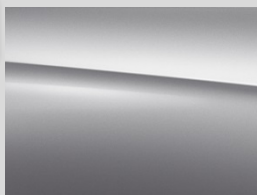

988  
Diamond Silver

## designo Metallic Paints<sup>\*\*</sup>

Metallic paint with high-quality effect pigments and exclusive color shades



271  
MAGNO Dakota  
Brown<sup>4</sup>

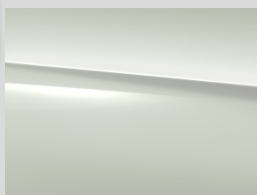

799  
Diamond White<sup>3</sup>



996  
Cardinal Red<sup>2</sup>

<sup>1</sup>Additional charges: \$720

<sup>2</sup>Additional charges: \$1,080

<sup>3</sup>Additional charges: \$1,515

<sup>4</sup>Additional charges: \$3,950





# Upholsteries

## Standard

MB-  
Tex



101 Black  
*Crystal Grey ( or Opt.  
Black) Headliner*



114 Espresso Brown/Black  
*Black Headliner*  
(only i.c.w. Sport Pkg 321)



115 Silk Beige/Black  
*Beige Headliner*

## Optional

Leather



221 Black  
*Crystal Grey ( or Opt.  
Black) Headliner*



224 Espresso Brown/Black  
*Black Headliner*



225 Silk Beige/Espresso  
Brown  
*Beige Headliner*



# Upholsteries

Optional



*designo*  
Exclusive Nappa Leather



971 *designo*  
Black/Black  
*Black Headliner*



975 *designo*  
Platinum White Pearl/Black  
*Black Headliner*





# Trims

## H07 – Linden Wood



Standard

## 731 – Burl Walnut Wood



Optional  
n/c

## 736 – Open-pore Black Ash Wood



Optional  
\$160



# Wheels

## Standard



R31 – 5-spoke  
All-Season & Run-Flat  
**18"**

## Optional



R48 – 5-spoke  
All-Season & Run-Flat  
**19"**

## Optional



638 – AMG Himalaya  
Grey 5-twin-spoke  
All-Season & Run-Flat  
**19"**  
(only i.c.w. Sport Pkg)

GLC300/ 4M



99R – AMG Black 5-  
twin-spoke  
All-Season & Run-Flat  
**19"**  
(only i.c.w. Night Pkg -  
Standard)



698 – AMG multi-  
spoke  
High-Performance &  
Run-Flat  
**20"**  
(only i.c.w. Night Pkg -  
Optional)



## Visual Equipment Differentiation

### Headlights

#### Halogen Headlamps including integral LED daytime running lamps (Standard)



- Reflection-type halogen headlamps offer high light intensity and a long service life. The LED daytime running lamps are integrated into the headlamps

#### LED Intelligent Light System (642- Optional)



The LED Intelligent Light System:

- All functions feature LED technology
- Automatic adaptation of headlamps to weather, lighting and driving conditions for ideal visibility in every situation
- variable low beam for country roads and motorways
- Automatically activated cornering lights
- Active light function for significantly better illumination in bends
- Enhanced fog lamp function for better orientation in poor visibility
- Distinctive look by day and night
- Long service life thanks to LED technology - no need for bulb changes
- Light color similar to that of daylight
- Low energy consumption
- Tail lights with LED technology
- Luminosity of the brake lights is varied according to the light conditions so as to avoid dazzling other road users



## Option Packages

### P01 – Premium Package \$1,850

- U80 – 115V AC power outlet
- 234 – Blind Spot Assist
- 536 – SiriusXM® Satellite Radio
- 873 – Heated Front Seats
- 889 – KEYLESS-GO

### 318 – Interior Package \$2,500

#### ***Requires P01 Package***

- 20X – Leather Upholstery
- 30P – Storage Package
- U09 – MB-Tex Covered Dashboard & Upper Door Panels w/Top-Stitching
- U25 – Illuminated Door Sills
- 401 – Ventilated Seats
- 877 – Ambient Lighting Package

### 319 – Lighting Package \$1,390

- 608 – Adaptive Highbeam Assist
- 640 – Full-LED Headlamps with Active Curve Illumination

### 320 – Multimedia Package \$2,330

- 531 – COMAND Navi w/ Single Disc
- 502 – Navigation Map Updates for 3 Years

### 321 – Sport Package \$2,950

- P31 – AMG Exterior Sport Package
- U09 – MB-Tex Covered Dashboard & Upper Door Panels w/Top-Stitching
- 638 – 19” AMG Wheel
- 772 – AMG body styling

## Option Packages (continued)

**521 – Night Package** **\$300**

***Requires 321 Sport Package***

- P55 – Night Package Code
- 99R – 19” Black AMG Wheel
- 698 – 20” Black AMG Wheel \$1,050

**996 – Advanced Parking Assist Package** **\$1,540**

- P44 – Parking Package
- P14 – Hands-free Package
- 235 – PARKTRONIC w/ Active Parking Assist

**997 – Driver Assistance Package** **\$2,800**

- 23P – Driver Assist Package
- 233 – DISTRONIC PLUS (with PRE-SAFE® Brake)
- 237 – Active Blind Spot Assist
- 238 – Active Lane Keeping Assist
- 253 – PRE-SAFE PLUS rear-end collision protection
- 266 – Steering Assist
- 268 – BAS PLUS w/ Cross-Traffic Assist



## Stand-Alone Options/Special Orders/Accessories

### Stand-Alone Options

234	Blind Spot Assist	\$550
242	Power Passenger Seat w/ Memory <i>Requires 318 Interior Package</i>	\$430
313	Rear Door Roller Blinds	\$380
413	Panorama sunroof <i>Standard Steel Roof</i>	\$1,480
443	Heated steering wheel	\$250
463	Head-up Display <i>Requires P01 Package</i>	\$990
489	AIRMATIC Air Suspension	\$1,610
536	SiriusXM Radio	\$460
550	Trailer Hitch <i>not i.c.w. 996 Advanced Parking Assist Package</i>	\$575
810	Burmester Surround Sound System	\$850
846	Brushed Aluminum Running Boards	\$670
872	Heated Rear Seats <i>Requires 873</i>	\$620
873	Heated Front Seats	\$580
P21	Air Balance	\$350
48R	19" 5-Spoke Wheel	\$500

### Special Order Options (additional charge of \$tbd)

293	Side Airbags in Rear with Belt Force Limiters	\$420
875	Heated Windshield Washing System	\$205
581	3-Zone Climate Control	\$790



# Specifications

	GLC300	GLC300 4M
Engine Configuration	Tbd	Tbd
Power (hp)		
Torque (lb-ft)		
Displacement (cc)		
Acceleration 0-60mph (sec)		
Fuel Economy (Cty/Hwy)		
Top Speed (mph)		
Fuel Requirement (Octane)		
# Valves per cylinder		
Compression		
Transmission		
Transmission Speeds		
Drive Configuration		
Standard Front Wheel		
Standard Rear Wheel		
Standard Front Tire Size		
Standard Rear Tire Size		
Standard Tire Type		
Fuel Tank Size (gallons)		
Trunk Size (cubic feet)		
Curb Weight (lbs)		
Vehicle Length (in.)		
Vehicle Width (in.)		
Vehicle Height (in.)		
Wheelbase		
Track Width Front/Rear (in.)		



## Product Highlights: COLLISION PREVENTION ASSIST PLUS

Standard on all models

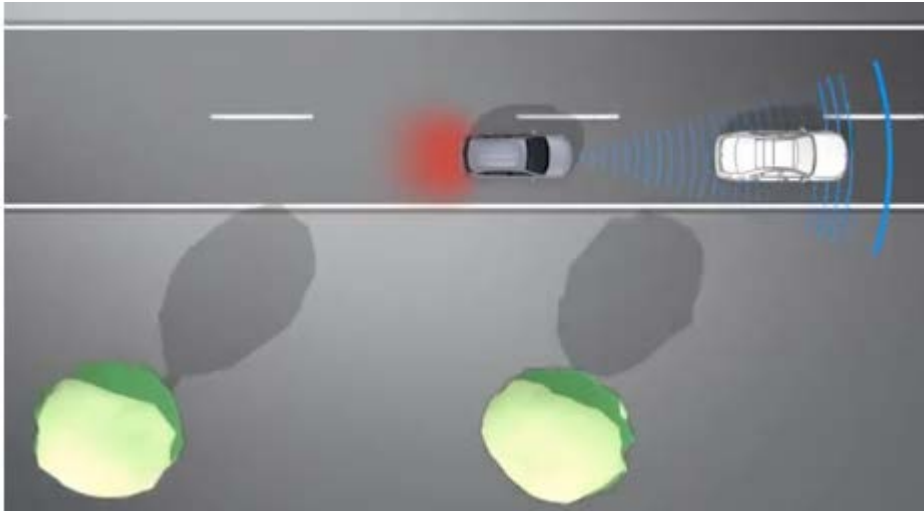

- Driving assistance system to lessen the danger of rear-end collisions and mitigate the consequences of accidents
- Combination of radar-based distance warning, assisted braking by Adaptive Brake Assist and autonomous partial braking
- Visual warning by means of a warning lamp in the instrument cluster when the safe distance to vehicles in front is too low within a speed range between 20 and 155 mph
- Additional audible warning if the distance diminishes rapidly
  - In the case of moving vehicles, in a speed range between 19 and 155 mph
  - In the case of stationary obstacles, in a speed range between 4 and 124 mph
- In case of emergency braking by the driver – and if necessary – increase in the brake pressure by Adaptive Brake Assist to prevent a collision
- Initiation of autonomous partial braking if the driver fails to react:
  - In the case of moving vehicles, in a speed range between 4 and 65 mph
  - In the case of stationary obstacles, in a speed range between 4 and 31 mph





## Product Highlights: PRE-SAFE

Standard on all models

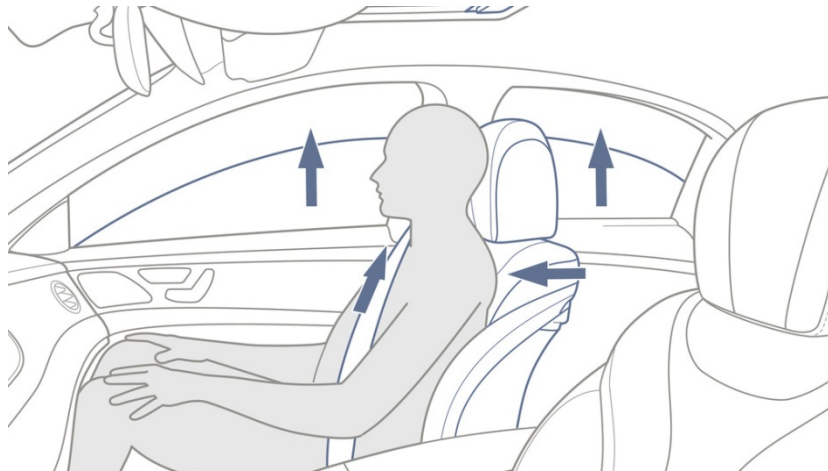

### **PRE-SAFE can be activated by the following situations:**

- Hard braking: the deceleration required by the driver is much greater than the physically possible vehicle deceleration on a slippery surface (hydroplaning, ice, snow).
- Critical steering movements: rapid steering movements at high speeds, which indicate a panic response by the driver and can destabilize the vehicle

### **PRE-SAFE is able to initiate the following measures:**

- Reversible preventive tensioning of the front seat belts by electric motors
- Open side windows and an open panoramic sunroof are almost completely closed when an imminent rollover is detected
- The front passenger seat is moved to a more favorable position for a possible impact. Repositioning depends on whether the occupant is wearing a seat belt or not, and whether a child seat has been detected.



## Product Highlights: CROSSWIND ASSIST

Standard on all models

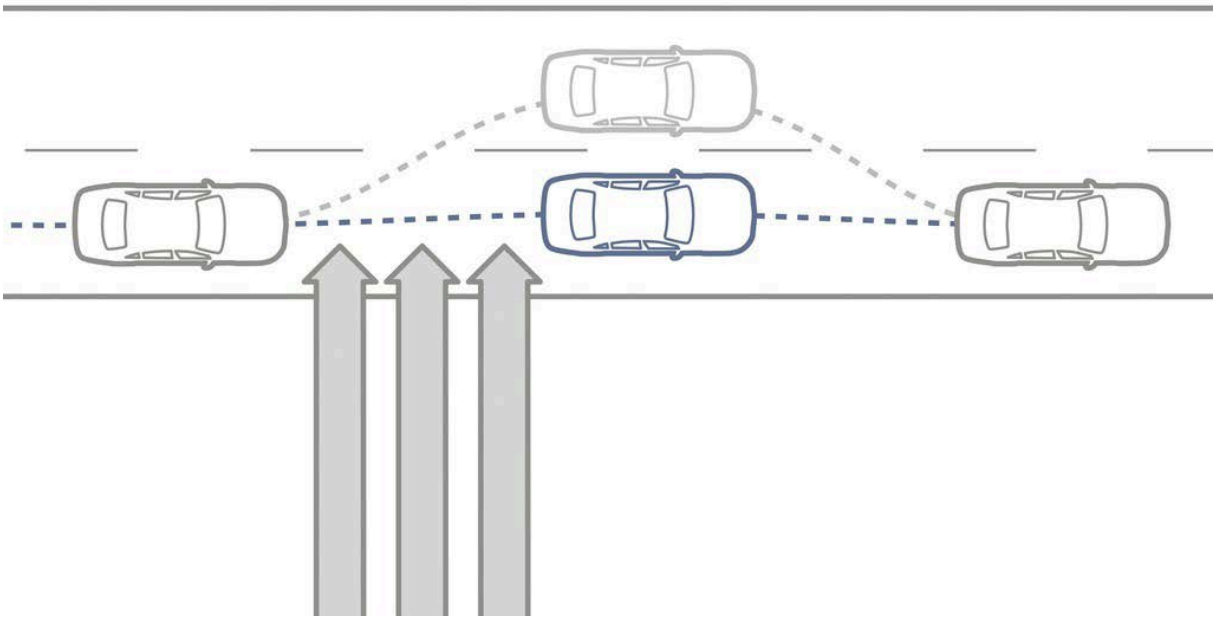

- Traditionally, strong gusts of wind may lead to sudden lateral drift of the vehicle
- Crosswind Assist aids the driver by reducing the vehicle's lateral drift substantially in windy driving conditions
- Crosswind Assist is integrated into the ESP® sensor system and enables the timely detection of gusts of crosswind
- Automatic brake intervention on the wheels on the side of the vehicle facing the wind results in a yaw motion which counteracts the crosswind
- Crosswind Assist substantially enhances the driver's sense of control, stability and safety
- Crosswind Assist is active from 50mph when driving straight ahead and on slight bends



## Product Highlights: Active Parking Assist including PARKTRONIC

Optional on all models



- Reduced strain on driver by helping to find a parking space
- Convenient entering and leaving of parking spaces thanks to active steering and braking intervention
- Parking possible also in small parking spaces and in several maneuvers
- Computation of a suitable trajectory from the vehicle's current position
- PARKTRONIC provides the driver with visual and audible warnings of obstacles in front of or behind the vehicle, thereby helping to avoid damage when maneuvering
- Driver intervention possible at any time (Parking Assist is deactivated automatically)



## Product Highlights: 4MATIC



A change of design has taken place with the combination of 4MATIC permanent all-wheel drive and 9G-TRONIC: the single-stage transfer case is now flange connected to the 9G-TRONIC as its own system. Previously the transfer case was integrated into the 7G-TRONIC PLUS. With the new add-on solution, it has been possible to combine the advantages of both designs and enhance performance



## Competitive advantages of the GLC

### Lexus NX



- Limited rear visibility
- Larger Dimensions (Length & Width)
- 9-Speed Automatic Transmission
- DYNAMIC SELECT Suspension
- COLLISION PREVENTION ASSIST +
- ATTENTION ASSIST
- PRE-SAFE
- mbrace

### BMW X3



- Updated Interior
- 9-Speed Automatic Transmission
- DYNAMIC SELECT Suspension
- COLLISION PREVENTION ASSIST +
- ATTENTION ASSIST
- PRE-SAFE
- mbrace

### Audi Q5



- Updated Interior
- 9-Speed Automatic Transmission
- DYNAMIC SELECT Suspension
- COLLISION PREVENTION ASSIST +
- ATTENTION ASSIST
- PRE-SAFE
- mbrace





# Gallery

101 – Black MB-Tex



114 – Espresso Brown/Black MB-Tex



# Gallery

221 – Black Leather



225 – Silk Beige/Espresso Brown Leather





# Gallery

971 – *designo* Black/Black Leather  
(Linden Wood Trim)



971 – *designo* Black/Black Leather  
(Linden Wood Trim)





# Gallery

877 - Ambient Lighting



877 - Ambient Lighting



# Gallery

Standard OFF-ROAD Exterior (front)



Standard OFF-ROAD Exterior (rear)



# Gallery

Optional Sport Package Exterior (front)



Optional Sport Package Exterior (front)





# Gallery

## Cargo Position



Load compartment with rear bench fully folded



# Gallery

234 – Leather Saddle Brown/Black\* (left & center seat folded)



234 – Leather Saddle Brown/Black\* (right seat folded)



\*Saddle Brown/Black upholstery n/a