

# Dealer Ordering Guide



## Mercedes-Benz MY17 GLC (X253)

MY17 GLC

## **An important note about this Guide:**

The information presented in this guide is based on the most current information available and is intended for internal use only. Mercedes-Benz reserves the right to make changes at any time, without notice, to colors, materials, equipment, special specifications and models. Pricing may not yet be finalized for some models or options.

Due to variances among monitors and printers the colors that appear on your screen and printouts may not be exact.

For illustrative purposes, some images may show vehicles with European Specification.

## Revision History

Date	Changes
04/1/2016	Initial release
04/11/2016	Updated <i>designo</i> Pkgs
04/14/2016	Updated Package Descriptions
04/27/2016	Updated Trailer Hitch Rating
05/02/2016	Updated Head-Up Display Availability
05/26/2016	Addition of the GLC43 & GLC300 Package/Option Pricing.
05/31/2016	Updated standard steering wheel for GLC43
06/06/2016	Updated pricing of 521 Night Package
06/07/2016	Updated Trim Offerings
06/13/2016	Removed AMG Performance Exhaust (U78) option for GLC43 & 3-Zone Climate Control (581) for all models
06/14/2016	Updated Wheel Offerings with R96 Wheel & Removed 430 Off Road Engineering Package
06/16/2016	Addition of L6K – AMG Performance Steering Wheel, updated availability for 443 – heated steering wheel, updated availability of 555 seats with <i>designo</i> upholstery.
06/20/2016	Updated Sport Model description to include Perforated Front Brake Disks and front brake calipers with “MB” lettering
06/21/2016	Discontinuation of codes L6K – AMG Performance Steering Wheel and 555 seats until further notice.
06/21/2016	Added image of 632 LED Headlamps to Visual Differentiations
06/22/2016	Updated availability of 242 with leather upholstery and updated AMG pricing.
06/23/16	Removed 430 Off Road Engineering Pkg. from “What’s New: MY17 Overview” Slide

## Revision History (cont.)

Date	Changes
06/29/2016	Removed P02 Premium Package, adjusted cumulative Premium Package (P03 & P04) pricing accordingly
06/30/2016	Included 632 - LED Headlamps as Stand-Alone Option
	Package Pricing Added
07/28/2016	Removed 430 - Off-Road Engineering Package from DOG
8/1/2016	Added Seating Package (318) for AMG GLC 43
8/3/2016	Content and formatting revision. Updated Top Speed and kerb weight for the GLC43
8/5/2016	Updated wood trim offerings for all variants and added package and option pricing for AMG GLC43
8/8/2016	Added image of the accessory roof spoiler in the Gallery section
8/11/2016	Updated DOG to new DOG Template
8/12/2016	Updated nomenclature
8/23/2016	Removed Leather Seating Package (318) on GLC43. Leather is available as a standalone option for this model.
8/24/2016	Updated description for 521 - Night Package for AMG model
8/31/2016	Updated trim pricing for AMG GLC43
9/7/2016	Added Rear Side Airbags (293) under SPC options for all variants
9/9/2016	Updated Aluminum Trim description (739)
9/21/2016	Added components of the Hands-Free Package (P17) within the Advanced Parking Assist Package (996)

## Table of Contents

- [Models](#)
- [Specifications](#)

### **Mercedes-Benz :**

- [What's new in MY 17](#)
- [Standard Equipment](#)
- [Paints](#)
- [Upholsteries](#)
- [Trims](#)
- [Wheels](#)
- [Option Packages](#)
- [Stand-Alone Options/Special Orders/Accessories](#)
- [Visual Equipment Differentiation](#)
- [Product Highlights](#)
- [Gallery](#)

### **Mercedes-AMG:**

- [What's new in MY 17](#)
- [Standard Equipment](#)
- [Paints](#)
- [Upholsteries](#)
- [Trims](#)
- [Wheels](#)
- [Option Packages](#)
- [Stand-Alone Options/Special Orders/Accessories](#)
- [Visual Equipment Differentiation](#)
- [Product Highlights](#)
- [Gallery](#)

## Models

	Engine	Power	Torque	MSRP	Launch
GLC300 (253.948)	2.0L Turbo-4	241 @ 5,500	273 @ 1,300- 4,000	\$39,150	Aug. 2016
GLC300 4M (253.949)	2.0L Turbo-4	241 @ 5,500	273 @ 1,300- 4,000	\$41,150	Aug. 2016
AMG GLC 43 (253.964)	AMG Enhanced 3.0L V6 Biturbo	362@ 6,000	384@ 2,500- 4,500	\$54,900	Oct. 2016



# Specifications

	GLC300	GLC300 4M	AMG GLC43
Engine Configuration	2.0L Turbo-4	2.0L Turbo-4	AMG Enhanced 3.0L V6 Biturbo
Power (hp)	241	241	362
Torque (lb-ft)	273	273	384
Displacement (cc)	1,991	1,991	2,996
Acceleration 0-60mph (sec)	6.3	6.4	4.8
Fuel Economy (Cty/Hwy)	22/28	21/28	TBD
Top Speed (mph)	130 (lim.)	130 (lim.)	130 (lim.)
Fuel Requirement (Octane)	91	91	91
# Valves per cylinder	4	4	4
Compression	9.8 : 1	9.8 : 1	10.7 : 1
Transmission	9G-TRONIC	9G-TRONIC	9G-TRONIC
Transmission Speeds	9	9	9
Drive Configuration	Rear-Wheel Drive	All-Wheel Drive	All-Wheel Drive
Standard Front Wheel	8 J x 18	8 J x 18	8.5 J x 20
Standard Rear Wheel	8 J x 18	8 J x 18	9.5 J X 20
Standard Front Tire Size	235/60 R18	235/60 R18	255/45 R20
Standard Rear Tire Size	235/60 R18	235/60 R18	285/40 R20
Standard Tire Type	All Season	All Season	All Season
Fuel Tank Size (gallons)	17.4	17.4	17.4
Trunk Size (cubic feet)	56.5	56.5	56.5
Curb Weight (lbs)	3,891	4,001	4,145
Vehicle Length (in.)	183.3	183.3	183.5
Vehicle Width (in.)	74.4	74.4	76.0
Vehicle Height (in.)	64.5	64.5	64.1
Wheelbase	113.1	113.1	113.1
Track Width Front/Rear (in.)	63.9/63.7	63.9/63.7	64.5/ 65.2
Towing Capacity (lbs.)	3,500	3,500	3,500





## **GLC300, GLC300 4M Ordering Guide**



## What's new: MY17 Overview

### Standard Equipment

- GARMIN Pre-Wiring

### Optional Equipment

- New Premium Package Structure
- Introduction of LED Headlamps
- Touchpad only available with COMAND

### Paints

- Addition of Brilliant Blue Metallic Paint (896)

### Upholsteries

- Addition of Saddle Brown Leather (234)



## What's new: Premium Package Structure

With added components moving to standard equipment the Premium Packages are now delighting customers with expanded content at a lower price.

### MY 16

#### Premium 1 Package

- SiriusXM Radio
- KEYLESS GO
- 115V Power Outlet
- Blind Spot Assist
- Heated Front Seats
- **MSRP \$1,850**

#### Multimedia Package

- COMAND Navi w/ Single Disc
- Navigation Map Updates for 3 Years
- **MSRP \$2,330**

#### Lighting Package

- Adaptive Highbeam Assist
- Active LED Headlamps w/ Active Curve Illumination
- **MSRP \$1,500**

#### Interior Package

- Leather Upholstery
- MB-TEX Dashboard
- Storage Pkg
- Illuminated Doorsills
- Ventilated Seats
- Ambient Lighting Pkg
- **MSRP \$3,150**

### MY 17

#### Premium 1 Package

- SiriusXM Radio
- KEYLESS-GO
- 115V Power Outlet
- Blind Spot Assist
- Heated Seats
- **MSRP \$ 1,830**

#### Premium 2 Package

- *Premium 1, plus:*
- COMAND Navi w/ 8.4" Screen
- Navigation Map Updates for 3 Years
- Touchpad
- Ambient Lighting (W/Doorsills)
- Storage Package
- **MSRP \$ 4,180**

#### Premium 3 Package

- *Premium 2, plus:*
- Driver Assistance Pkg.
- Active LED Headlamps
- AIR BALANCE
- **MSRP \$ 7,780**

## What's new: 321 – Sport Package

\$1,900

*Optional on GLC300 models. Not available on GLC43.*



Added sportiness, exclusivity and fun at the wheel are all part of the perfectly coordinated package of equipment that makes up the AMG Line Exterior.

The Sport Package includes:

- ① AMG body styling consisting of AMG front and rear apron
- ② 19" AMG 5-Spoke Wheels (638)
- ③ Perforated front brake discs & front brake calipers w/ 'MB' lettering
- ④ MB-Tex Covered Dashboard & Upper Door Panels w/Top-Stitching



## What's new: 521 – Night Package

**\$300**

*Requires 321 Sport Package.*



Striking design features in black underscore the sporty, expressive character of the vehicle

The Night Package includes:

- ① Radiator trim with integral Mercedes star and two lamellas in high-gloss black with chrome inserts
- ② 19" AMG Twin 5-Spoke Wheels painted in high-gloss black with a high-sheen finish (99R)
  - Wheel Shown is Optional: 20" AMG multi-spoke light-alloy high performance wheels painted in high-gloss black with high-sheen finish (698) **(\$1,050)**
- ③ Roof rails powder-coated in matte black
- ④ Under guard front/rear painted in black
- ⑤ Exterior mirrors painted in high-gloss black
- ⑥ Waistline trim strip and window weather strip in high-gloss black



## What's new: DYNAMIC SELECT

*Standard on the GLC300/300 4M.*



At a touch of the DYNAMIC SELECT feature, drivers can choose between comfortable, sporty, particularly sporty and efficient driving styles, or their own individually defined style. Parameters such as the engine, transmission and steering characteristics are adjusted according to the selected drive mode.

### Choice of up to 5 different driving programs:

1. "Comfort" standard setting: well-balanced and fuel-efficient
2. "Eco" mode: for keeping fuel consumption as low as possible
3. "Sport" mode: added agility and dynamism thanks to a more direct steering characteristic curve, sporty, taut suspension tuning (in conjunction with AIR BODY CONTROL air suspension), spontaneous throttle response and modified shift points (with 9G-TRONIC PLUS)
4. "Sport+" mode: even sportier performance, the suspension (in conjunction with AIR BODY CONTROL air suspension) and drive system have an even more dynamic setup
5. "Individual" mode: individual parameters can be varied as required, using the Controller and the configuration menu in the head unit



## What's new: 9G-TRONIC

*Standard on all GLC models.*



### **9G-TRONIC – faster, smoother, more efficient**

Featuring nine forward gears, this automatic transmission takes efficiency, comfort and dynamism to a completely new level. It is the world's first 9-speed automatic transmission with hydrodynamic torque converter in the premium segment. The larger ratio range allows a reduction in engine speed. Performance remains excellent while ride comfort is enhanced and noise levels are reduced. The reduced intervals between the gears lead to faster gear changes and enhanced spontaneity and agility. At the same time, the 9G-TRONIC impresses with smooth, barely perceptible gear shifting like that of a continuously variable transmission. As the 9G-TRONIC is able to skip individual gears, multiple downshifts are possible for fast and powerful sprints.





## What's new: 448 – Touchpad

*Optional on all GLC models (Included in Premium 2 Package)*



The functions of COMAND can be controlled intuitively via the innovative touchpad, using single or multiple-finger gestures (multi-touch).

- Touchpad approx. 2.56 x 1.77 inches in size and comfortable hand rest in one single component
- Additional full-fledged input option for COMAND Online and Audio 20 CD in addition to the COMAND Controller and Voice Control
- Recognizes single and multiple-finger gestures (multi touch), swiping movements and zoom gestures achieved by spreading the fingers or pinching them together
- Innovative handwriting recognition feature: Users are able to input letters, special characters and numbers in their normal handwriting, in any language available in the head unit
- 3 buttons located behind the touchpad allow fast and direct operation of important functions
- Clear haptic feedback when using the touchpad or keys



## What's new: 463 – Head-Up Display

Delayed Availability

*Optional on all GLC models (Requires Premium 1 Package)*



The Head-Up Display at a glance:

- Key driver information at a glance, without the driver having to take their eyes off the road
- Projection of a virtual image measuring approx. 8.3 x 2.8 inches into the driver's field of vision, which appears to float around 78.7 inches in front of him/her above the bonnet
- Presentation of information in high-resolution and in color, making it clearly legible even on sunny days and at night
- Depending on equipment, the information displayed may include navigation tips, speed, speed limits or settings for cruise control or DISTRONIC PLUS, for example
- Height position of the image, brightness and displayed content can be changed individually via a menu in the instrument cluster





## What's new: 8.4" COMAND Screen

*Optional on all GLC models (Included in Premium 2 Package)*



Navigation, telephone, audio, video, internet – with the COMAND control and display system the driver is able to keep these and many other functions in view and under control. Information is shown in high resolution and in color on a large 8.4-inch media display. Operation via a touchpad is easy and intuitive.



# What's new: Exterior/Interior Dimensions

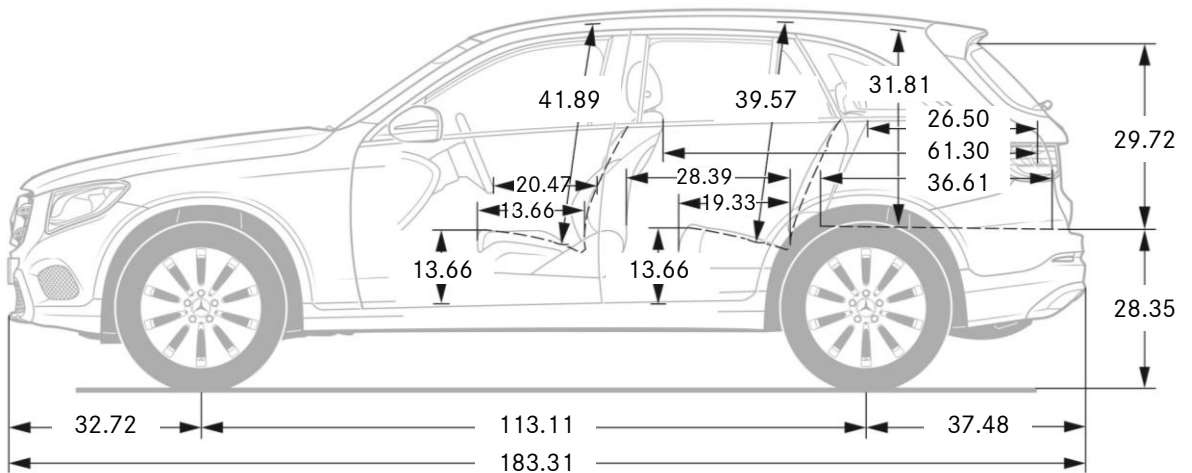
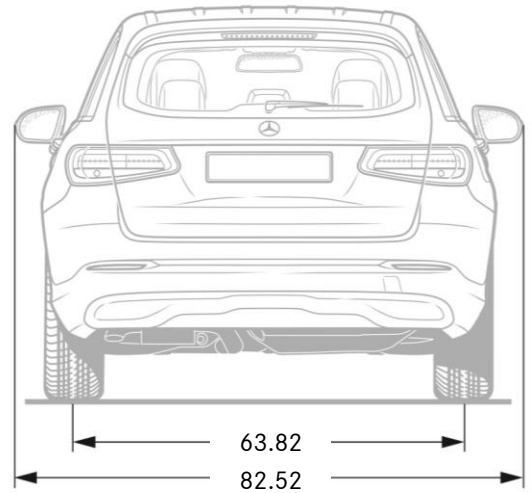
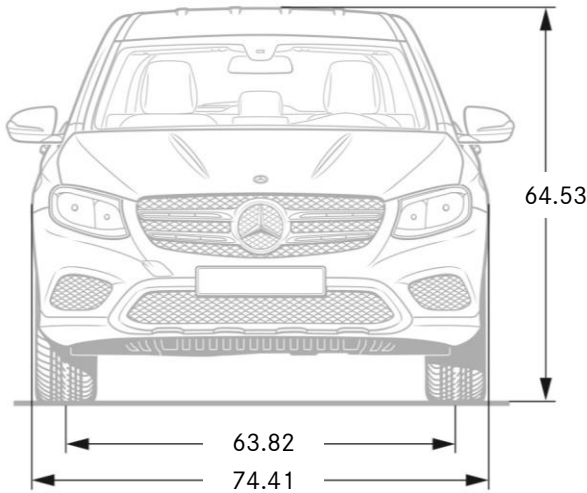

## Standard Equipment Highlights

### Performance/Handling

- 9G-TRONIC 9-speed automatic transmission
- DYNAMIC SELECT
- 2.0L Turbo-4 (241 hp, 273 lb-ft)
- Start/Stop Technology

### Comfort/Convenience

- KEYLESS-START
- Power Driver Seat with Memory
- Rearview Camera
- Power Tailgate
- Power Folding Mirrors
- Auto-Dimming Driver & Rear View Mirror
- FrontBass® speed-sensitive five speaker sound system
- Multifunction leather steering wheel
- Central Controller with 7" high-mounted tablet-style color display
- Bluetooth Technology (for Handsfree Phone Use/Audio Streaming)
- GARMIN Pre-Wiring

### Safety/Security

- Collision Prevention Assist PLUS (CPA+)
- 3-point Seat Belt with Pretensioners & Dual-Stage Belt Force Limiter
- PRE-SAFE
- Crosswind Assist
- ATTENTION ASSIST Driver Drowsiness Monitor
- Tire Pressure Monitoring System
- ISOFIX Anchor and Tether System
- Anti-theft Alarm System
- Smart Key with Panic Button
- 24h Roadside Assistance Program



# Paints\*

## Non-metallic Paints



040  
Black



149  
Polar White

## Metallic Paints<sup>1</sup>

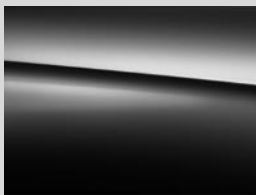

197  
Obsidian Black

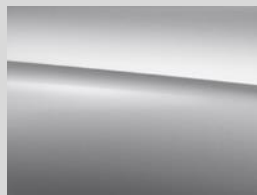

775  
Iridium Silver



796  
Dakota Brown

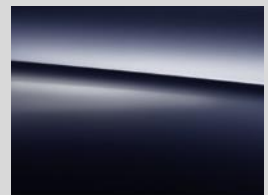

890  
Lunar Blue



896  
Brilliant Blue



992  
Selenite Grey

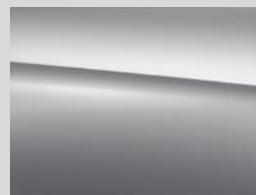

988  
Diamond Silver

## designo Metallic Paints



Metallic paint with high-quality effect pigments and exclusive color shades

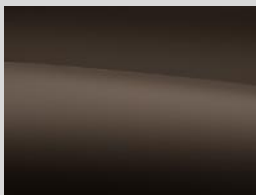

271  
Dakota Brown  
Magno<sup>2</sup>



996  
Cardinal Red<sup>3</sup>



799  
Diamond White<sup>4</sup>

<sup>1</sup>Additional charges: \$720

<sup>2</sup>Additional charges: \$3,950

<sup>3</sup>Additional charges: \$1,080

<sup>4</sup>Additional charges: \$1,515



# Upholsteries

Standard on GLC300, 3004M

MB-**Tex**



101 Black



114 Espresso Brown/Black  
(requires Sport Pkg 321)



115 Silk Beige/Black

Upholstery Code	101 Black MB-TEX	114 Brown/ Black MB-TEX	115 Beige/ Black MB-TEX
<b>Floor Mats</b>	Black	Black	Black
<b>Dashboard</b>	Black	Espresso Brown	Black
<b>Seat Belts</b>	Black	Black	Silk Beige
<b>Steering Wheel</b>	Black	Espresso Brown	Black
<b>Headliner</b>	Black or Crystal Grey	Black	Silk Beige



# Upholsteries

Optional on GLC300, 3004M

Leather



221 Black



224 Espresso Brown/Black



225 Silk Beige/Esspresso Brown



234 Saddle Brown/Black

new

Upholstery Code	221 Black Leather	224 Brown/Black Leather	225 Beige/Brown Leather	234 Brown/Black Leather
Floor Mats	Black	Espresso Brown	Espresso Brown	Black
Dashboard	Black	Espresso Brown	Espresso Brown	Black
Seat Belts	Black	Black	Silk Beige	Black
Steering Wheel	Black	Espresso Brown	Espresso Brown	Black
Headliner	Black or Crystal Grey	Black	Silk Beige	Black



# Upholsteries

Optional



*designo*  
Nappa Leather



P87 *designo*  
Black/Black  
**\$3,950**  
(requires P02 or P03)

P62 *designo*  
Platinum White/Black  
**\$3,950**  
(requires P02 or P03)

Upholstery Code	P87 Designo Black Nappa Leather	P62 Designo Platinum White/Black Nappa Leather
Floor Mats	Black	Black
Dashboard	Black	Black
Seat Belts	Silver	Silver
Steering Wheel	Black	Black
Headliner	Black	Black





## Trims

### H07 – Dark Brown Linden Wood



Standard  
Limited Availability

### H24 – Light Brown Linden Wood



Optional  
n/c

### 731 – Burl Walnut Wood



Optional  
n/c  
Limited Availability

### 736 – Natural Grain Black Ash Wood

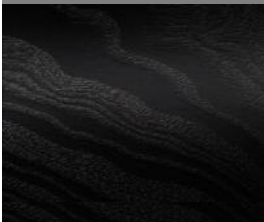

Optional  
\$160  
Limited Availability

### 739 – Brushed Aluminum Door Trim



- No-cost option
- Features High-Gloss Black center console **unless** *designo* Platinum White/Black Nappa leather package is selected (P62).
- When P62 is selected, the center console features Natural Grain Black Ash Wood trim.





# Wheels

GLC300/ 4M

Standard



R31 – 5-spoke  
All-Season & Extended  
Mobility  
**18"**



R96 – 5-spoke  
All-Season &  
Extended Mobility  
**18"**

Optional



48R – 5-spoke  
All-Season & Extended  
Mobility  
**19"**



99R – AMG 5-twin-  
spoke w/ Black inserts  
All-Season &  
Extended Mobility  
**19"**  
(requires Night Pkg -  
Standard)

Optional



638 – AMG Himalaya  
Grey 5-twin-spoke  
All-Season &  
Extended Mobility  
**19"**  
(requires. Sport Pkg)



698 – AMG multi-  
spoke w/ Black inserts  
High-Performance &  
Extended Mobility  
**20"**  
(requires Night Pkg -  
Optional)



## Option Packages

### P01 – Premium 1 Package

GLC300/4M: \$1,830

*Requires Heated Front Seats (873) or Heated/Ventilated Front Seats (401).*

- 536 – SiriusXM® Satellite Radio
- 234 – Blind Spot Assist
- U80 – 115V AC power outlet
- 889 – KEYLESS-GO

### P02 – Premium 2 Package

GLC300/4M: \$4,180

*Requires Heated Front Seats (873) or Heated/Ventilated Front Seats (401)*

*Requires Burmester Surround Sound System (810)*

*Not with (P01) Premium 1 Package, or (P03) Premium 3 Package*

*Includes all (P01) Premium 1 Package features plus:*

- 531 – COMAND Navigation w/ 8.4” Screen
- 502 – Navigation Map Updates for 3 Years
- 5 years Traffic and Weather Services (provided by SiriusXM®)
- 448 – Touchpad
- 877 – Ambient Lighting (Including Doorsills)
- 30P – Storage Package
  - Tensioning strap in the stowage compartment in the center console
  - Map pockets on the rear of the front seats
  - Net on the load compartment floor
  - Collapsible box under luggage compartment floor
  - Power release for rear backrests next to the rear seats, left and right

### P03 – Premium 3 Package

GLC300/4M: \$7,780

*Requires Heated Front Seats (873) or Heated/Ventilated Front Seats (401)*

*Requires Burmester Surround Sound System (810)*

*Not with (P01) Premium 1 Package, or (P02) Premium 2 Package*

*Includes all (P02) Premium 2 Package features plus:*

- 233 – DISTRONIC PLUS with Steering Assist
- 237 – Active Blind Spot Assist (*replaces 234 – Blind Spot Assist*)
- 238 – Active Lane Keeping Assist
- 253 – PRE-Safe Plus
- P21 – AIR BALANCE
- 640 – Active LED Headlamps
- 608 – Adaptive Highbeam Assist

## Option Packages (cont.)

### 318 – Leather Seating Package

\$1,900

*Requires MB-Tex Dashboard (U09) - \$350*

- 20X – Leather Upholstery
- 242 – Power Passenger Seat w/ Memory

### 321 – Sport Package

\$1,900

*GLC300/3004M Only*

- P31 – AMG Exterior Sport Package
- U09 – MB-Tex Covered Dashboard & Upper Door Panels w/Top-Stitching
- U29 – Perforated front brake disks & front brake calipers w/ ‘MB’ lettering
- 638 – 19” AMG Wheel
- 772 – AMG body styling

### 521 – Night Package

\$300

*Requires 321 Sport Package*

- P55 – Night Package Code
- 99R – 19” Black AMG Wheel
- 698 – 20” Black AMG Wheel

\$1,050

### 996 – Advanced Parking Assist Package

\$1,550

*Requires P02 or P03 Package*

- P44 – Parking Package w/ Surround View System
- P17 – Hands-free Package
  - KEYLESS-GO access and drive authorization system
  - Fully automatic luggage compartment door
  - HANDS-FREE ACCESS
  - Convenience opening and closing
  - Handle recess illumination
- 235 – PARKTRONIC w/ Active Parking Assist

## Stand-Alone Options

Stand-Alone Options (GLC300/3004M)		
234	Blind Spot Assist	\$550
313	Rear Door Roller Blinds	\$380
401	Heated/Ventilated Front Seats <i>Requires 318 Package</i>	\$1,030
413	Panorama Roof <i>Standard Steel Roof</i>	\$1,480
443	Heated steering wheel <i>Available with these interiors only for GLC300/4M - 101, 115, 221, P87</i>	\$250
463	Head-Up Display <i>Requires P01 Package</i>	\$990
489	AIR BODY CONTROL Air Suspension	\$1,900
536	SiriusXM Radio	\$460
550	Trailer Hitch - Class II Hitch <i>Not with 996 Advanced Parking Assist Package</i>	\$575
632	LED Headlamps <i>Requires P01 or P02 package</i> <i>Limited Availability</i>	\$850
810	Burmester Surround Sound System	\$850
846	Brushed Aluminum Running Boards	\$670
872	Heated Rear Seats <i>Requires 873</i>	\$620
873	Heated Front Seats	\$580
P21	Air Balance	\$350
48R	19" 5-Spoke Wheel	\$500
U09	MB-TeX Dashboard <i>Required for 318 Leather Pkg. Already included in 321 Pkg.</i>	\$350

## Special Orders/Accessories

### MB Accessories

03A	SD-Card for GARMIN® Map Pilot Navigation	\$625
00A	Illuminated Star <sup>1</sup>	\$550
068	Wheel Locks	\$140
070	Chrome Door Handles	\$100
105	Roof Spoiler <sup>2</sup>	\$350

### Special Order Options (additional charge of \$250)

293	Rear Side Airbags	\$420
875	Heated Windshield Washing System	\$205

<sup>1</sup> Not available with Premium 3 package

<sup>2</sup> Image provided in the Gallery section



## Visual Equipment Differentiation – Headlights

### Halogen Headlamps including integral LED daytime running lamps (Standard)



- Reflection-type halogen headlamps offer high light intensity and a long service life. The LED daytime running lamps are integrated into the headlamps

### LED Headlamps (632 - Optional)



- All functions feature LED technology
- Distinctive look by day and night
- Tail lights with LED technology

### Active LED Headlamps (640 - Optional)



- All functions feature LED technology
- Automatically activated cornering lights
- Active light function for significantly better illumination in bends
- Distinctive look by day and night
- Long service life thanks to LED technology - no need for bulb changes
- Light color similar to that of daylight
- Low energy consumption
- Taillamps with LED technology

## Product Highlights: COLLISION PREVENTION ASSIST PLUS

Standard on all models

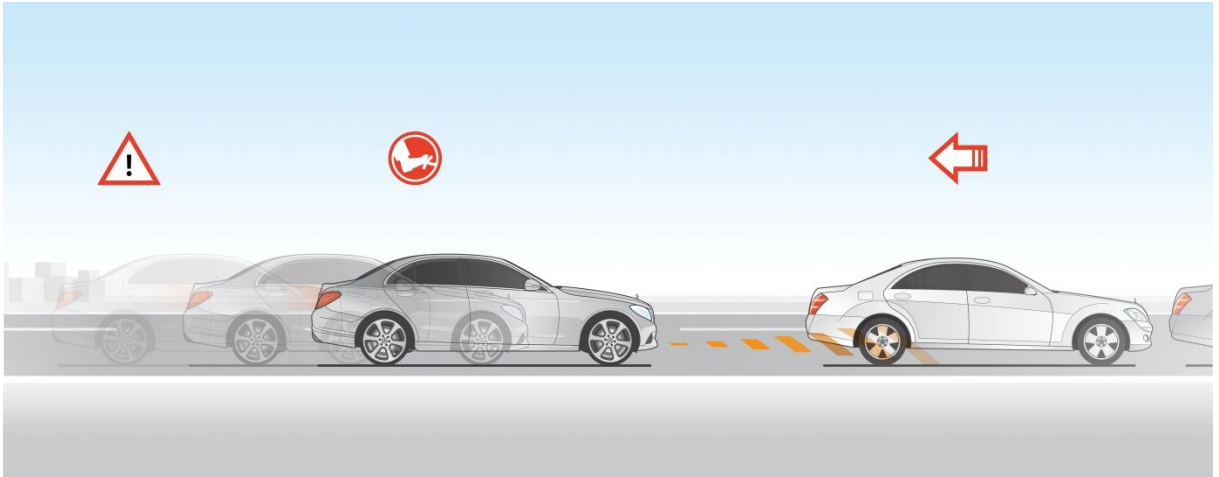

- Driving assistance system to lessen the danger of rear-end collisions and mitigate the consequences of accidents
- Combination of radar-based distance warning, assisted braking by Adaptive Brake Assist and autonomous partial braking
- Visual warning by means of a warning lamp in the instrument cluster when the safe distance to vehicles in front is too low within a speed range between 20 and 155 mph
- Additional audible warning if the distance diminishes rapidly
  - In the case of moving vehicles, in a speed range between 19 and 155 mph
  - In the case of stationary obstacles, in a speed range between 4 and 124 mph
- In case of emergency braking by the driver – and if necessary – increase in the brake pressure by Adaptive Brake Assist to prevent a collision
- Initiation of autonomous partial braking if the driver fails to react:
  - In the case of moving vehicles, in a speed range between 4 and 65 mph
  - In the case of stationary obstacles, in a speed range between 4 and 31 mph



## Product Highlights: PRE-SAFE

Standard on all models

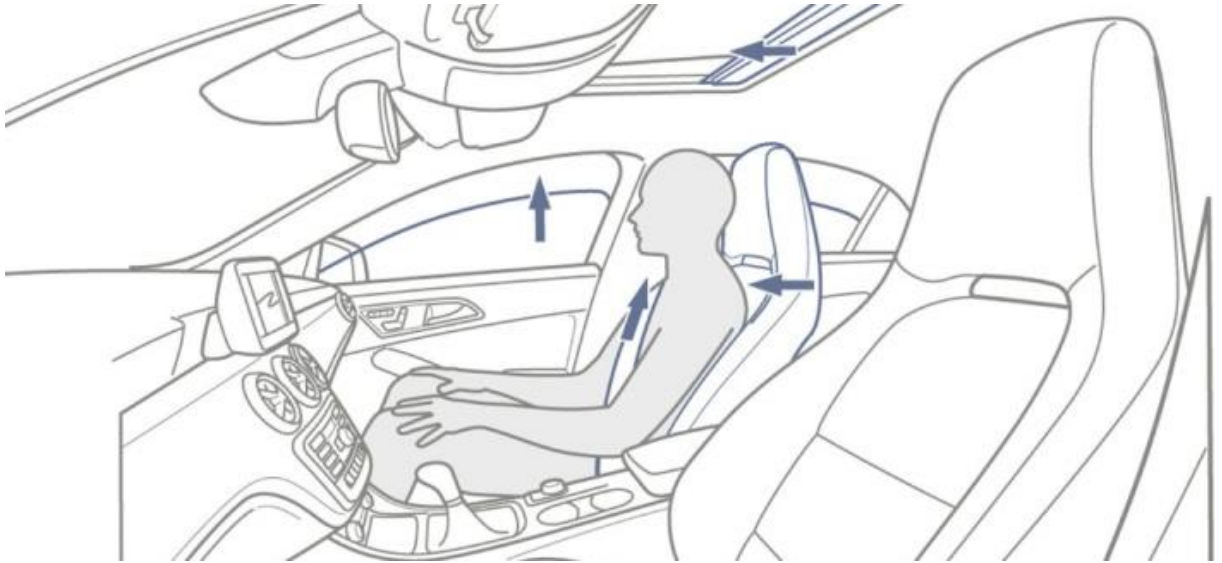

### **PRE-SAFE can be activated by the following situations:**

- Hard braking: the deceleration required by the driver is much greater than the physically possible vehicle deceleration on a slippery surface (hydroplaning, ice, snow).
- Critical steering movements: rapid steering movements at high speeds, which indicate a panic response by the driver and can destabilize the vehicle

### **PRE-SAFE is able to initiate the following measures:**

- Reversible preventive tensioning of the front seat belts by electric motors
- Open side windows and an open panoramic sunroof are almost completely closed when an imminent rollover is detected
- The front passenger seat is moved to a more favorable position for a possible impact. Repositioning depends on whether the occupant is wearing a seat belt or not, and whether a child seat has been detected.





## Product Highlights: Crosswind Assist

Standard on all models

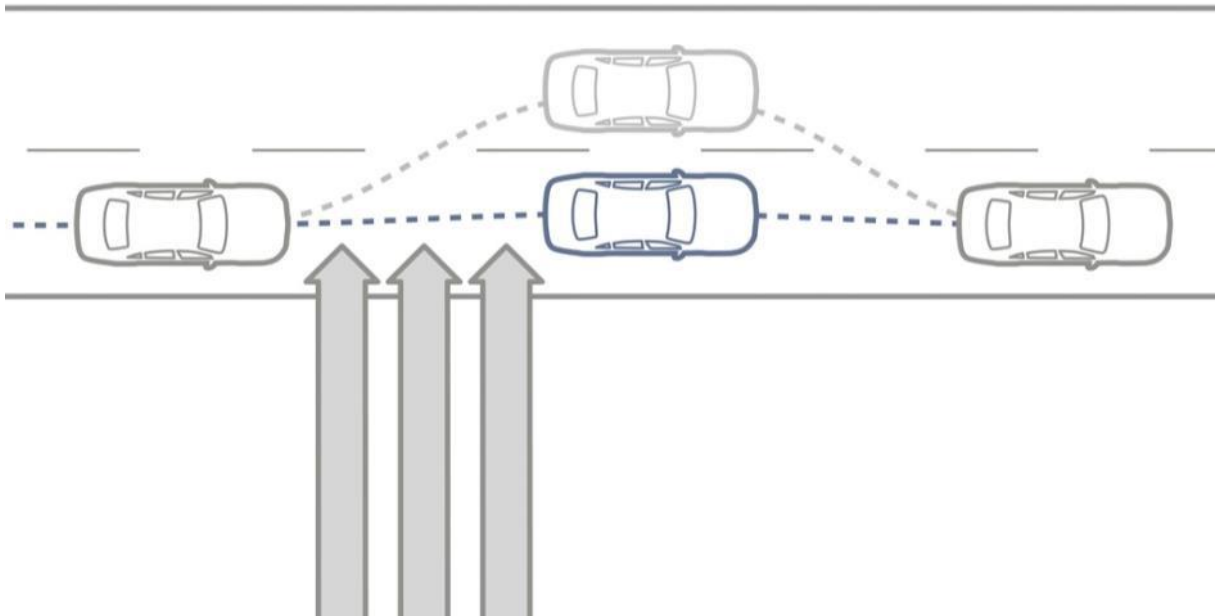

- Traditionally, strong gusts of wind may lead to sudden lateral drift of the vehicle
- Crosswind Assist aids the driver by reducing the vehicle's lateral drift substantially in windy driving conditions
- Crosswind Assist is integrated into the ESP® sensor system and enables the timely detection of gusts of crosswind
- Automatic brake intervention on the wheels on the side of the vehicle facing the wind results in a yaw motion which counteracts the crosswind
- Crosswind Assist substantially enhances the driver's sense of control, stability and safety
- Crosswind Assist is active from 50mph when driving straight ahead and on slight bends



## Product Highlights: 235 – PARKTRONIC w/ Active Parking Assist

Optional on all models



- Reduced strain on driver by helping to find a parking space
- Convenient entering and leaving of parking spaces thanks to active steering and braking intervention
- Parking possible also in small parking spaces and in several maneuvers
- Computation of a suitable trajectory from the vehicle's current position
- PARKTRONIC provides the driver with visual and audible warnings of obstacles in front of or behind the vehicle, thereby helping to avoid damage when maneuvering
- Driver intervention possible at any time (Parking Assist is deactivated automatically)



## Product Highlights: 4MATIC



A change of design has taken place with the combination of 4MATIC permanent all-wheel drive and 9G-TRONIC: the single-stage transfer case is now flange connected to the 9G-TRONIC as its own system. Previously the transfer case was integrated into the 7G-TRONIC PLUS. With the new add-on solution, it has been possible to combine the advantages of both designs and enhance performance



## Product Highlights: 489 – AIR BODY CONTROL

Optional on GLC300/4M



- Multi-chamber air suspension combined with continuously adjustable damping to improve ride comfort and driving dynamics
- Vehicle characteristics can be varied from comfortable through to sporty using DYNAMIC SELECT switch
- "Comfort" and "Sport" settings for a more comfortable or stiffer, sportier setup
- Constant vehicle level irrespective of load thanks to pneumatic all-round self-levelling suspension
- Suspension level can be raised for poor surfaces and is automatically lowered at high speeds
- It is possible to lower the vehicle level by 1.6 inches to make it easier to load the luggage compartment. (Function activated by means of switch in luggage compartment side trim)



## Product Highlights: 810 – Burmester Surround Sound System

Optional on all models



- 13 high-performance speakers precisely configured for the vehicle interior to ensure well-balanced and very dynamic music reproduction
- 9-channel DSP amplifier with a total output of 590 watts (7 x 50 W and 2 x 120 W) for maximum sound quality with very high volume reserves
- Frontbass® technology with woofers integrated into the body shell for vibrant bass reproduction
- Combination of digital and analogue filter elements for the unique Burmester "feel-good sound"
- Sound optimization for the front and rear seats
- Noise compensation (VNC)
- Sound preset: surround function to generate virtual all-round sound
- Support for popular multi-channel formats such as Dolby Digital 5.1/DTS for example, for true surround sound (only in conjunction with COMAND Online)



## Gallery

101 – Black MB-Tex



114 – Espresso Brown/Black MB-Tex



# Gallery

234 – Saddle Brown Leather



225 – Silk Beige/Espresso Brown Leather





## Gallery

P87 – *designo* Black/Black Leather  
(Linden Wood Trim)



P87 – *designo* Black/Black Leather  
(Linden Wood Trim)





## Gallery

P62 – *designo* Platinum White/Black Leather  
(Natural Grain Black Ash Wood Trim in Center Console)



P62 – *designo* Platinum White/Black Leather  
(Natural Grain Black Ash Wood Trim in Center Console)



# Gallery

877 - Ambient Lighting



877 - Ambient Lighting



## Gallery

Standard OFF-ROAD Exterior (Front)



Standard OFF-ROAD Exterior (Rear)





# Gallery

Optional Sport Package Exterior (Front)



Optional Sport Package Exterior (Rear)



# Gallery

## Cargo Position



Load compartment with rear bench fully folded



## Gallery

234 – Leather Saddle Brown/Black (Left & center seat folded)



234 – Leather Saddle Brown/Black (Right seat folded)





# Gallery

AMG GLC43 (Front)



AMG GLC43 Exterior (Rear)



# Gallery

Standard Roof Spoiler



105 – Accessory Roof Spoiler







# AMG GLC43 Ordering Guide

## What's new: MY17 Overview

### Variants

- New AMG GLC 43

### Standard Equipment

- AMG-enhanced 9G-TRONIC transmission w/ shift paddles
- 3-stage ESP system
- AMG Sport Suspension based on AIR BODY CONTROL
- AMG Performance 4MATIC with 31% front/69% rear power distribution
- AMG DYNAMIC SELECT (ECO, Comfort, Sport, Sport+, Individual)
- Rearview Camera
- SIRIUSXM Satellite Radio
- Aluminum Trim

### Optional Equipment

- Touchpad only available with COMAND
- AMG Performance Seats

### AMG Exclusive Upholsteries

- Black MB-Tex/DINAMICA Upholstery with Red Stitching (641)
- Black Leather with Red Stitching (241)

### AMG Exclusive Trims

- Addition of AMG Carbon Fiber Trim (H73)



## What's new: 521 – AMG Night Package



Striking design features in black underscore the sporty, expressive character of the vehicle

The Night Package includes:

- ① Simulated front under guard in high-gloss black
- ② High-gloss black fins in the AMG front apron
- ③ Roof rails powder-coated in matte black
- ④ AMG rear apron with trim in high-gloss black
  - Exhaust tailpipes in black chrome



## What's new: AMG DYNAMIC SELECT

*Standard on the GLC43*



At a touch of the AMG DYNAMIC SELECT feature, drivers can choose between 5 different drive modes as desired. Parameters such as the engine, transmission, exhaust system, suspension and steering characteristics are adjusted according to the selected drive mode.

Choice of up to 5 different driving programs:

1. "Comfort" standard setting: well-balanced and fuel-efficient using the Auto Start/Stop function & early upshifts
2. "Eco" mode: for keeping fuel consumption as low as possible using the Auto Start/Stop function & very early upshifts
3. "Sport" mode: sportier driving with early downshifts and double-declutching when downshifting
4. "Sport+" mode: extremely sporty driving style thanks to acoustically emphasized throttle blips during downshifts as well as selective torque interventions on upshifts with cylinder suppression for optimal shift times, higher idling speed for faster starting off
5. "Individual" mode: individual parameters can be varied as required, using the Controller and the configuration menu in the head unit



# What's new: Exterior/Interior Dimensions

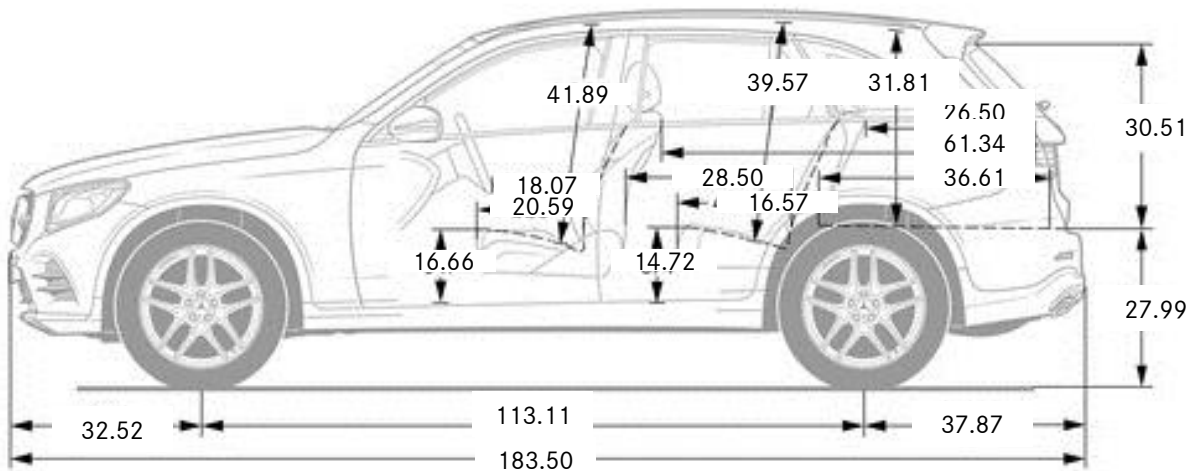
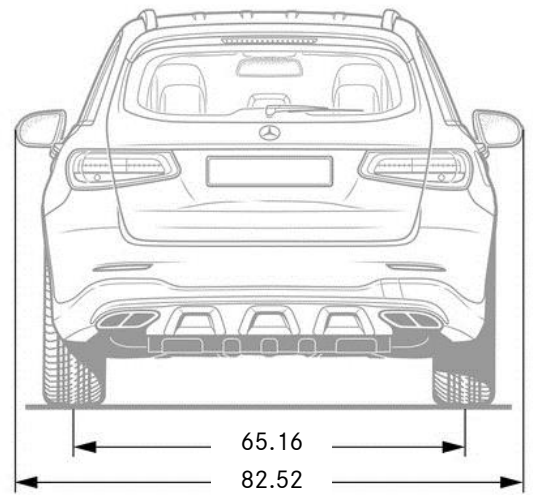
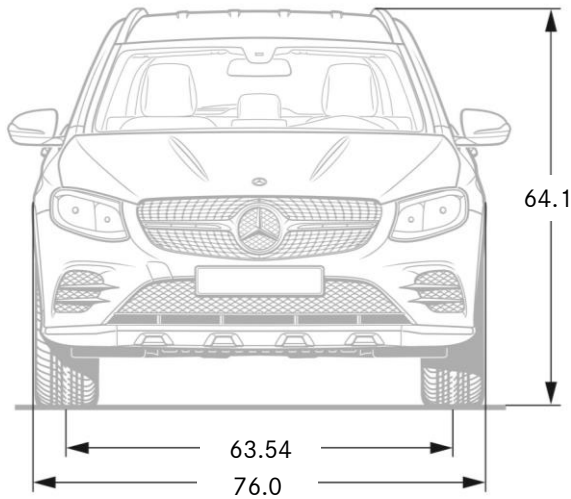

## Standard Equipment Highlights

### Performance/Handling

- AMG Enhanced 3.0L V6 Biturbo (362 hp, 384 lb-ft torque)
- AMG Sport Suspension based on Air Body Control
- AMG Enhanced 9G-TRONIC 9-speed Automatic Transmission
- AMG Performance 4MATIC
- AMG DYNAMIC SELECT
- 3-Stage ESP

### Comfort/Convenience

- KEYLESS-GO
- 20" AMG wheels
- AMG Interior/Exterior
- AMG Sport Steering Wheel with Paddle Shifters
- Heated Front Seats
- MB-Tex covered Dashboard
- Red Seat Belts
- Aluminum Trim
- Black MB-Tex/DINAMICA Upholstery w/ Red Accents
- Rearview Camera
- Media Interface
- GARMIN Pre-Wiring
- SiriusXM Satellite Radio
- 115V AC Power Outlet

### Safety/Security

- Collision Prev. Assist PLUS (CPA+)
- PRE-SAFE
- Crosswind Assist
- Blind Spot Assist



# Paints

## Non-metallic Paints



040  
Black



149  
Polar White

## Metallic Paints<sup>1</sup>



197  
Obsidian Black



775  
Iridium Silver



796  
Dakota Brown



890  
Lunar Blue



896  
Brilliant Blue



992  
Selenite Grey

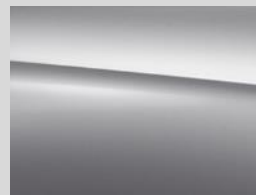

988  
Diamond Silver

## *designo* Metallic Paints



Metallic paint with high-quality effect pigments and exclusive color shades

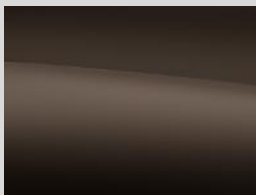

271  
Dakota Brown  
Magno<sup>2</sup>

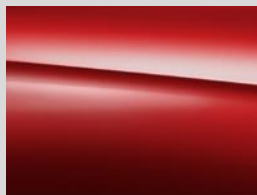

996  
Cardinal Red<sup>3</sup>



799  
Diamond White<sup>4</sup>

<sup>1</sup>Additional charges: \$720

<sup>2</sup>Additional charges: \$3,950

<sup>3</sup>Additional charges: \$1,080

<sup>4</sup>Additional charges: \$1,515



# Upholsteries

## AMG GLC 43

MB-Tex



641 Black MB-Tex w/  
DINAMICA and Red  
Stitching - *Standard*

Upholstery Code	641 Black MB-Tex/DINAMICA w/ Red Accents
Floor Mats	Black
Dashboard	Black
Seat Belts	Red
Steering Wheel	Black
Headliner	Black





# Upholsteries

## AMG GLC 43

Leather



221 Black



224 Espresso Brown/Black



225 Silk Beige/Esspresso Brown



234 Saddle Brown/Black



241 Black w/Red  
Stitching

Upholstery Code	221 Black Leather	224 Brown/Black Leather	225 Beige/Brown Leather	234 Brown/Black Leather	241 Black w/Red Accents
<b>Floor Mats</b>	Black	Espresso Brown	Espresso Brown	Black	Black
<b>Dashboard</b>	Black	Espresso Brown	Espresso Brown	Black	Black
<b>Seat Belts</b>	Black	Black	Silk Beige	Black	Red
<b>Steering Wheel</b>	Black	Espresso Brown	Espresso Brown	Black	Black
<b>Headliner</b>	Black	Black	Silk Beige	Black	Black

# Upholsteries

Optional



*designo*  
Exclusive Nappa Leather



P87 *designo*  
Black/Black  
**\$3,950**  
(requires P02 or P03)

P62 *designo*  
Platinum White/Black  
**\$3,950**  
(requires P02 or P03)

Upholstery Code	P87 Designo Black Nappa Leather	P62 Designo Platinum White/Black Nappa Leather
Floor Mats	Black	Black
Dashboard	Black	Black
Seat Belts	Silver	Silver
Steering Wheel	Black	Black
Headliner	Black	Black



# Trims

## H07 – Dark Brown Linden Wood



No-cost option  
**Limited Availability**

## H24 – Light Brown Linden Wood



No-cost option

## H73 – AMG Carbon Fiber

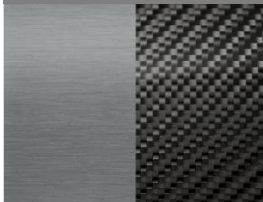

Optional  
 \$1,150

## 736 – Natural Grain Black Ash Wood



Optional  
 \$160  
**Limited Availability**

## 739 – Brushed Aluminum Door Trim - *Standard*



- Features High-Gloss Black center console **unless** *designo* Platinum White/Black Nappa leather package is selected (P62).
- When P62 is selected, the center console features Natural Grain Black Ash Wood trim.



# Wheels

AMG GLC 43

**Standard**



93R – AMG Multi-spoke w/ Black Accents  
R02/R66  
**20"**

**Optional**



92R – AMG Multi-spoke  
R02/R66  
**20"**  
\$0

**Optional**



650 – AMG Twin 5-spoke  
R01  
**21"**  
\$1,000



684 – AMG Twin 5-spoke w/ Black Accents  
R01  
**21"**  
\$1,000



## Option Packages

### P01 – Premium 1 Package

Standard

- 536 – SiriusXM® Satellite Radio
- 234 – Blind Spot Assist
- U80 – 115V AC power outlet
- 889 – KEYLESS-GO

### P02 – Premium 2 Package

\$2,350

***Requires Burmester Surround Sound System (810)***

- 531 – COMAND Navigation w/ Single Disc Player
- 502 – Navigation Map Updates for 3 Years
- 5 years Traffic and Weather Services (provided by SiriusXM®)
- 448 – Touchpad
- 877 – Ambient Lighting (Including Doorsills)
- 30P – Storage Package
  - Tensioning strap in the stowage compartment in the center console
  - Map pockets on the rear of the front seats
  - Net on the load compartment floor
  - Collapsible box under luggage compartment floor
  - Power release for rear backrests next to the rear seats, left and right

### P03 – Premium 3 Package

\$5,950

***Requires Burmester Surround Sound System (810)***

***Includes all Premium 2 Package features, plus:***

- 233 – DISTRONIC PLUS with Steering Assist
- 237 – Active Blind Spot Assist *replaces (234) Blind Spot Assist*
- 238 – Active Lane Keeping Assist
- 253 – PRE-SAFE Plus
- P21 – AIR BALANCE
- 640 – Active LED Headlamps
- 608 – Adaptive Highbeam Assist

## Option Packages (cont.)

### 521 – AMG Night Package

\$200

- P55 – Gloss black elements: front simulated underguard, front fins, rear diffuser trim, roof rails and exhaust tailpipes in black chrome
- Requires the choice of either wheel: 93R or 684

### 996 – Advanced Parking Assist Package

\$1,550

*Requires P02 or P03 Package*

- P44 – Parking Package w/ Surround View System
- P17 – Hands-free Package
  - KEYLESS-GO access and drive authorization system
  - Fully automatic luggage compartment door
  - HANDS-FREE ACCESS
  - Convenience opening and closing
  - Handle recess illumination
- 235 – PARKTRONIC w/ Active Parking Assist



## Standalone Options

Standalone Options		
2xx	Leather Upholstery <i>Includes Passenger Seat w/ Memory Function (242)</i>	\$1,900
313	Rear Door Roller Blinds	\$380
401	Heated and Ventilated Front Seats <i>Delayed Availability</i> <i>n/a with 641 and 241 upholsteries</i>	\$450
413	Panorama Roof <i>Standard Steel Roof</i>	\$1,480
443	Heated steering wheel <i>Not available with upholsteries 224 &amp; 225 upholsteries</i>	\$250
463	Head-Up Display	\$990
550	Trailer Hitch – Class II Hitch <i>not i.c.w. 996 Advanced Parking Assist Package</i>	\$575
632	LED Headlamps <i>Limited Availability</i> <i>Requires P02 package</i>	\$850
810	Burmester Surround Sound System	\$850
846	Brushed Aluminum Running Boards	\$670
872	Heated Rear Seats	\$620
P21	Air Balance	\$350
U17	Replace Red Seatbelts with Black <i>641 and 241 upholsteries only</i>	n/c



## Accessories/Special Orders

### Special Order Options (additional charge of \$250)

293	Rear Side Airbags	\$420
-----	-------------------	-------

### Accessories

03A	SD-Card for GARMIN® Map Pilot Navigation	\$625
00A	Illuminated Star <sup>1</sup>	\$550
068	Wheel Locks	\$140
070	Chrome Door Handles	\$100
105	Roof Spoiler <sup>2</sup>	\$350

<sup>1</sup> Not available with Premium 3 package

<sup>2</sup> Image provided in the Gallery section





# Visual Equipment Differentiation – Steering Wheels

## Sport Steering Wheel



- Standard.
- The 12 ergonomic control buttons on the leather multifunction sport steering wheel with flattened bottom section enable operation of the display menus in the instrument cluster and the Audio/COMAND display on the left. On the right, the driver can control the volume of audio devices, telephone and navigation system. Silver-colored aluminum shift paddles emphasize the sporty appeal.

## 443 – Heated Steering Wheel

**\$250**



- Optional.
- Not available with 224 & 225 upholstery options.

On cold days, heating of the steering wheel rim very rapidly ensures cozy temperatures of the grip area and thus also warm hands. The temperature oscillates around 95°F.



## Product Highlights: AMG Performance 4MATIC

Standard on AMG GLC43

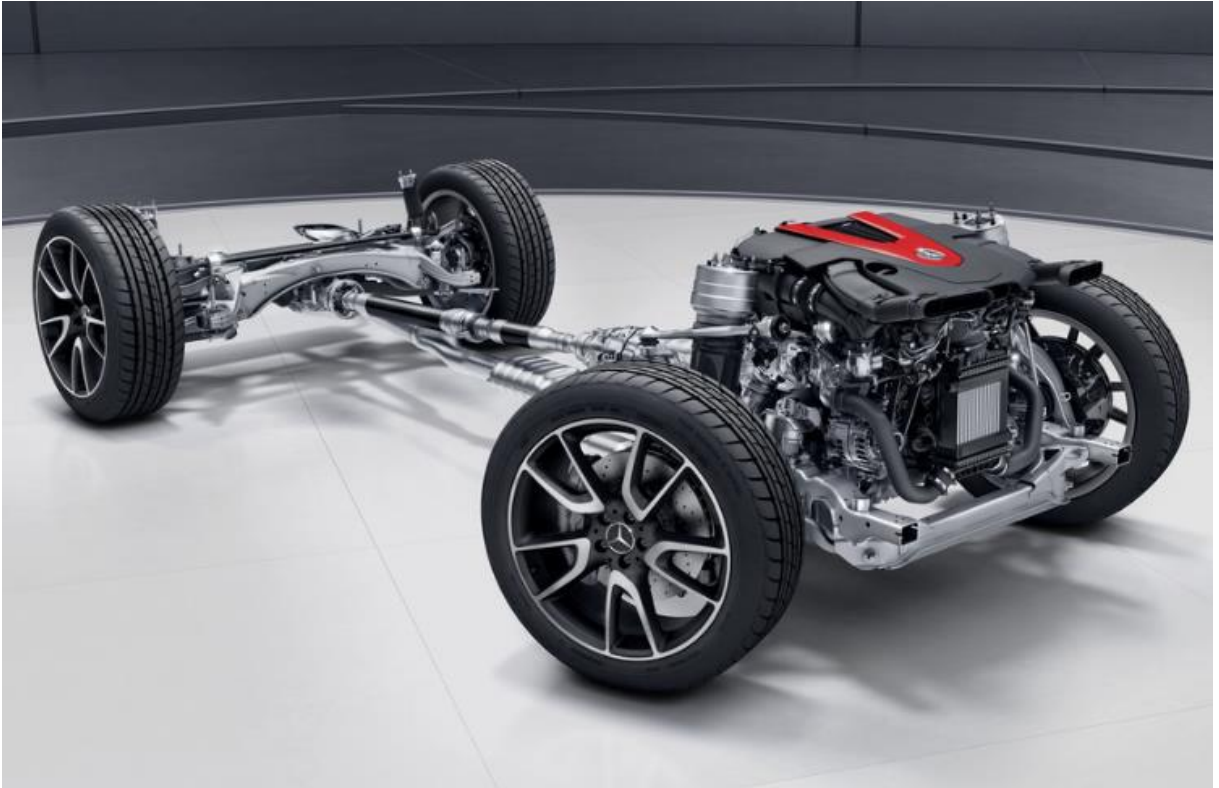

### **AMG Performance 4MATIC – more traction and driving pleasure in every weather**

The performance-oriented all-wheel drive developed by Mercedes-AMG combines optimum traction, hallmark AMG driving dynamics and maximum driving pleasure. This is ensured by the clear torque distribution to the rear. Unlike in the standard model, Mercedes-AMG distributes the engine torque in a ratio of 31% to the front axle and 69% to the rear axle. In addition, AMG 4MATIC all-wheel drive increases driving safety and traction on wet or wintry road surfaces.



## Product Highlights: **AMG Sport Suspension based on AIR BODY CONTROL**

Standard on AMG GLC43



### **AMG sport suspension based on AIR BODY CONTROL - better driving dynamics, more ride comfort**

- Multi-chamber air suspension combined with continuously adjustable damping to improve ride comfort and driving dynamics
- Sporty, AMG-specific spring/damper setup
- comfortable basic suspension with low natural frequency
- "Comfort", "Sport" and "Sport+" settings for a more comfortable, sporty or very sporty suspension setup
- Constant vehicle level irrespective of load, thanks to pneumatic all-round self-levelling suspension
- Suspension level can be raised for poor surfaces and is automatically lowered at high speeds



# Gallery

641 – MB-Tex/DINAMICA with Red Stitching



241 – Leather Black with Red Stitching





# Gallery

Standard Roof Spoiler



105 – Accessory Roof Spoiler

