



Mercedes Benz W223 Steering Wheel Retrofit Adapter

Installation Guide

Contents

Warning	3
Preface	4
Audience	4
Pre Installation Skills	4
Facelift Block Diagram	5
Retrofit Adapter Connection points and indication	6
New Steering Wheel connection points	7
Facelift Wiring Diagram for clock spring connector (step 1)	8
Facelift Wiring Diagram for clock spring connector (step 2)	9
Before coding	10
Coding procedure	10
Package list	10
Contacts	11

WARNING

This device is designed solely for use by properly trained and qualified automotive electronics experts, who are familiar with the dangers related to handling electrical equipment and systems. This manual intends to serve as a guide in the installation of adapter, failure to follow these instruction could result in a hazardous condition, destruction of car equipment and the retrofit adapter.

**DISCONNECT ANY CHARGING EQUIPMENT BEFORE
INSTALLATION AND CODING:
CAR BATTERY CHARGER, NOTEBOOK CHARGER, ETC.**

There are NO user serviceable parts contained in the retrofit adapter. Unscrewing or opening your adapter will render your warranty void. If your retrofit adapter require repair, please contact us directly and we will assist you.

The manufacturer is not legally responsible for any equipment damage or personnel injury caused by incorrect installation by unqualified technicians.



Preface

This document will help you install the Mercedes Benz W223 Steering Wheel Retrofit adapter for all Mercedes Benz cars from 2011 till 2020 model year.



**Steering Wheel
before facelift**



**Steering Wheel
after facelift**

Audience

Mercedes Benz W223 Steering Wheel Retrofit Adapter for install facelift W223 steering wheel on: W167, W190, W213, W238, W463 from the 2019 model year; W222, W217 from 2017 model year and W205, W253 from 2017 model year.

The adapter supports the new operating logic of adaptive cruise control DISTRONIC. W223 steering wheels are supplied without vibration motor. For some car models adapter emulates missing vibration motor. This is necessary for the correct functioning of the driving assistant systems.

Pre Installation Skills

This document expects that you are familiar with automotive electronics, knowledge and experience in that field. High automotive diagnostic skills are welcome.

Facelift Block Diagram

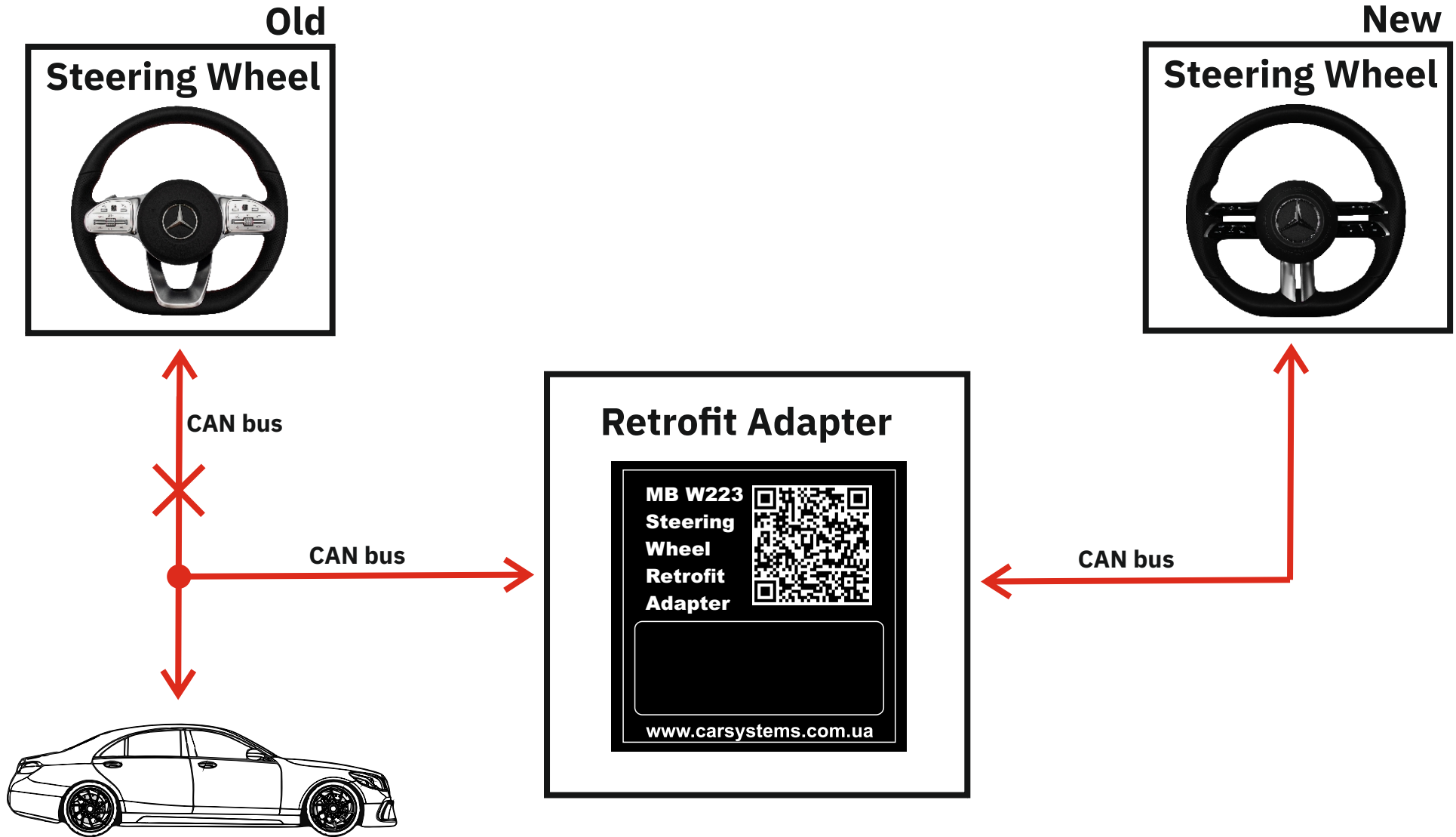

Retrofit Adapter connection points and indication

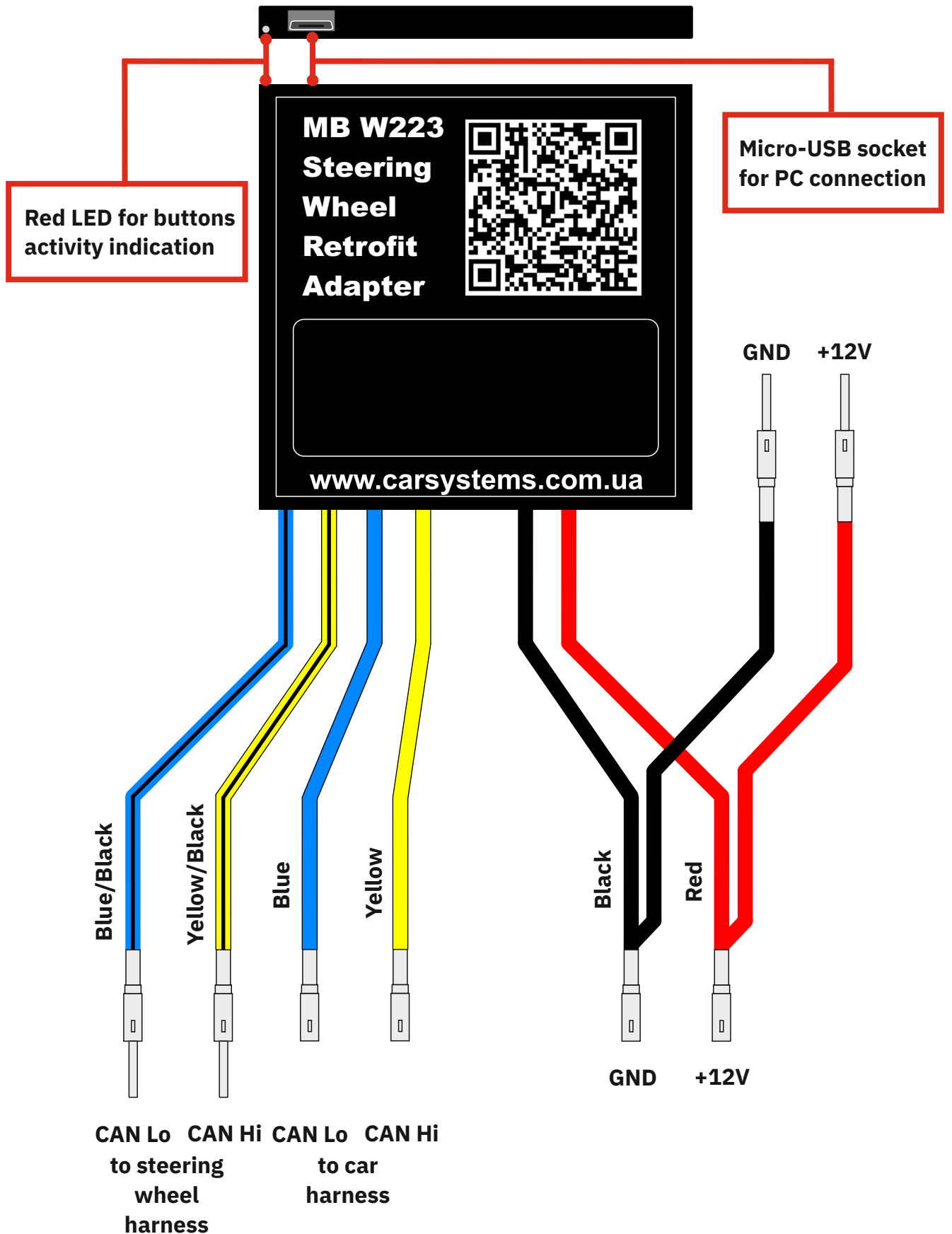

New Steering Wheel connection points

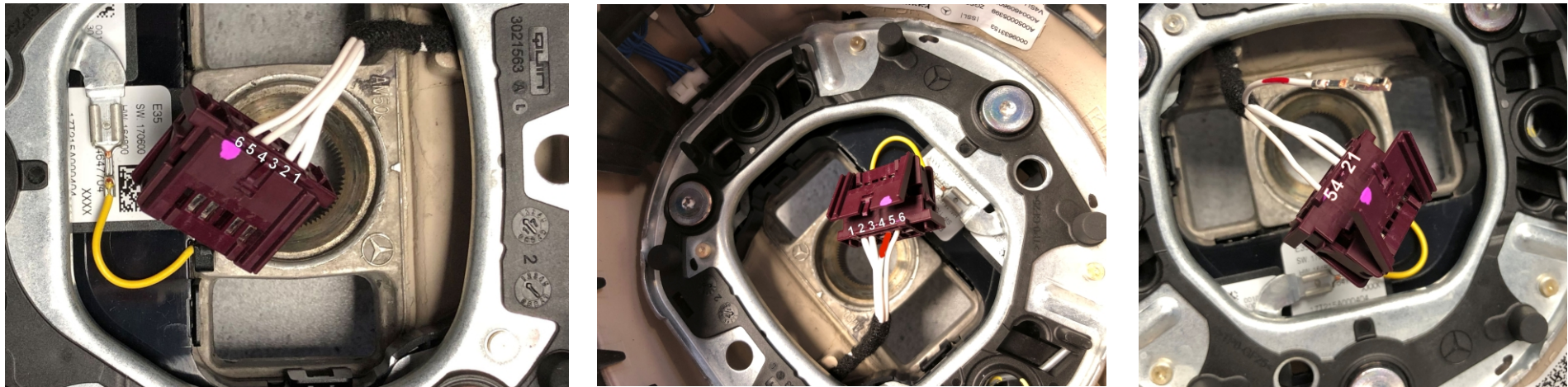

New Steering Wheel Connector	Pin assignment	Notation
Pin 1	+12V	Mark and remove from the connector housing for retrofitting
Pin 2	GND	Remove from the connector housing for retrofitting
Pin 3	N/C	Not connected
Pin 4	CAN Hi	Mark and remove from the connector housing for retrofitting
Pin 5	CAN Lo	Remove from the connector housing for retrofitting
Pin 6	N/C	Not connected

Facelift Wiring Diagram for clock spring connector (step 1)

New harness (Steering Wheel side)

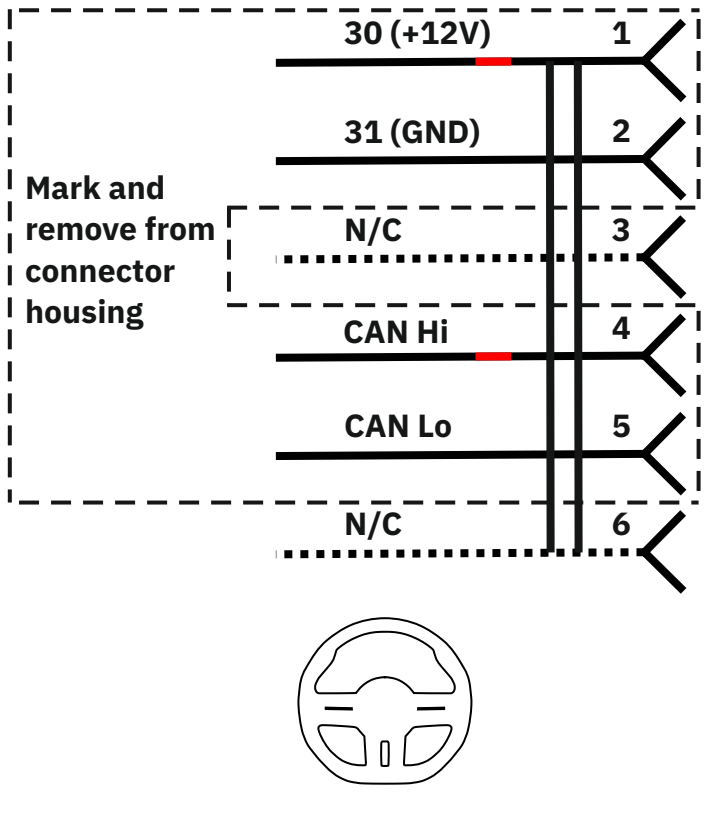

Insert into new steering wheel connector housing

W222/W217 LCI harness (car side)

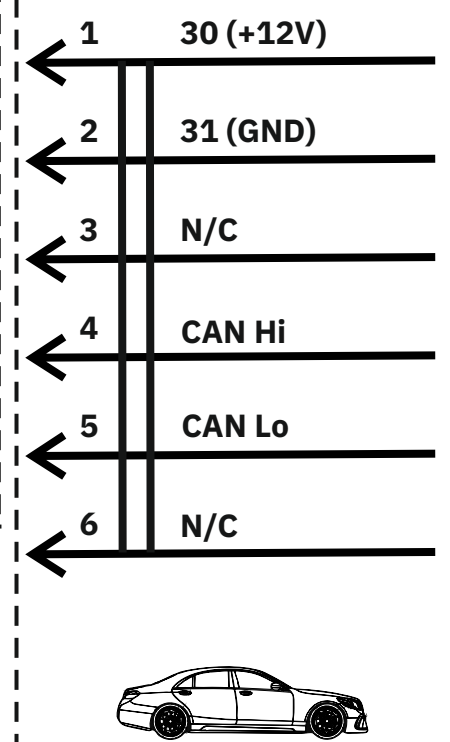

MB W223 Steering Wheel Retrofit Adapter

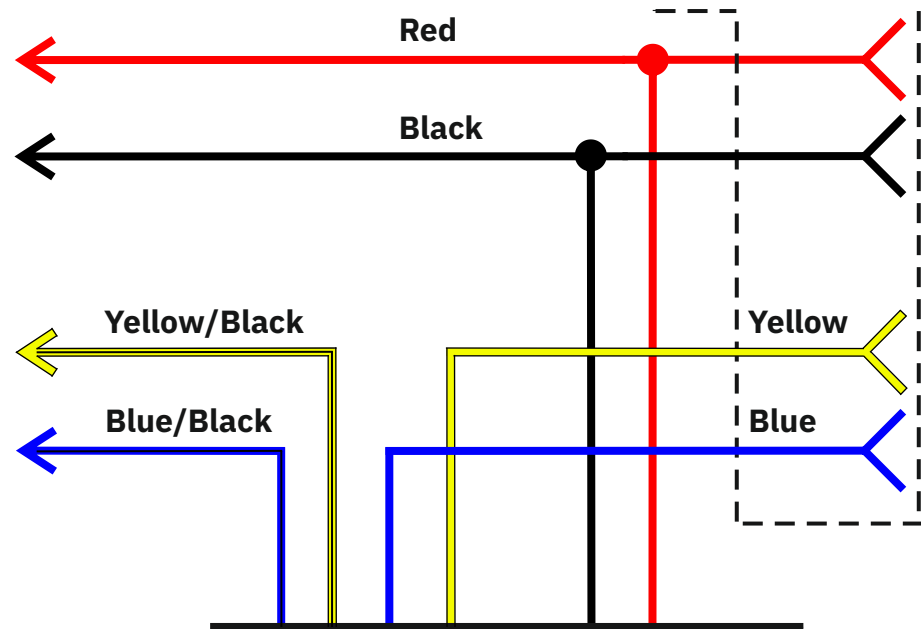

Facelift Wiring Diagram for clock spring connector (step 2)

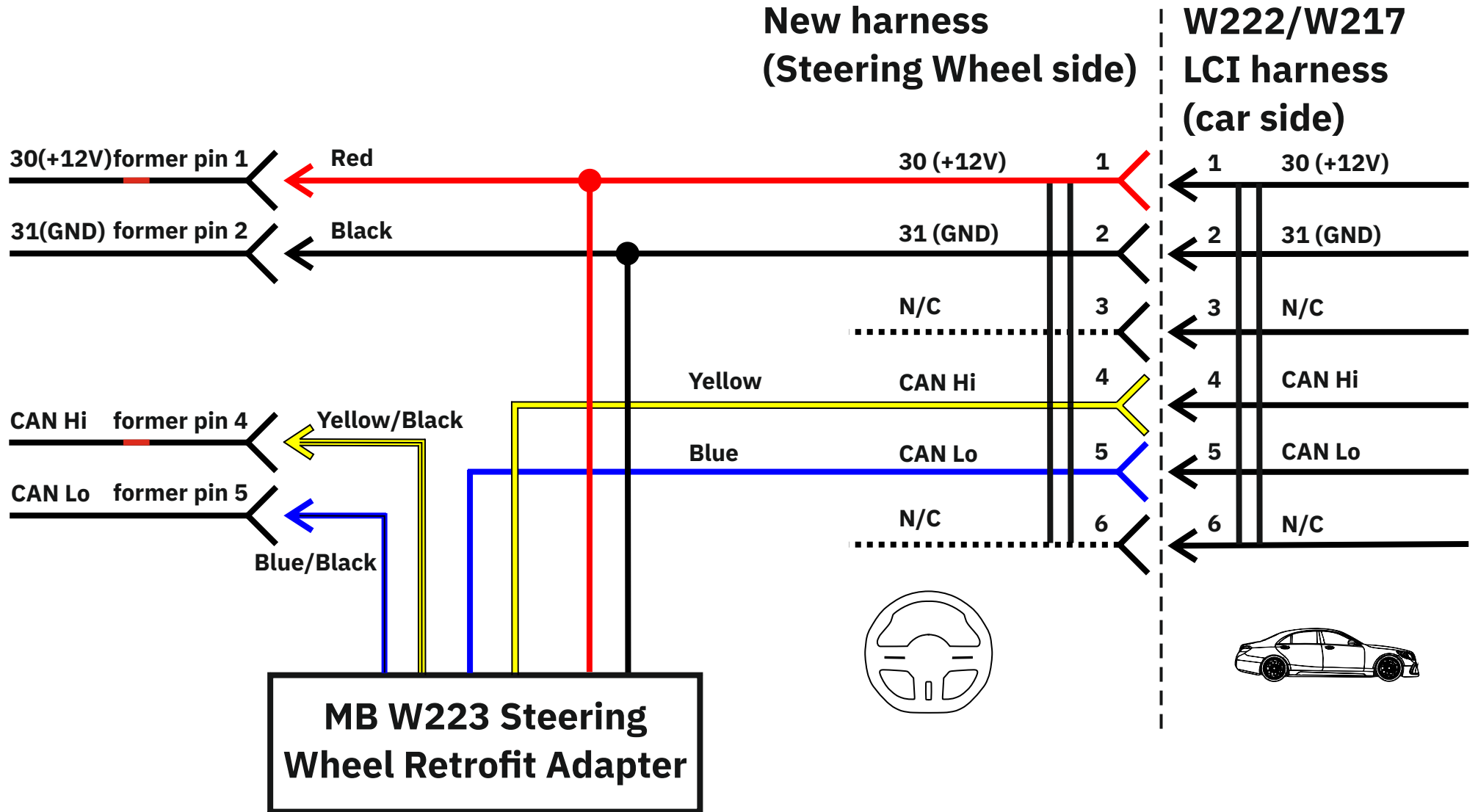

Before coding

Before AirBag installation, testing is required.

The red LED inside adapter is used for diagnostic purposes. LED flash indicates any button pressing on the steering wheel.

You should check each button on the steering wheel and the corresponding reaction of the car's systems.

Coding procedure

In most cases, the adapter does not need coding. With proper installation, no problems arise.

Package list

- 1. Mercedes Benz W223 Steering Wheel retrofit adapter - 1pcs**

Contacts



Mail: support@carsystems.com.ua



Telephone: [+38 \(096\) 809-00-11](tel:+380968090011)



Skype: [carsystems.support](https://www.skype.com/add?contact=carsystems.support)



Viber: [+38 \(096\) 809-00-11](tel:+380968090011)



Telegram: [@CarSystems_Support](https://www.telegram.com/add?contact=@CarSystems_Support)

We provide technical support during our working hours:

**Monday to Friday (except public holidays),
from 10:00 to 19:00 (UTC+2:00).**

Due to the increasing amount of unsolicited emails we tightened anti-spam. If your letter has not been delivered, please contact us via Skype or through the inquiry form in our website carsystems.com.ua

