

**Model all (4xWD, CAR, Light transporter)**

The external differentiation features between these batteries and conventional batteries are:

- Black housing
- VRLA battery or AGM battery labeling
- Non-detachable covers (A)

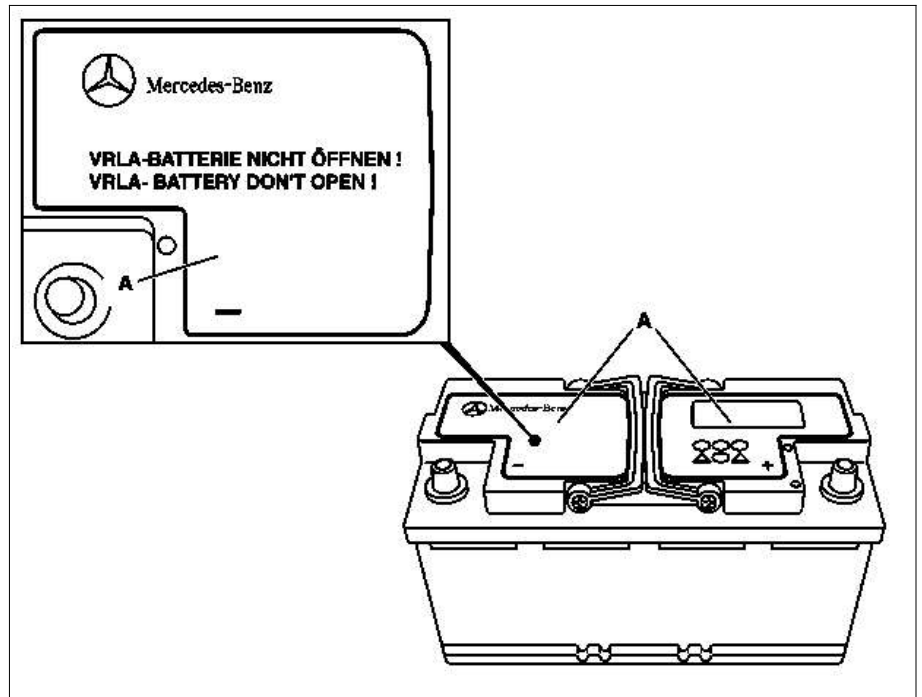

P54.10-2098-06

**Absorbent glass mat (AGM) battery structure**

Instead of the acid in a conventional battery, a conductive fabric (V) is used.

Special properties:

- High cycle strength (long service life)
- Improved cold starting characteristics
- No escaping acid if housing damaged
- Improved deep-discharge resistance
- Absolutely maintenance-free

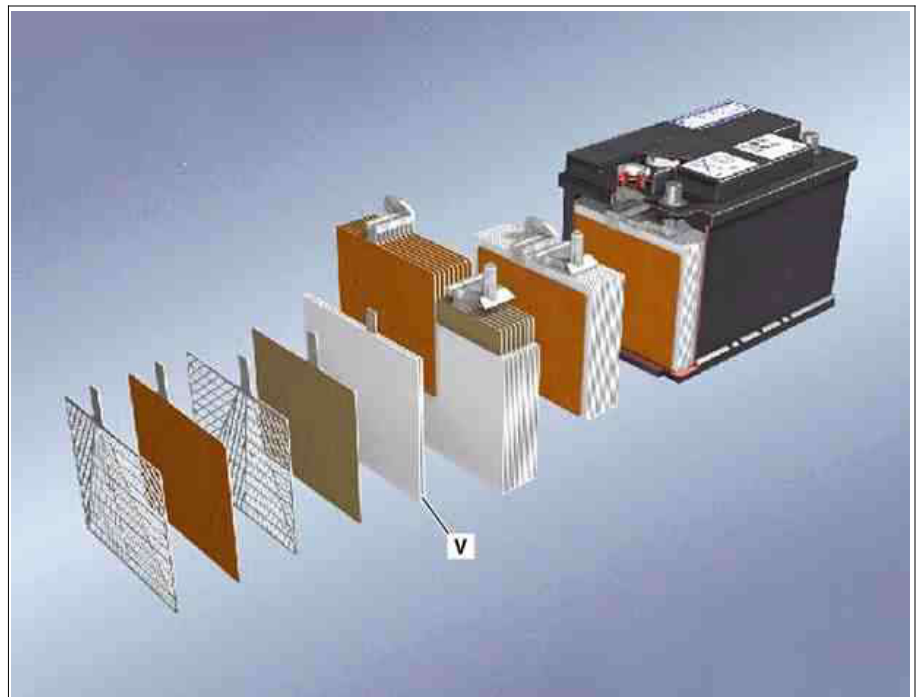

P54.10-2099-76

**Differentiating characteristics to conventional batteries**

- No stop plugs
- No acid level markings

- No externally vented stop plugs
- Information plate on the battery

**i** If the battery is replaced, the vent line must be connected with an elbow fitting to one side of the battery and the stop plugs on the other side of the battery must be pressed in.