



Overview of new products/features/
modifications: Introduction of new
inline engine M 256

Mercedes-Benz



SN00.00-P-0061A	Overview of new products/features/modifications: Introduction of new inline engine M 256	03.08.2017
-----------------	---	------------

Engine **256 in model 222**

Engine 256 - the 6-cylinder spark-ignition inline engine (M 256) with 48 volt electrification

The M 256 as a spark-ignition engine, represents the start a new in-line engine family from Mercedes-Benz and now replaces its successful predecessor, the V6 engine 276.

The 48 volt electrification that was also part of the engine design process right from the start along with a series of further innovative measures, means that despite the ambitious performance goals involved, it was also possible to achieve significant reductions in consumption levels.

The belt-less engine with integrated starter-alternator (ISA), exhibits an outstanding response characteristic across the entire rpm range. This is achieved through the use of an electric additional compressor, high-performance exhaust

gas turbocharger and the boost effect made possible by the integrated starter alternator.

Along with the implementation of 48 volt components, the range of technology in the innovative powerplant includes further modules such as a variable-control oil circuit, intelligent heat management, a gasoline particulate filter and measures for reducing friction.

The result is a carbon dioxide (CO₂) reduction of almost 20 % coupled with an output increase of more than 15 % compared with the predecessor, the V6 engine 276, a 6-cylinder engine, one that compares favorably with four-cylinder engine regions in terms of consumption while the output can hold its own when up against with 8-cylinder engines.

Front left view of engine



P01.10-3423-05

View of engine from rear left



P01.10-3424-05

Brief description

New features :

- Off-set engine (i.e. the cylinder bores opposite the crankshaft axis are offset towards the cold side)
- Friction-optimized engine
- Timing assembly on transmission side
- Crankcase as well as the cylinder head made of aluminum - this is alloyed with zircon, which dissipates the heat even more efficiently.
- Cylinder barrels lined in NANOSLIDE® technology (iron-carbon)
- Engineered for a maximum combustion chamber pressure of 120 bar with sufficient reserves for further output increases during its service life
- Engine carrier made of plastic
- Modular, future-compliant exhaust system near-engine mounted
- Integrated starter alternator (ISA)

- Electric additional compressor
- Belt-less engine
- Electric coolant pump
- Electric refrigerant compressor

Tried and tested:

- Four valves per cylinder
- CAMTRONIC on the inlet side
- Two camshaft adjusters for the inlet and exhaust sides ensure optimized development of engine torque and improved exhaust characteristics
- Low-noise chain-drive system with silent chain
- Compact vane-type oil pump with demand-oriented flow control
- 3rd generation gasoline direct injection with 200 bar fuel pressure, piezo injectors and spray guided multiple injection
- Multiple-spark ignition system for optimum ignition and combustion (multispark ignition)

Location of M 256

1	Intake camshaft with CAMTRONIC
2	Piezo injectors
3	Cooling duct piston
5	Belt-less engine
6	Crankcase with NANOSLIDE® barrel
7	Near-engine mounted catalytic converter
A9/5	Electric refrigerant compressor
M75/11	Electric coolant pump

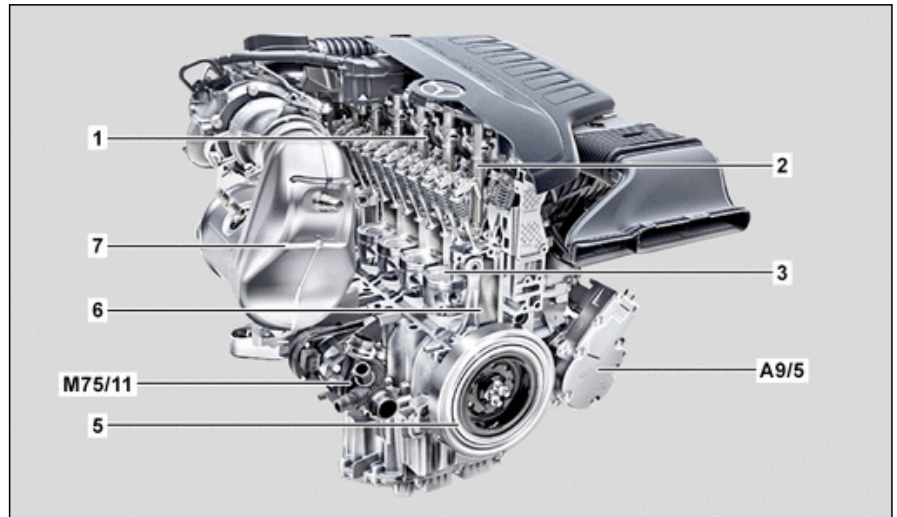

P01.00-3724-75

Basic engine

A design criterion for many essential technology modules in the long block engine is CO₂ efficiency. At the heart of this was the reduction in friction, further optimization of the oil circuit through a "SplitOiling concept", combustion optimizations and the use of CAMTRONIC with advanced intake-valve closing.

Friction optimization

Numerous detailed measures were implemented with the goal of further reducing friction losses caused by moving parts in the engine. This includes:

- Inline engine with 12 mm offset
- Discontinuation of belt drive through systematic electrification of all ancillaries through the use of an integrated starter alternator (ISA)
- Low-friction, shorter chain drive
- Crankshaft bearing with connecting rod oil supply for two crank pins each consisting of a crescent supply groove in the basic bearing
- Piston with optimized piston rings
- Cylinder coating through latest generation of NANOSLIDE® technology
- Oil circuit optimization through pressure controlled dual-circuit system and reduction in oil flow rate

- Use of low-viscosity oil

Crankcase and crank assembly

The crankcase is made from die-cast aluminum. The cylinder contact surface is machined with a Mercedes-Benz patented twin-wire-arc spraying method.

The NANOSLIDE® technology developed in-house significantly reduces friction losses compared with cast iron bushings.

The twin-wire-arc spraying method sprays a layer of iron onto the pre-worked crankcase. The subsequent precision machining creates a dead-smooth, friction-optimized barrel, that is highly wear resistant and so thin that an optimum transmission of heat to the coolant jacket is assured.

The crankshaft and connecting rod are made of forged steel.

The higher specific output increases the thermal and mechanical loads acting on the piston crown. To reduce these loads and to lower the temperature of the piston crown, the pistons are equipped with cooling ducts. The piston crown temperature achieved with the aid of piston cooling helps to ensure stable combustion while also lowering the level of in-engine emissions. The piston cooling is integrated into the oil circuit's thermal management.

Location

- 1 Cooling duct
- 2 Piston
- 3 Friction reduced piston rings
- 4 Piston pin

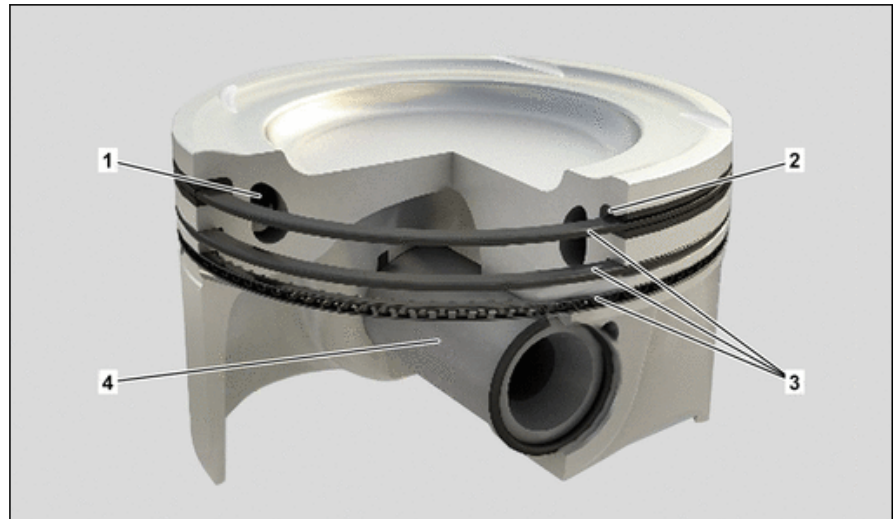

P03.10-2184-75

Oil circuit - "SplitOiling concept"

An important development objective for the oil circuit was the high adjustment performance of the camshafts. This serves primarily to reduce emissions and realize a higher driving dynamics standard.

The goal then is to supply the hydraulic camshaft positioner with the required level of oil pressure, so that an adjustment at the required speed is already possible at idle speed.

In a 6-cylinder inline engine, the inhibitory average camshaft load moments generated in the main operating range, place high demands on the oil pressure level.

This is where the so-called "SplitOiling concept" is used for the first time. This refers to an oil circuit, that permanently provides a stable, hydraulically-controlled high pressure for the camshaft positioner, along with a map-controlled low pressure for the remaining lubrication points, using only one variable volumetric flow vane-type oil pump to do so.

The hardware for the low-pressure management system is integrated into the oil filter module to save space. A solenoid valve is used here to actuate a pilot-controlled

piston, which opens up the necessary cross sectional area between the high pressure and the low pressure. A pressure and temperature sensor in the main oil gallery closes off the closed-loop control circuit.

The new system also presented a challenge in terms of the control software required. This was fundamentally adapted to the "SplitOiling concept" and expanded with the aid of further features to form a part of the intelligent thermal management. This also includes, the delivery-on-demand piston cooling, that was realized without the need for additional ducts and electrical actuators.

The adapted consumer supply on the low-pressure side ensures the lowest-possible oil flow rate while at the same time it is also part of the thermal management. During warm-up, particulate emissions can therefore be significantly reduced.

The fast build up of oil pressure when the engine is started, a high-pressure level available from idle speed onwards, and the advanced adjustment readiness of the camshaft positioner enable the required contribution in terms of responsiveness, issues and consumption to be reached.

Oil circuit - "SplitOiling concept"

- 1 Oil module
- 2 Heat exchanger
- 3 Return spring
- 4 Control plunger
- 6 Oil filter cartridge
- Y130 Engine oil pump valve
- A High pressure
- B Low pressure
- C Uncontrolled oil pressure

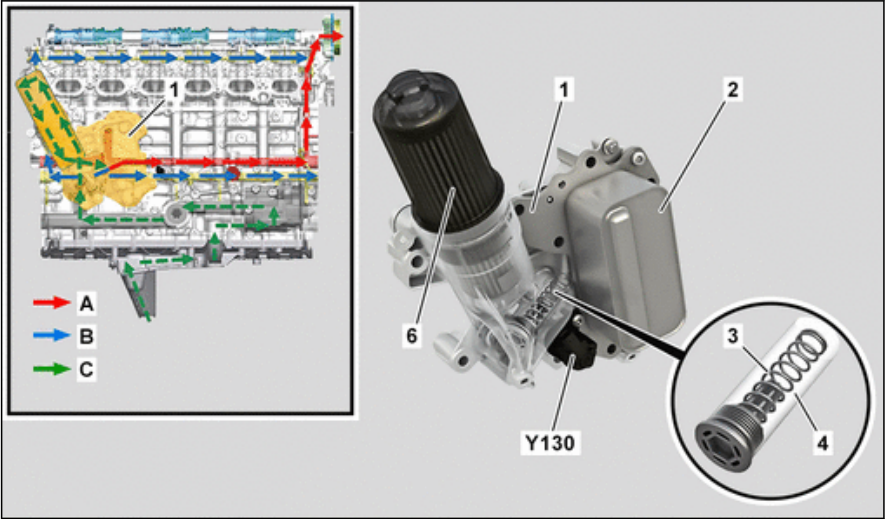

P18.00-2441-75

Engine top front view

- B4/4 Purging pressure sensor
- B11/4 Coolant temperature sensor
- M75/11 Electric coolant pump
- N3/10 ME-SFI [ME] control unit
- R48 Coolant thermostat heating element
- Y58/1 Purge control valve

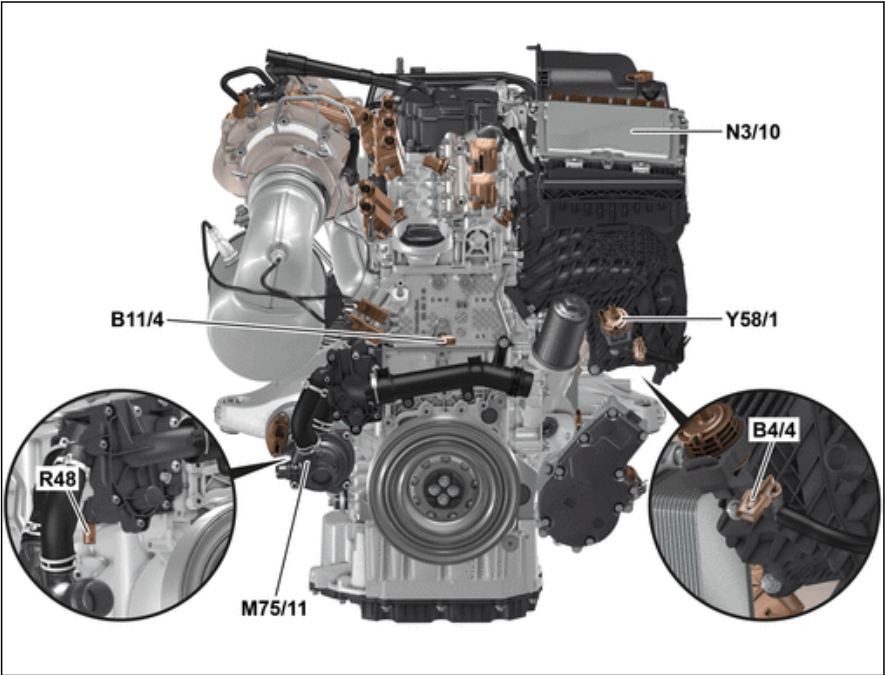

P01.10-3336-76

View of engine from left

- 19 Fuel system high pressure pump
- A16/1 Knock sensor 1
- A16/2 Knock sensor 2
- B70 Crankshaft Hall sensor
- B149/1 Engine oil pressure and temperature sensor
- Y94 Quantity control valve
- Y130 Engine oil pump valve

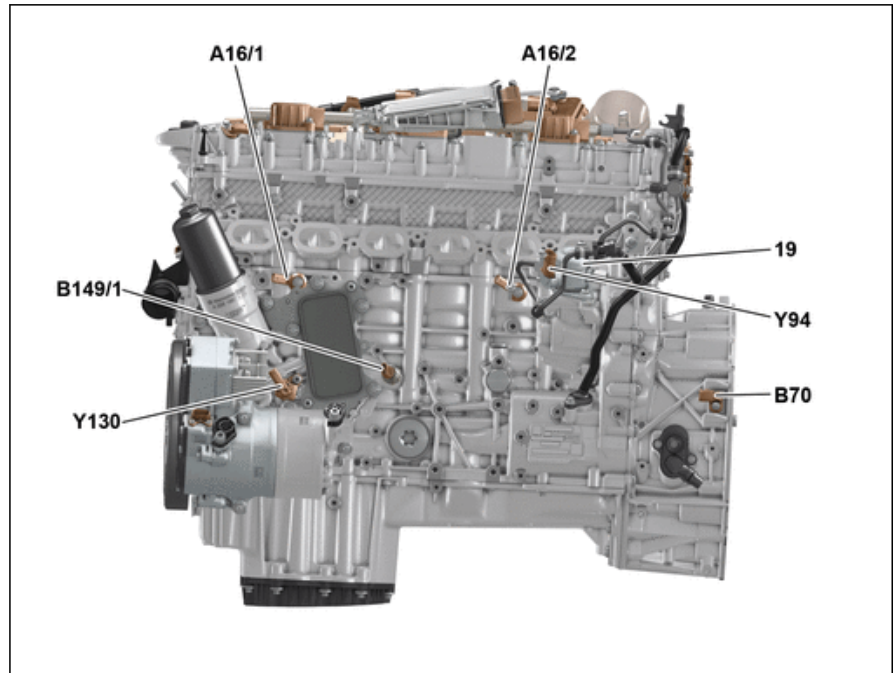

P01.10-3340-76

View of engine from right

- 25 Coolant thermostat
- M75/11 Electric coolant pump

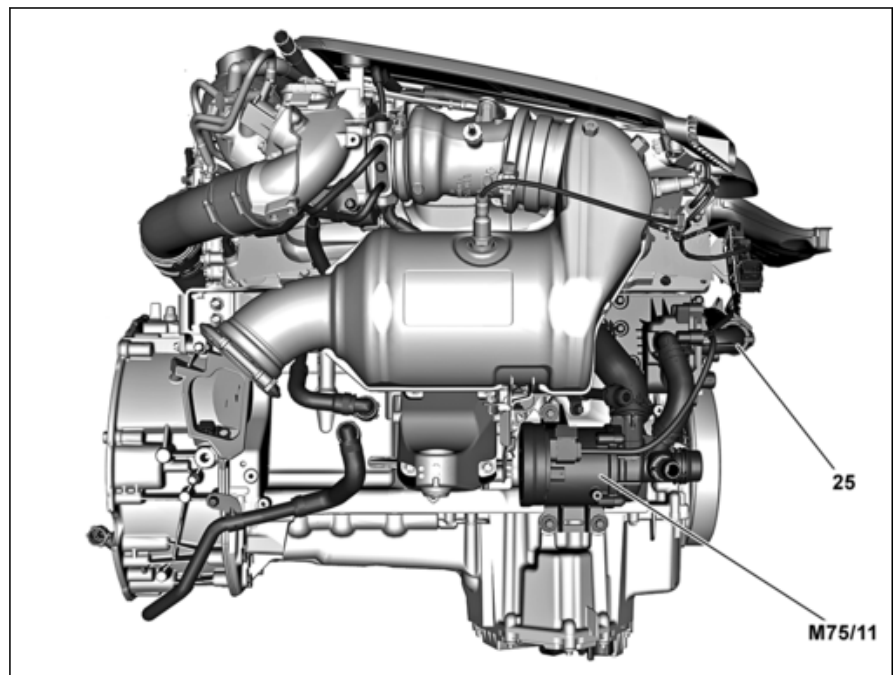

P01.10-3413-06

Cylinder head and combustion

The high power-to-swept-volume ratio of 106.7 kW/liter with compact design (cylinder-bore spacing 90 mm, bore 83 mm diameter) results in a high thermal load in the cylinder head.

A charge air cooler is integrated to optimize the heat balance, which despite the high degree of supercharging involved achieves excellent cooling of the compressed air. In addition to this, the charge air cooler also excels on account of its outstanding equal proportioning with a maximum difference of 5 K across the individual cylinders.

The installation of special exhaust valves also enabled the thermal load to be reduced. For the first time, sodium cooled exhaust valve has been used as hollow flat-seat valves, that excel on account of their significantly improved level of heat dissipation compared with the previous hollow

valves with a sodium filling in the stem. Smaller exhaust valves and a spark plug with higher thermal conductivity along with a smaller diameter (thread M10) enable better cooling to be achieved in the head, thereby reducing the tendency to knock.

Hollow flat-seat valve

- 1 *Hollow-stem valve*
- 2 *Hollow flat-seat valve (new with M 256)*



P05.30-2198-73

View of the engine from the rear

- A79 *Integrated starter generator*
- B28/17 *Pressure and temperature sensor downstream of exhaust gas turbocharger*
- B28/26 *Pressure and temperature sensor upstream of throttle valve*
- Y49/1 *Intake camshaft solenoid*
- Y49/2 *Exhaust camshaft solenoid*

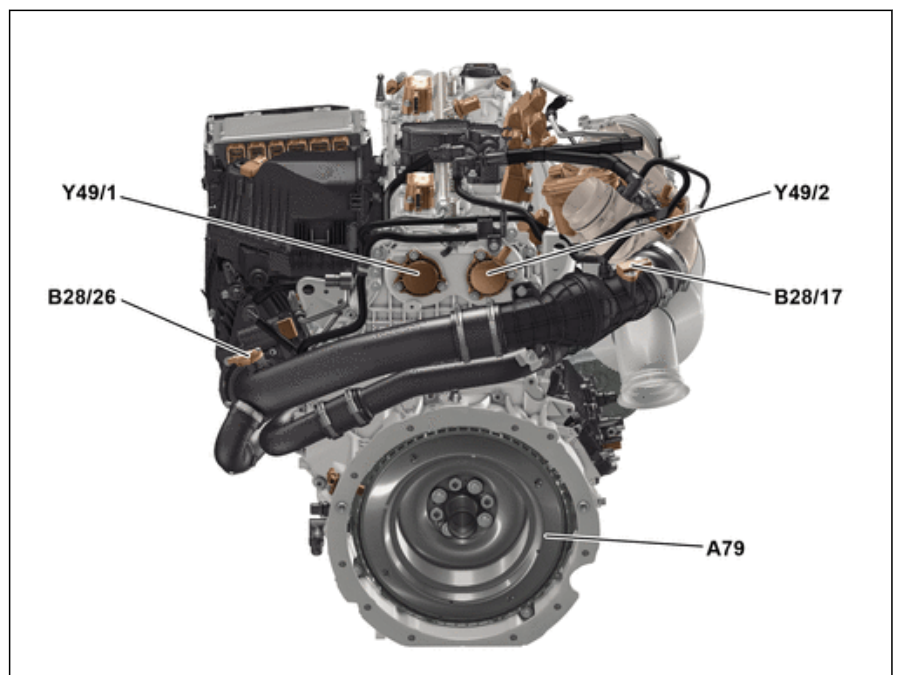

P01.10-3341-76

Valve train and CAMTRONIC

To achieve more economical timing, the adjustment range for the intake camshaft has been increased to a 70° crank angle (CKA).

Apart from this, the M 256 is also equipped with the Mercedes-Benz CAMTRONIC - i.e. variable engine timing, that makes two-stage stroke change-over on the inlet side possible.

The combination of CAMTRONIC and variable camshaft positioner with large adjustment range, enables a significant reduction in charge change losses in the lower load range to be achieved, both for a large valve lift through an Atkinson timing strategy, as well as for a small valve lift.

Operation at a small valve lift requires combustion-stabilizing measures. To allow for the adverse flame development conditions caused by the significantly reduced charge movement and the lower mixture temperatures at the ignition timing, the fuel is introduced through several partial injections into the combustion chamber, and flame development supported, if necessary through multi-spark ignition.

An asymmetric cam profile was also designed to further stabilize combustion through increased charge movement. The resulting swirl overlies the fuel/air mixture that is still in motion and by doing so it ensures more stable engine running at the lowest possible loads.

View of the engine from above

B4/25	Fuel pressure and temperature sensor
B6/15	Intake camshaft Hall sensor
B6/16	Exhaust camshaft Hall sensor
B28/11	Pressure sensor downstream of air filter
G3/1	Oxygen sensor downstream of catalytic converter
G3/2	Oxygen sensor upstream of catalytic converter
M16/7	Boost pressure control flap actuator
Y49/19	Cylinder 1 and 2 intake CAMTRONIC actuator
Y49/20	Cylinder 3 and 4 intake CAMTRONIC actuator
Y49/21	Cylinder 5 and 6 intake CAMTRONIC actuator
Y101	Divert air switchover valve

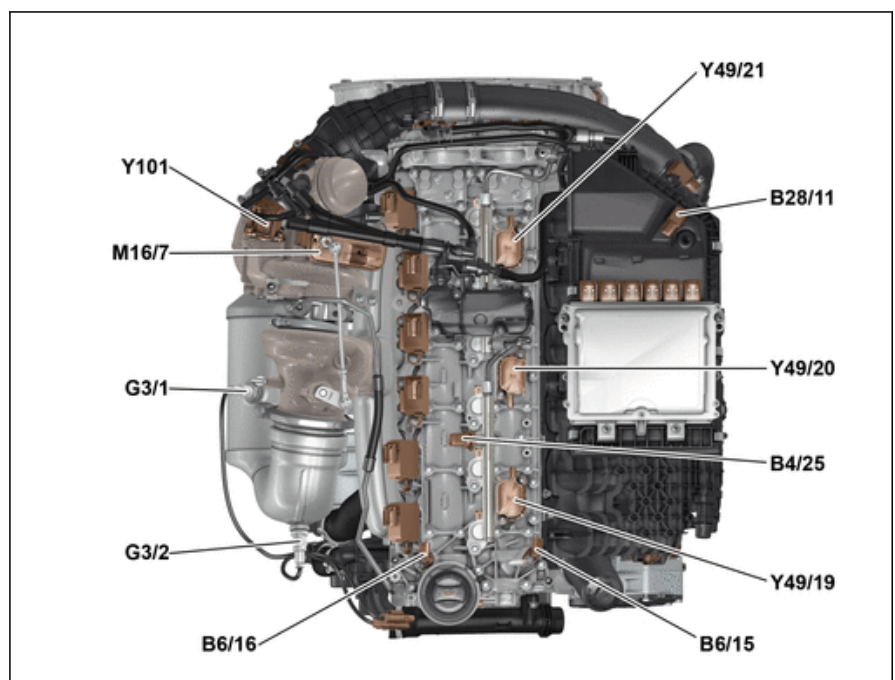

P01.10-3338-76

Function sequence for CAMTRONIC valve lift adjustment

With the CAMTRONIC valve lift adjustment, a map-controlled switchover between a low-lift and high-lift cam profile occurs for the intake valves in the intake camshaft.

Basic input factors are the engine speed, load and temperature. In the partial-load range, the intake valves are actuated with the low-lift cam profile. These do not therefore open as far and they close earlier. The short

opening period in combination with a wide-opened throttle valve leads to dethrottling in the partial-load range, while the lower valve lift reduces friction power. Both contribute to greater fuel economy. The switchover depends on the driver's load request.

Changeover is carried out by the following components:

- Cylinder 1 and 2 intake CAMTRONIC actuator
- Cylinder 3 and 4 intake CAMTRONIC actuator

• Cylinder 5 and 6 intake CAMTRONIC actuator

The actuators are actuated by the ME-SFI [ME] control unit with a pulse width modulated signal.

The intake camshaft consists of the following components: 6 machine-cut cam pieces are mounted onto the carrier shaft. Each cam piece controls the intake valves of one cylinder. The CAMTRONIC actuators each actuate 2 cam pieces simultaneously.

The cams themselves have the form of a double cam with two curved surfaces for each valve. If the steeper cam half is activated, the valve lift is increased and the valves remain open for longer. If the flatter half of the cam is switched to, the valve lift is shortened and the valves close sooner.

If the engine speed increases or the load request is increased, the cam pieces on the intake camshaft are switched to the high-lift cam profile.

To do this, a coil in the corresponding actuator is energized, and a tappet moves in a corresponding curved track on the cam piece. With the rotation of the camshaft and the design of the curved track, the cam pieces are moved axially and the high-lift cam profile acts on the intake valves. An incline in the curved track then results in the tappet being returned to the starting position.

To reset the camshaft to the low lift, a second tappet moves in the adjacent curved track and the reset correspondingly takes place.

The position determination of the tappets is realized via an integrated Hall sensor in the actuator.

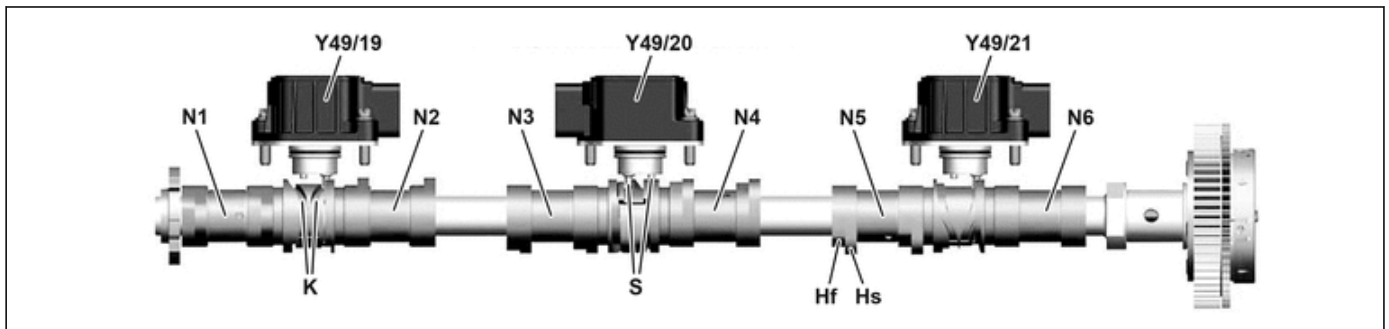

P05.20-2453-07

View of intake camshaft from left

Hf	Flatter half of cam	N5	Cam piece cylinder 5
Hs	Steeper half of cam	N6	Cam piece cylinder 6
K	Curved tracks	S	Tappet
N1	Cam piece cylinder 1	Y49/19	Cylinder 1 and 2 intake CAMTRONIC actuator
N2	Cam piece cylinder 2	Y49/20	Cylinder 3 and 4 intake CAMTRONIC actuator
N3	Cam piece cylinder 3	Y49/21	Cylinder 5 and 6 intake CAMTRONIC actuator
N4	Cam piece cylinder 4		

View of the engine from above

- T1/1 Cylinder 1 ignition coil
- T1/2 Cylinder 2 ignition coil
- T1/3 Cylinder 3 ignition coil
- T1/4 Cylinder 4 ignition coil
- T1/5 Cylinder 5 ignition coil
- T1/6 Cylinder 6 ignition coil
- Y76/1 Cylinder 1 fuel injector
- Y76/2 Cylinder 2 fuel injector
- Y76/3 Cylinder 3 fuel injector
- Y76/4 Cylinder 4 fuel injector
- Y76/5 Cylinder 5 fuel injector
- Y76/6 Cylinder 6 fuel injector

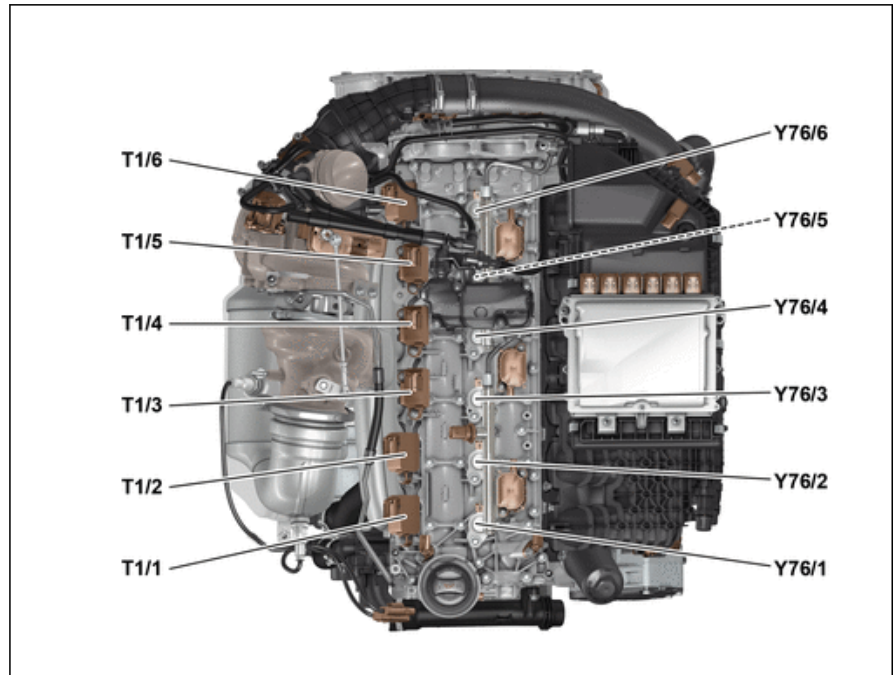

P01.10-3337-76

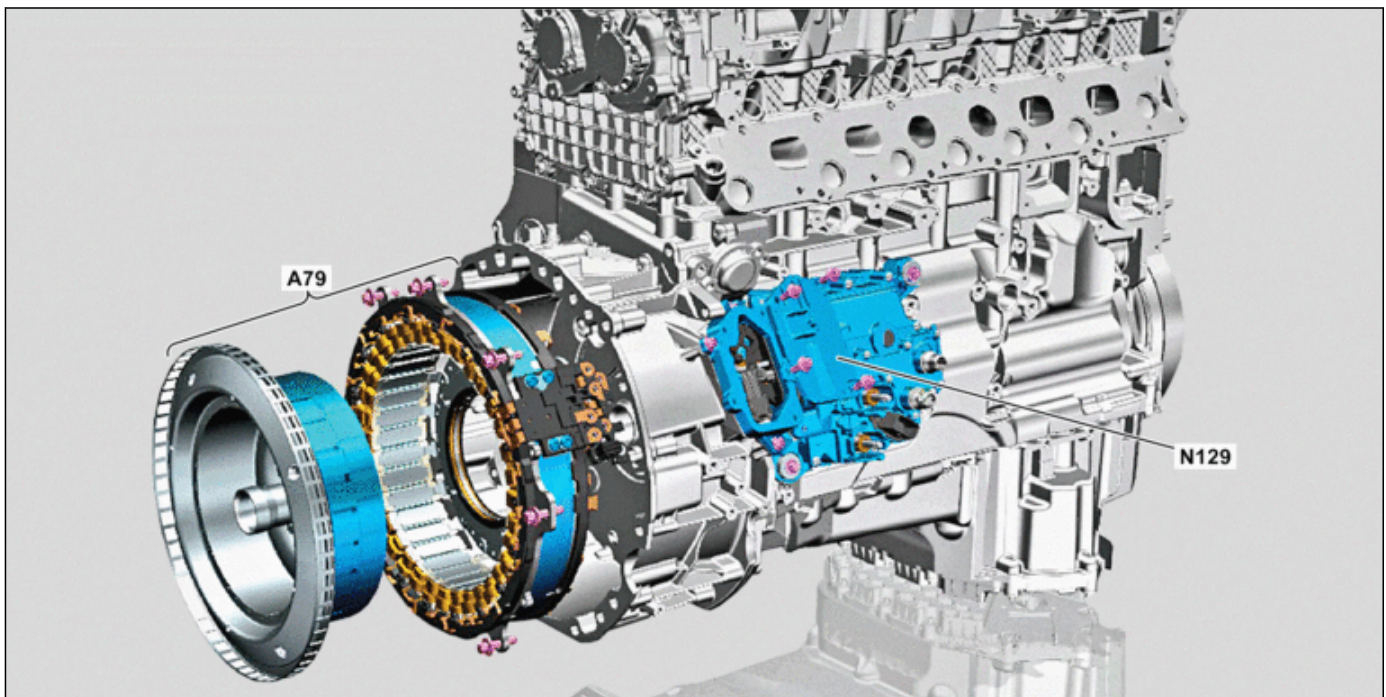

P54.00-3241-79

Exploded view of integrated starter alternator (A79)

A79 Integrated starter generator

N129 Starter generator control unit

Integrated starter generator

The M 256 sees Mercedes-Benz making a successful entry into a 48 V on-board electrical system. The energy storage unit used here is a 48 V lithium-ion battery with an energy content of almost 1 kWh. The battery was able to be integrated very compactly and combined with a delivery-on-demand cooling and heating system.

In the "P1 configuration", the integrated starter alternator is rigidly bolted to the crankshaft and is installed between the engine and the 9G-TRONIC automatic transmission. The power electronics are located in the installation space of the pinion starter, which is no longer installed.

The task of the integrated starter alternator is to exchange energy between the drive shaft and the 48 V on-board electrical system. It is operated here in two different ways.

In engine mode it can start a stationary combustion engine (starter) as well as accelerate an already rotating drive shaft, by supplying engine torque.

In generator mode, it can generate electrical energy (alternator) and it is responsible for supplying the 48 V on-board electrical system as well as for charging the 48 V on-board electrical system battery (G1/3).

The integrated design means that the torque is transferred without any integrated transmission elements between the integrated starter alternator and the crankshaft.

The control unit for the starter-alternator sets up the electrical connection between the three-phase AC system of the integrated starter alternator and the DC system of the 48 V on-board electrical system.

Built into the integrated starter alternator are a three-phase winding with permanent excitation, a resolver for acquisition of the angular position and two temperature sensors.

Engine view from below

<i>B40/6</i>	<i>Engine oil fill level sensor</i>
<i>N129</i>	<i>Starter generator control unit</i>

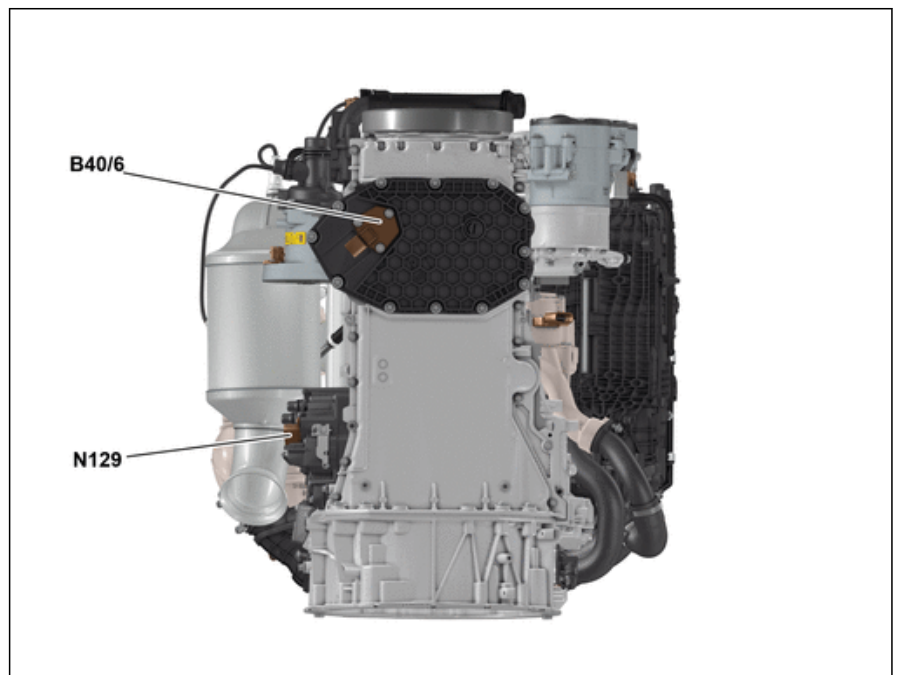

P01.10-3342-76

Charging

The objective behind the newly developed charging concept is to achieve the best response characteristic coupled with high engine outputs. The demanding installation space situation brought about by the exhaust gas emission control components located in the engine compartment, paired with the wish to achieve a high commonization level for the components in the engine family, were the decisive factors in opting for a single turbo concept.

In order to achieve an impressive response characteristic in the lower speed range with the 320 kW uprated engine, despite the naturally larger exhaust gas turbocharger, an electric additional compressor is used, that is integrated into the 48 V on-board electrical system.

The exhaust gas turbocharger installed in the M 256 is a "Twinscroll" exhaust gas turbocharger with air gap-insulated exhaust manifold, including flooding separation for cylinders 1 to 3 and 4 to 6. The high level of vertical integration enables a particularly high-quality low-nickel

steel to be used in combination with a special low pressure casting for the turbine wheel housing.

Special value was placed on backpressure-optimized gas routing, the design of the connecting point between the turbine wheel housing and manifold along with the leak tightness of the slip fits relative to each other. This design helps to significantly reduce charge change losses, while also providing an excellent exhaust gas turbocharger response characteristic even where exhaust flows are at their lowest.

Another advantage lies in the connection of low internal leakage rates and the manifold's air-gap insulation. This

helps to achieve a significant reduction in the surface temperature of the exhaust manifold thereby relieving the thermal situation on the "hot side" of the engine - in particular on highly dynamic drives or during postheating phases.

To reach the temperature required for exhaust gas cleaning in the catalytic converter quickly, the electrically-controlled wastegate and its forward stream were optimized for simulative best-possible equal distribution.

Design of charging system

9	Charge air cooler
50	Turbocharger
M16/6	Throttle valve actuator
M60/1	Electric additional compressor
Y101	Divert air switchover valve
A	Exhaust
B	Charge air downstream of charge air cooler (cooled)
C	Charge air downstream of exhaust gas turbocharger (uncooled)

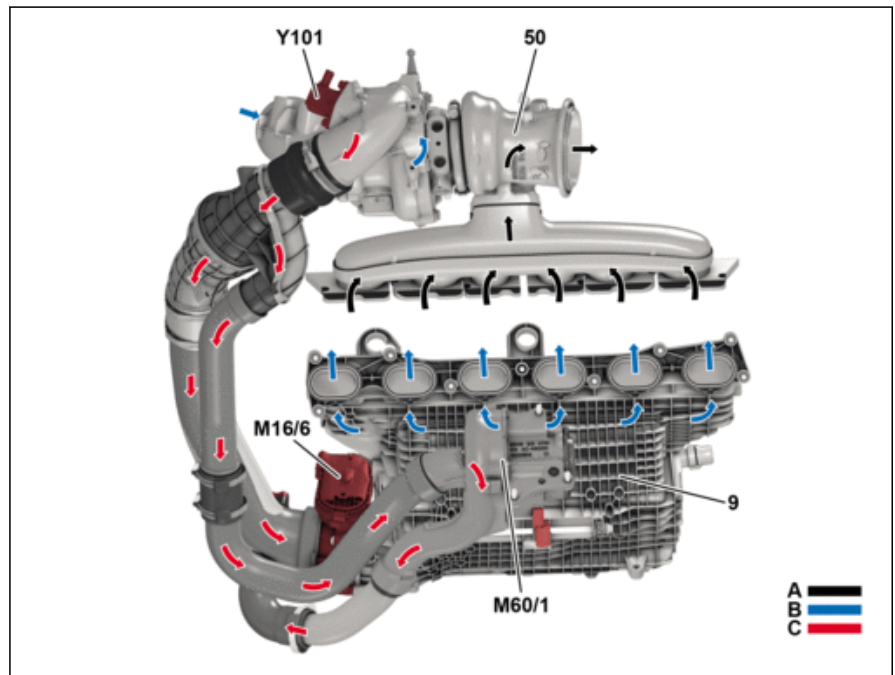

P09.00-2157-76

Forced induction function sequence

The function sequence is divided into the following subfunctions:

- **Function sequence for boost pressure control**
- **Function sequence for bypass air**
- **Function sequence for electric additional charging**

Function sequence for boost pressure control

Boost pressure control is carried out via the boost pressure control flap actuator (M16/7). The actuator is actuated in a characteristics map- and load-dependent manner by the ME-SFI [ME] control unit for boost pressure control. To do this the ME-SFI [ME] control unit evaluates signals from the following sensors and functions of the engine management:

- Charge air pressure and temperature sensor (B4/32), boost pressure and charge air temperature

- Pressure and temperature sensor upstream of throttle valve (B28/26), boost pressure and charge air temperature
- Pressure and temperature sensor downstream of turbocharger (B28/17), boost pressure and charge air temperature
- Pressure sensor downstream of air filter (B28/11), intake pressure
- Accelerator pedal sensor (B37), load request made by driver
- Crankshaft Hall sensor (B70), engine rpm
- Knock control, transmission overload protection, overheating protection

In wide open throttle operation, maximum boost pressure builds up.

In order to reduce the boost pressure, the exhaust flow for driving the turbine wheel is diverted via a bypass by opening the boost pressure control flap.

The boost pressure control flap actuator actuates - via a linkage - the boost pressure control flap that closes the bypass. Part of the exhaust flow is directed through the bypass past the turbine wheel, whereby the boost pressure is regulated and the turbine speed limited. In this way the boost pressure can be adapted to the current load demand on the engine.

To monitor the current pressure and temperature conditions in the charge air duct from the exhaust gas turbocharger to the charge-air distributor, the ME-SFI [ME] control unit evaluates the signals from the pressure and temperature sensors, and adjusts the boost pressure to the engine-related requirements.

Schematic diagram of exhaust gas turbocharger

- 1 Compressor
- 2 Turbine
- 3 To throttle valve
- 4 From exhaust manifold
- Y101 Divert air switchover valve
- A Fresh air
- B Exhaust gases

Function sequence for bypass air

The exhaust gas turbocharger continues turning for a period of time after the start of deceleration mode due to the inertia of the shaft, compressor and turbine wheel. In the case of rapid closing of the throttle valve, a charge pressure wave therefore runs back to the compressor impeller. This charge pressure wave would create a condition with a low delivery volume and high pressure conditions at the compressor impeller, which causes charger pumping (brief howling and mechanical stress). Opening the bypass air switchover valve prevents this through rapid depressurization through a bypass in the intake side of the ATL.

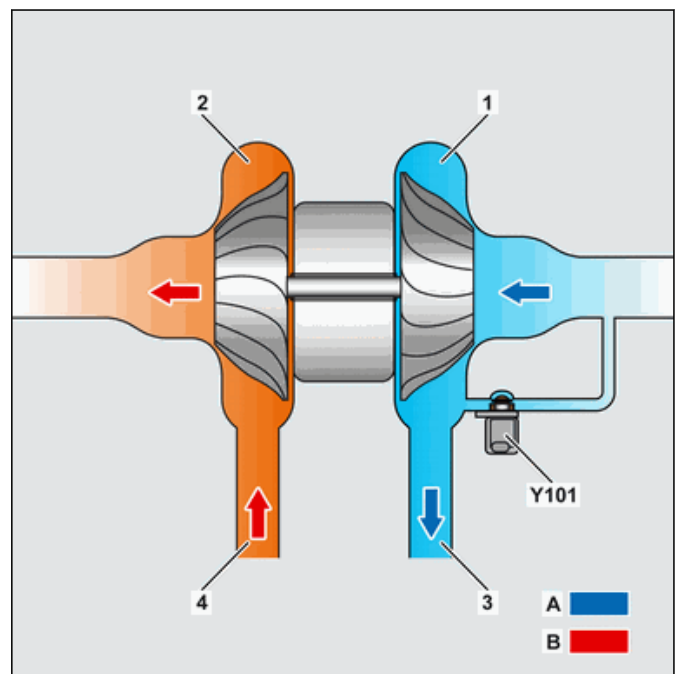

P09.40-2418-82

When the engine is being operated under load, boost pressure is applied to the diaphragm which then keeps the bypass closed.

If the engine is switched off, the diaphragm is pressed into the seat by a spring integrated into the deceleration air switchover valve. If the ME-SFI [ME] control unit detects through the actual value potentiometers (M16/6r1, M16/6r2) that the throttle valve has closed and therefore deceleration mode is active, the bypass air switchover valve is actuated. The diaphragm is pulled open against the

spring force and boost pressure and opens the bypass to the intake side. The excess boost pressure is thereby relieved.

If the engine changes from deceleration mode to load operation, the bypass air switchover valve is no longer actuated. The spring presses the diaphragm in the direction of the seat. The diaphragm is then pulled into the seat by the prevailing boost pressure thereby closing the bypass again.

Sectional view of deceleration air switchover valve

- 50 Turbocharger
- M16/7 Boost pressure control flap actuator
- Y101 Divert air switchover valve
- A Status: Closed
- B Status: Opened

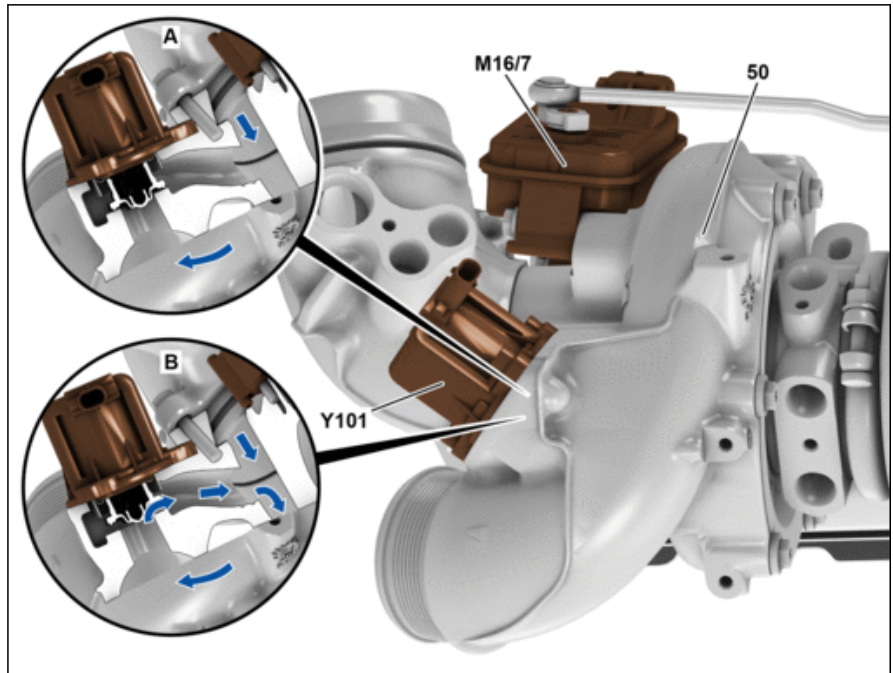

P09.40-2551-76

View of engine from left

- B4/32 Charge air pressure and temperature sensor
- B28/26 Pressure and temperature sensor upstream of throttle valve
- M16/6 Throttle valve actuator
- M60/1 Electric additional compressor

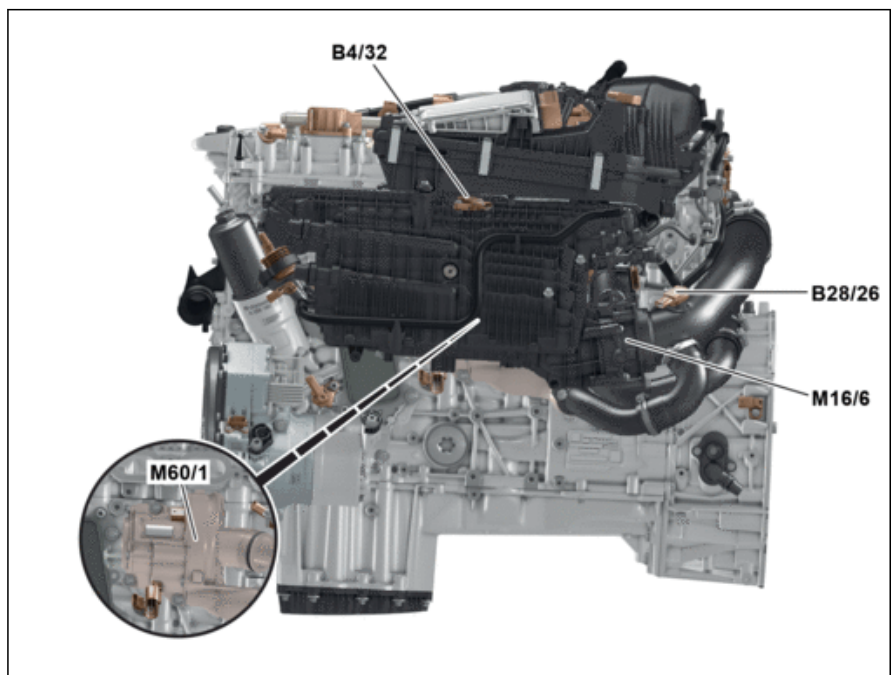

P01.10-3339-76

Function sequence for electric additional charging

The boost pressure is directly dependent on the rpm of the turbocharger that is driven by the exhaust flow. The boost pressure that can be generated by the turbocharger in the lower rpm range is therefore rather low, and only increases as the engine rpm increases. When high power is

demanded rapidly by the driver, it takes a certain time until maximum boost pressure can be built up so that the engine's full output is available. This behavior in supercharged engines is known as "turbo lag".

To counteract turbo lag and to have uniform high boost pressure available across the entire rpm range, part of the

boost pressure in the lower rpm range is generated by the electric additional compressor (M60/1). The available boost pressure can be up to a maximum of 450 mbar.

The engine management calculates the target boost pressure at any engine speed according to the load request, the operating state of the engine and the ambient conditions. As the exhaust gas turbocharger is unable to build up the target boost pressure in the low rpm range, the pressure difference between the actual boost pressure and the target boost pressure is compensated for by actuating the electric additional compressor. To do this, the engine management system calculates the additional compressor rpm metered to the required boost pressure.

The additional compressor is actuated over an internal CAN bus by the ME-SFI [ME] control unit in an rpm range up to 3,000 rpm.

The coolant-cooled, electric additional compressor used with its output of more than 5 kW provides a more spontaneous boost-pressure buildup. It is positioned on the cold side of the engine, briefly before the inlet into the charge air cooler where within a period of 300 ms it reaches a speed of up to 70,000 rpm, and a maximum pressure ratio of 1.45.

During additional compressor actuation, the signals of the pressure and temperature sensor downstream of the throttle valve are registered to monitor the boost pressure. When the turbocharger is running on its own, pressure measurement is carried out via the pressure and temperature sensor downstream of the turbocharger.

The electric additional compressor is located on the left engine side behind the charge air cooler between the exhaust gas turbocharger and the throttle valve.

Any malfunctions occurring are sent to the ME-SFI control unit and are logged there as faults. A nominal speed can be manually specified with the aid of XENTRY Diagnostics.

Exhaust treatment

As a member of the new engine family, the M 256 also pursues the concept of an near-engine mounted integration of the required catalytic converter volume, to enable heating to be as fast as possible following a cold start. The M 256 is also equipped with a state-of-the-art gasoline particulate filter (OPF).

The catalytic coating used is a new development and it is also optimized for back pressure. The lambda control takes place through a straight-line lambda sensor upstream of the catalytic converter and a planar sensor located between the two catalytic converters.

The complete catalytic converter box is fully insulated and has a modular design so that with the corresponding extensions global emission standards can be met. The gasoline particulate filter (OPF) positioned in the first expansion stage in the underbody, provides an effective means of significantly reducing the number of particulates. The operating principle of the gasoline particulate filter (OPF) technology is based on the diesel particulate filter concept. Along with the sufficiently high degree of particulate separation, the lowest-possible increase in exhaust gas backpressure by the gasoline particulate filter (OPF), is a decisive feature when using the vehicle.

The gasoline particulate filter (OPF) volume itself was selected so that, on the one hand, an optimum filtration efficiency is achieved, while on the other hand providing sufficient volume for oil ash deposition in the OPF as mileage increases. Altogether the modular design concept provides a high-performance, backpressure-optimized emission control system, that is ideal for dealing with emissions under real-life driving conditions (high output density emission) for the new M 256.

Exhaust treatment

- 30 Catalytic converter box
- 31 Gasoline particulate filter

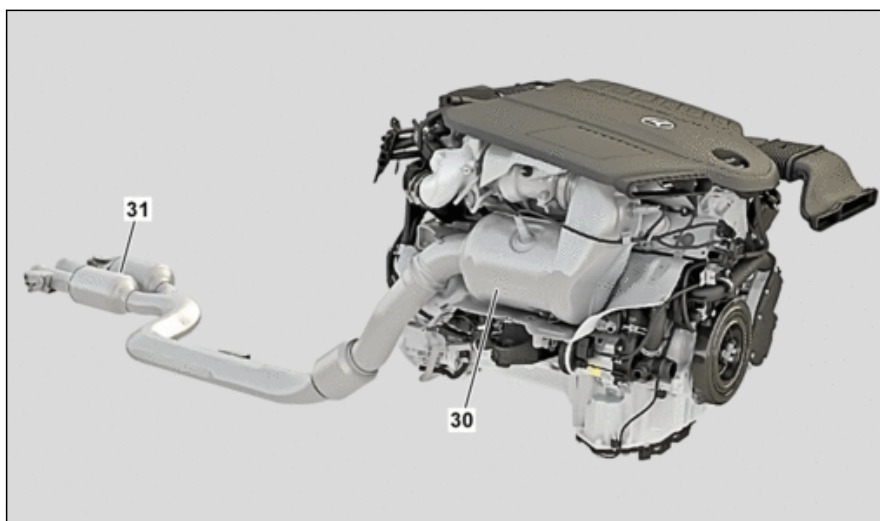

P14.00-2180-75

Location of exhaust system

30	Catalytic converter box
31	Gasoline particulate filter
32	Center muffler
33	Rear muffler
G3/1	Oxygen sensor downstream of catalytic converter
G3/2	Oxygen sensor upstream of catalytic converter
M16/53	Left exhaust flap actuator motor
M16/54	Right exhaust flap actuator motor

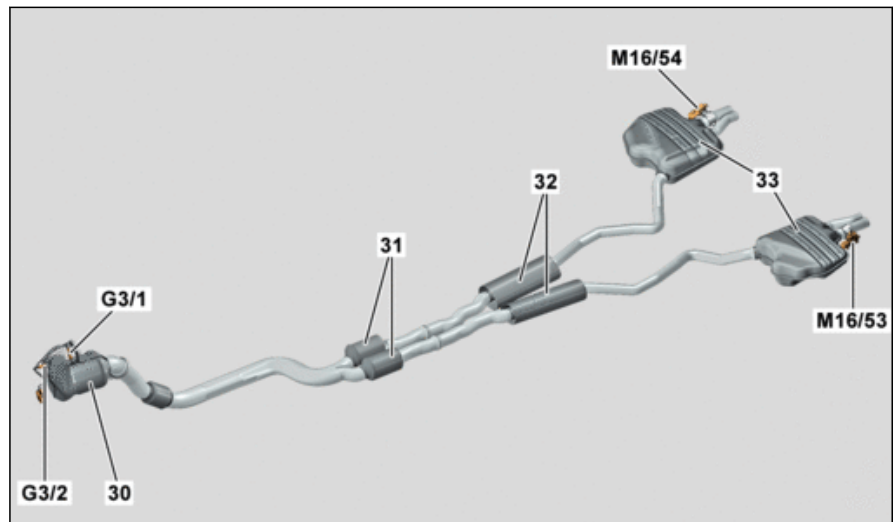

P49.00-2199-75

Exhaust system

The main exhaust system tasks are:

- Cleaning the combustion gases
- Discharge of combustion emissions from the vehicle
- Dampening of pressure surges that are generated by the explosive combustion in the combustion chambers.
- Reduction of noise emissions

The design of the exhaust system exerts a distinct influence on the available torque in the engine's usable rpm range.

The exhaust system participates passively in the charge change, the shape of the system influences the vibrations of the exhaust gas located in it. These vibrations support the discharge of the combustion gases from the combustion chamber when the exhaust valve is opened.

The best result is achieved with the aid of variable timing and a flap-controlled exhaust system.

The exhaust gas flap actuator motors operate the exhaust gas flaps in each exhaust tailpipe to minimize the noise level in the exhaust system.

The exhaust gas flap actuator motors are actuated by the powertrain control unit (N127) by map-dependent control.

Here, the exhaust gas flaps can be fully closed or opened or they are continuously adjusted in a stored intermediate position according to the characteristics map used.

The exhaust gas flap actuator motors can be diagnosed, and if the exhaust gas flaps are not opened, they send feedback to the powertrain control unit, which then reduces engine output.



Depending on the set drive program, various characteristics maps are stored for the opening characteristics of the exhaust gas flaps in the control unit.

View of engine from front right

25 Coolant thermostat
M75/11 Electric coolant pump

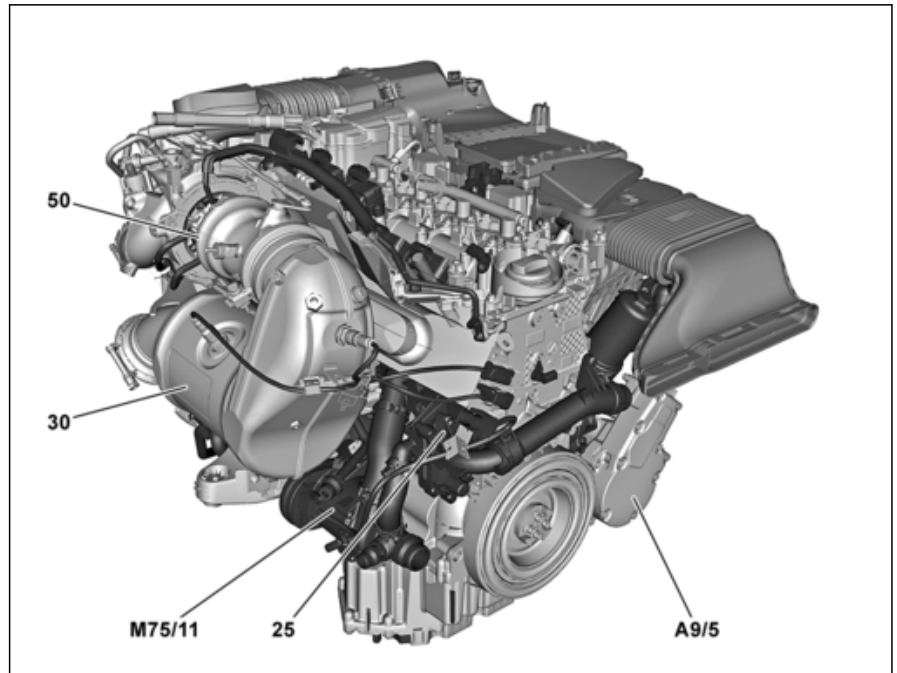

P01.10-3415-06

Electric coolant pump

The electrical coolant pump is located at the front right on the engine, below the exhaust system.

The electric coolant pump ensures needs-based circulation of the coolant in the engine's high-temperature circuit.

The electric coolant pump is actuated by the ME-SFI [ME] control unit (N3/10) through a LIN signal. When this occurs, it is regulated after the following signals have been evaluated:

- Coolant temperature
- Heater request
- Engine speed
- Engine torque

At a coolant temperature of less than 75 °C, the electric coolant pump is deactivated, unless the control unit for the climate control (N22/1) requests pumping capacity from the electric coolant pump.

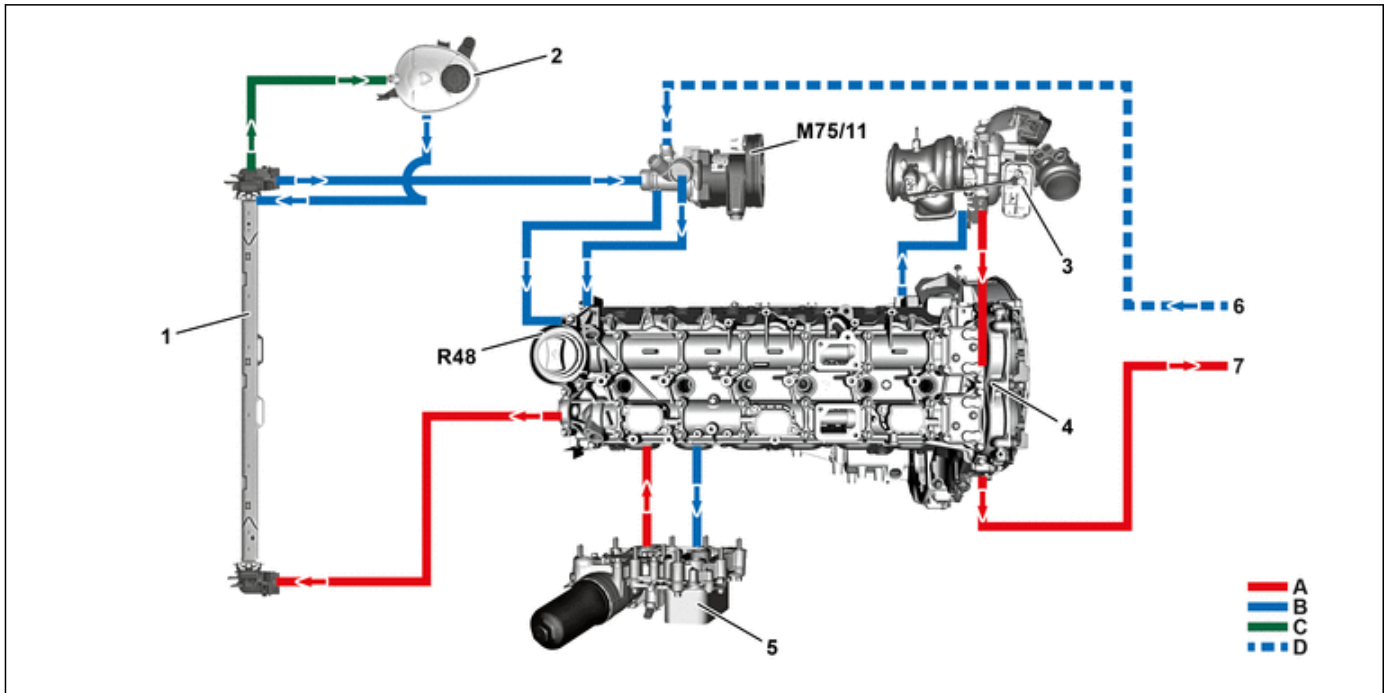

P20.10-2499-79

Engine cooling circuit

- | | | | |
|---|-----------------------------------|--------|------------------------------------|
| 1 | Radiator | M75/11 | Electric coolant pump |
| 2 | Expansion reservoir | R48 | Coolant thermostat heating element |
| 3 | Turbocharger | A | Hot coolant, return |
| 4 | Combustion engine | B | Cold coolant, feed |
| 5 | Oil module with engine oil cooler | C | Ventilation/coolant expansion |
| 6 | Heater return | D | Cold coolant, heater return |
| 7 | Heater feed | | |

Low temperature circuits 1 and 2

Low-temperature circuit component description:

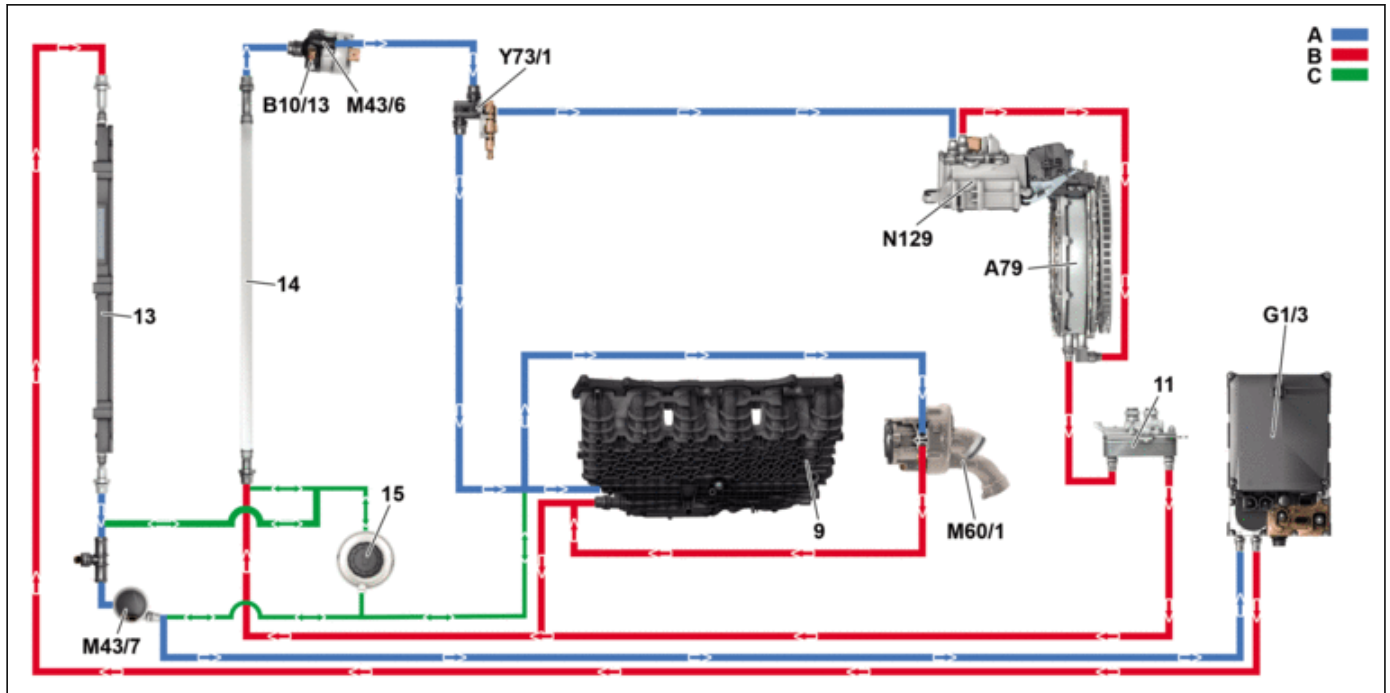

P20.00-2599-79

View of low temperature circuit

9	Charge air cooler	M43/6	Low temperature circuit circulation pump 1
11	Transmission oil cooler	M43/7	Low-temperature circuit circulation pump 2
13	Low-temperature circuit 2 cooler	M60/1	Electric additional compressor
14	Low-temperature circuit 1 cooler	N129	Starter generator control unit
15	Coolant expansion reservoir for low-temperature circuit 1 and 2	Y73/1	Low-temperature circuit switchover valve
A79	Integrated starter generator	A	Low-temperature circuit 2
B10/13	Low-temperature circuit temperature sensor	B	Low-temperature circuit 1
G1/3	48 V on-board electrical system battery	C	Expansion reservoir coolant line

Electric refrigerant compressor

The electric refrigerant compressor is located at the left on the engine.

The electric refrigerant compressor is responsible for intake and compression of the refrigerant. The electric refrigerant compressor is continuously speed-controlled to match the evaporator temperature from 700 to 9000 rpm.

The electric refrigerant compressor is switched off depending on the outside temperature, the temperature of

the high-voltage battery as well as after an accident. If the outside temperature $< 2\text{ }^{\circ}\text{C}$, the electric refrigerant compressor is generally switched off.

The climate-control control unit (N22/1) actuates the electric refrigerant compressor via the climate control LIN 2 (LIN B8-2).

View of engine from front left

- A9/5 *Electric refrigerant compressor*
- M75/11 *Electric coolant pump*

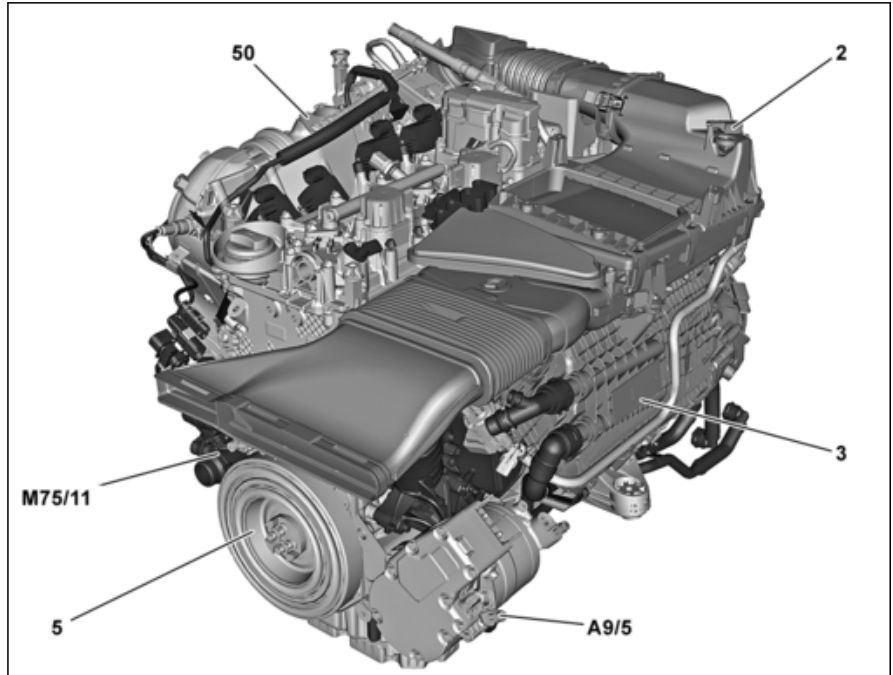

P01.10-3414-06

Electric refrigerant compressor (A9/5)

- 1 *Spiral compressor*
- A9/5 *Electric refrigerant compressor*
- A9/5m1 *Refrigerant compressor electric motor*
- A9/5n1 *Refrigerant compressor control unit and power electronics*

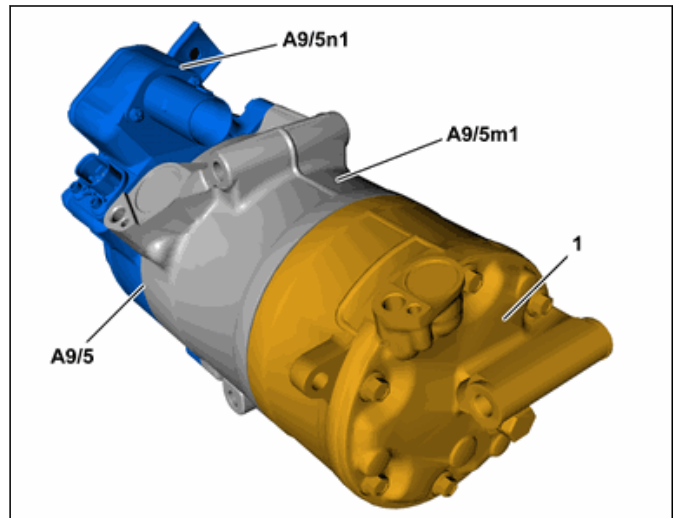

P83.55-2199-81

Structure

The electric refrigerant compressor control unit regulates the rotational speed of the electric motor and the quantity of refrigerant.

The electric motor drives the spiral compressor.

This consists of two intertwined spirals, one of which is permanently connected to the housing while the second rotates in a circle in the first one.

The spirals here form several increasingly smaller chambers within the coils. In these chambers, the refrigerant compressed in this manner reaches the center, where it then exits compressed.

Maintenance

The current Mercedes-Benz maintenance strategy also applies to M 256, country-specific deviations are possible:

- Europe: Fixed maintenance intervals with interval "every 25,000 km/12 months".
- China: Fixed maintenance intervals with interval "every 10,000 km/12 months".
- USA: Fixed maintenance intervals with interval "every 10,000 mi/12 months".
- Service A and B always alternate

Additional operations are conducted during these intervals (example: Europe):

- Replace air filter element: Every 75,000 km/3 years
- Replace spark plugs: Every 75,000 km/3 years
- Replace fuel filter, spark-ignition engines: 200,000 km/10 years

Draining of engine oil

The M 256 no longer has an oil suction pipe and therefore no oil dipstick.

The engine oil is drained using a drain screw in the oil pan. The engine oil level is checked using a sensor in the oil pan and through the display on the instrument cluster. This is called up using the steering wheel buttons.

The procedure for the engine oil level measurement/oil change is available in WIS document AP18.00-P-1812MKI (using OM 654 in model 213 as an example).

Engine oils

The use of a gasoline particulate filter (OPF) here, means that on this engine the engine oil change is to be conducted with low-ash engine oil, as for engines equipped with a diesel particulate filter (DPF). For service purposes, the following engine oils are approved as per the Mercedes-Benz Specifications for Operating Fluids:

- 229.51
- 229.52
- 229.61
- 229.71

 Technical data:

Shown here M 256 E 30 DEH LA R

A Performance curve

B Torque curve

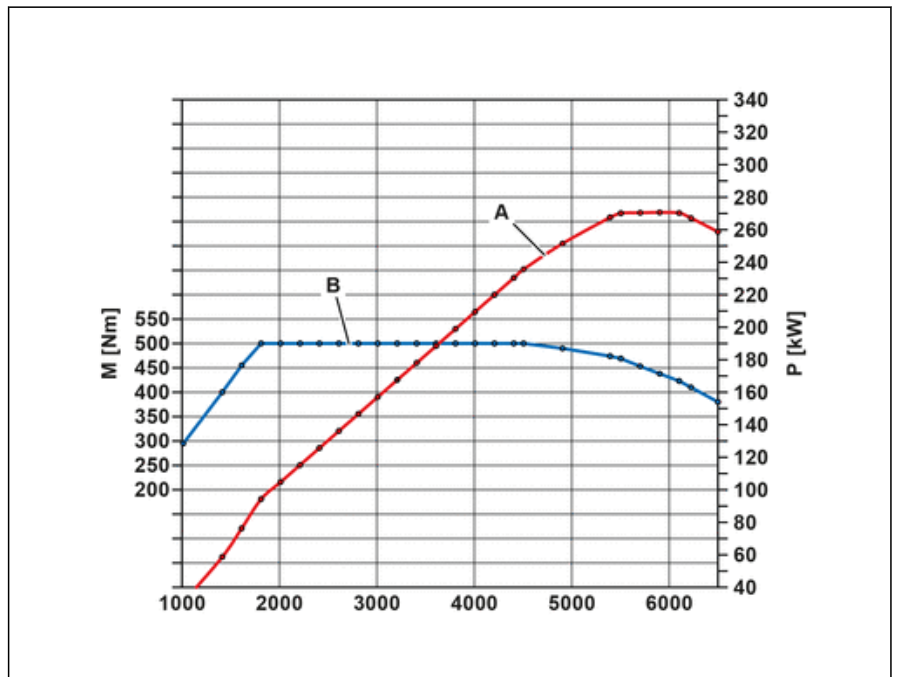

P01.00-3720-76

Shown here M 256 E 30 DEH LA G

- A Performance curve
- B Torque curve

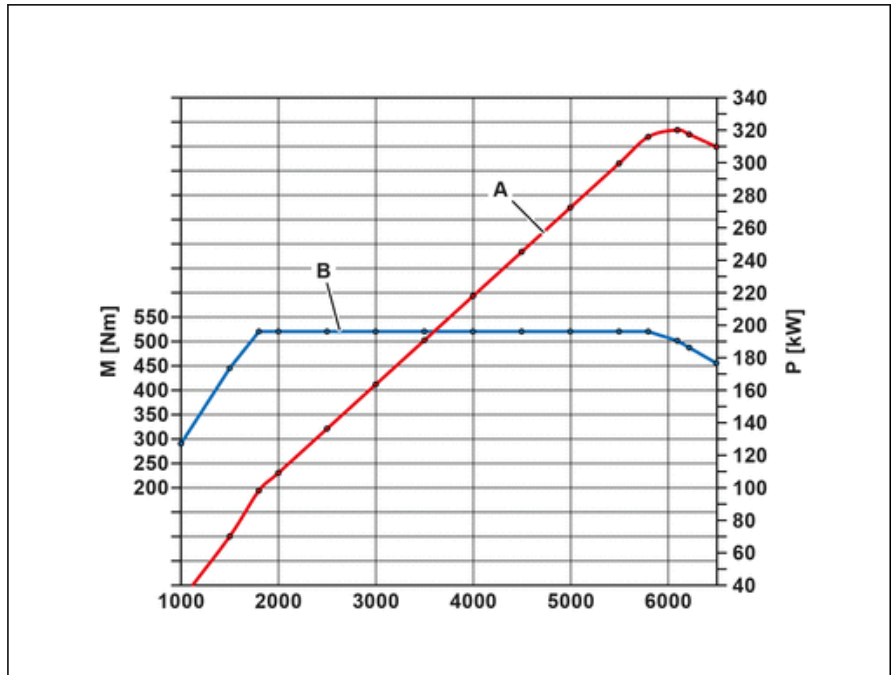

P01.00-3721-76

Variants of M 256 for market launch in model 222

M 256	Displacement in l	Output (without ISA) in kW	Torque (without ISA) in Nm
M 256 E30 DEH LA R	3.0	270	500
M 256 E30 DEH LA G	3.0	320	520

Technical data M 256

Motor	M 256 E30 DEH LA R (reduced output)	M 256 E30 DEH LA G (increased output)
Configuration/cylinder number	Inline/6	Inline/6
Cylinder-bore spacing in mm	90	90
Bore x stroke in mm	83 x 92	83 x 92
Stroke/bore	1,1	1,1
Swept volume in cm ³	2999	2999
Compression in ε	10,5	10,5
Rated output kW at rpm	270 at 5500 to 6100	320 at 5900 to 6100
Specific output in kW/l	90	106.7
Maximum torque Nm at rpm	500 at 1800 to 4500	520 at 1800 to 5500
Exhaust variant	Euro 6 Standard 2	Euro 6 Standard 2