

GLS SUV



X167

Model Year 2020

Preliminary – Subject to Change

Mercedes-Benz

The best or nothing.





Important note

The information presented in this guide is based on the most current information available and is intended for internal use only. Mercedes-Benz reserves the right to make changes at any time, without notice, to colors, materials, equipment, special specifications and models.

Pricing may not yet be finalized for some models or options.

Due to variances among monitors and printers the colors that appear on your screen and printouts may not be exact.

For illustrative purposes, some images may show vehicles with European Specification.

Revision History

<i>Date</i>	<i>Changes</i>
04/17/2019	All-new model initial release – prices subject to change
04/24/2019	Removed restriction on 958 interior. Added Off-Road Package (DA9PKG) for GLS 580



GLS 450 4MATIC & GLS 580 4MATIC



Models



What's new



Standard Equipment

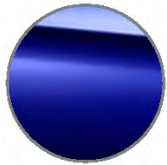

Exterior Paint Colors



Wheels



Interior Upholstery



Interior Trims



Option Packages



Stand-Alone Options



Options in Detail



Specifications



GLS 450 4MATIC (167.959)

- MSRP \$ 75,200
- 3.0L Inline-6 Turbo Engine with EQ-Boost
- Horsepower 362 hp
- Torque 369 lb-ft
- EQ Boost Outputs 21 hp and up to 184 lb-ft
- 5.9 sec est. (0-60 mph)
- Launch date: Q3/2019 (MY20)



GLS 580 4MATIC (167.986)

- MSRP \$97,800
- 4.0L V8 Bi-Turbo Engine with EQ-Boost
- Horsepower 483 hp
- Torque 516 lb-ft
- EQ Boost Outputs 21 hp and up to 184 lb-ft
- 5.2 sec est. (0-60 mph)
- Launch date: Q4/2019 (MY20)

Pictures show European Model



Exterior Comparison MY19 (X166) vs. MY20 (X167)



European picture shown

Interior Comparison MY19 (X166) vs. MY20 (X167)



Picture shows optional Equipment



Picture shows optional Equipment



Interior Highlights



Two dominant grab handles on the center console



Enlarged panoramic sliding sunroof with 50% larger viewing area



Trims w/ new matching center console

New generation steering wheels with touch buttons



Ambient lighting with 64 colors

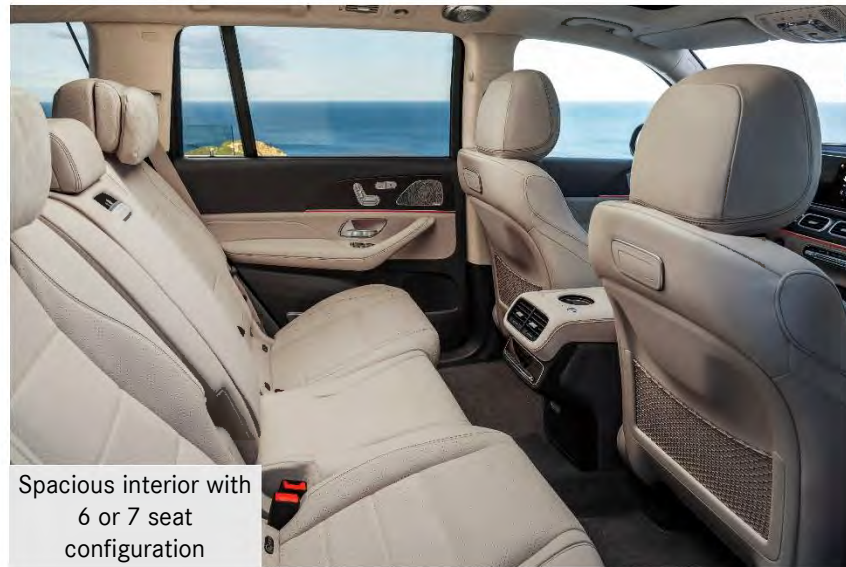

Spacious interior with 6 or 7 seat configuration



MBUX

New air vent design



Exterior

- Greater length, width, wheelbase and track width
- Emotional and dynamic design
- Hood with two prominent power domes
- Free-standing roof rails in chrome finish
- Dark wheel arch claddings
- New: large 19-23" wheels
- Distinguished, chrome underride guard in SUV-specific design
- New exterior paint colors

Interior

- Progressive all-new SUV interior design
- New generation steering wheels with touch control buttons
- Instrument panel and center console visually divided and redesigned
- Trim elements with open-pore woods
- Two dominant grab handles on the center console
- SUV-specific storage compartments

Standard Equipment

- LED Intelligent Light System
- MBUX User Interface incl. Voice Control with Natural Language Understanding
- MB Navigation
- 12.3" Digital Instrument Cluster
- 12.3" Media Display with Touchscreen
- 6 or 7 Seat Configuration
- Ambient Lighting with 64 Colors and Illuminated Door Sills
- Active Parking Assist with Surround View
- Memory Function for Passenger Seat
- 115V Household Type Power Outlet
- Touchpad in Center Console
- 9 USBs Type-C (3 in front, 2 in 2nd row, 4 in 3rd row)
- Blind Spot Assist
- Wireless Charging
- Burmester® Surround Sound
- SiriusXM® Radio
- KEYLESS-GO
- HANDS-FREE ACCESS

Optional Equipment

- AIR-BALANCE Package (P21)
- Head-Up Display (463)
- E-ACTIVE BODY CONTROL Package (DC7PKG)
- 4/5-Zone Climate Control (581/582)
- Enlarged panoramic sliding sunroof with 50% larger viewing area (413)
- Illuminated running boards with robust stainless-steel inserts (846)
- Executive Rear Seat Package/Executive Rear Seat Package Plus (DB5PKG/DB6PKG)
- MBUX Interior Assistant (Gesture Control) (77B)
- MBUX Augmented Reality for Navigation (U19)



MY 20 GLS Seating Choices

No additional Pricing.

7 Seat Configuration (226)

2 + 3 + 2 Seats

*Required for Executive Rear Seat Package (DB5PKG)
and Executive Rear Seat Package Plus (DB6PKG)*

or

6 Seat Configuration (224)

2 + 2 + 2 Seats

Individual Seats with Armrests in 2nd row

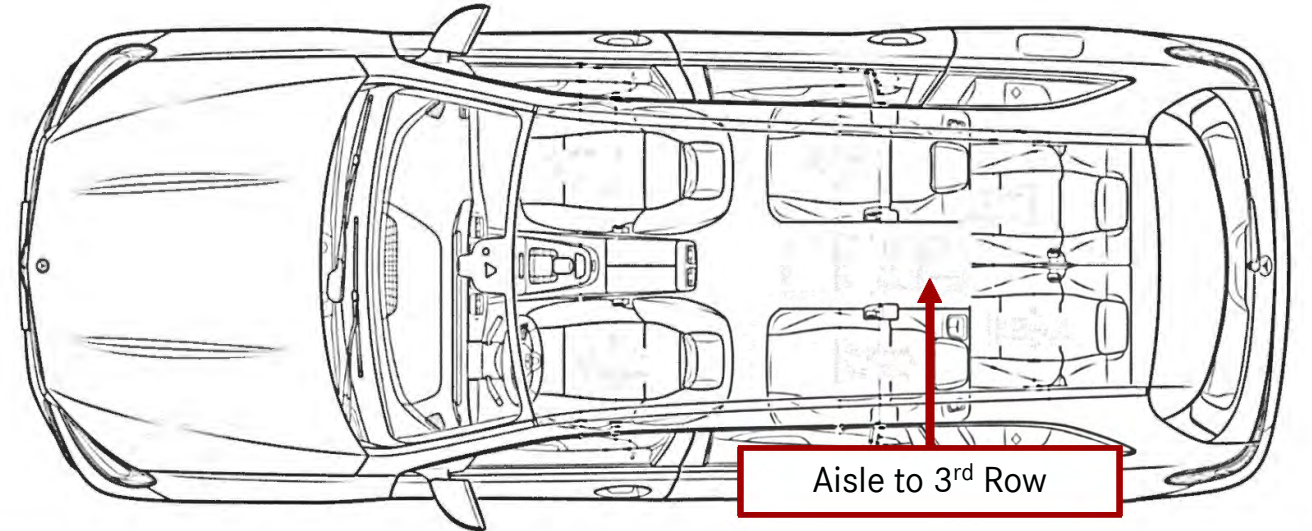
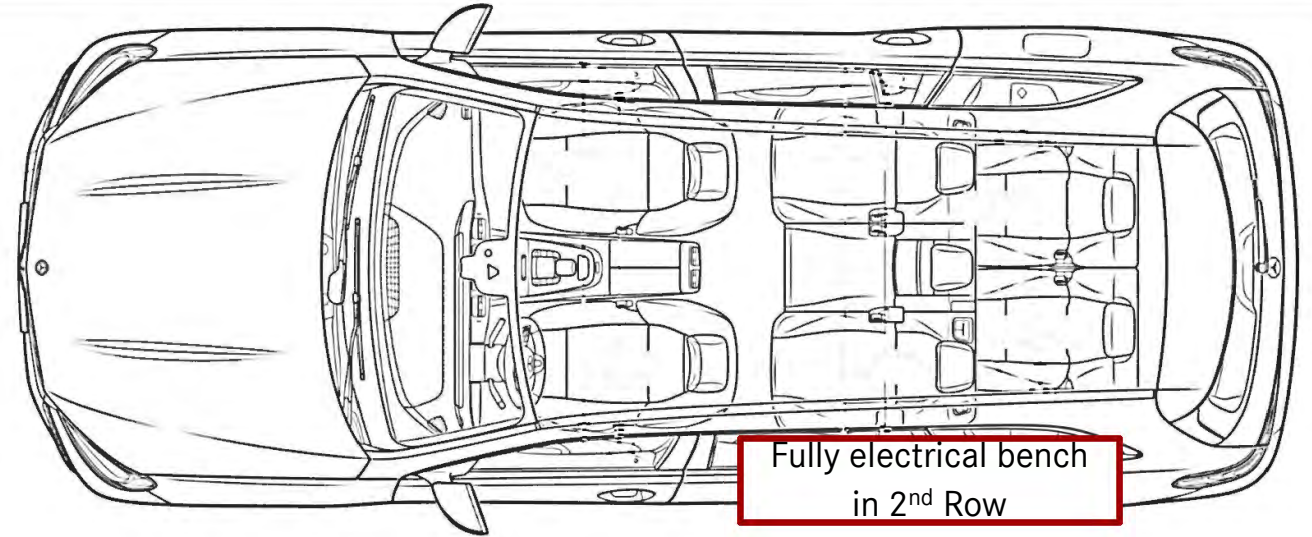



E-ACTIVE BODY CONTROL Package (DC7PKG)



E-ACTIVE BODY CONTROL Package (DC7PKG)

Option Price: \$6,500

Optional on all GLS models

Requires tire diameter 790 (wheel size 20" or larger)

E-ACTIVE BODY CONTROL is an all-new suspension system powered in part by the 48V battery and developed by Mercedes-Benz. By utilizing a Road Surface Scan and curve inclination function, an extraordinary level of comfort is made possible, and supports the claim of Mercedes-Benz to build the world's most intelligent SUV suspension.

- Only system on the market to control spring and damping forces individually at each wheel
- Hydropneumatics generate dynamic forces that overlay the air suspension forces and actively support and dampen the vehicle body during linear and lateral acceleration or when driving on uneven roads

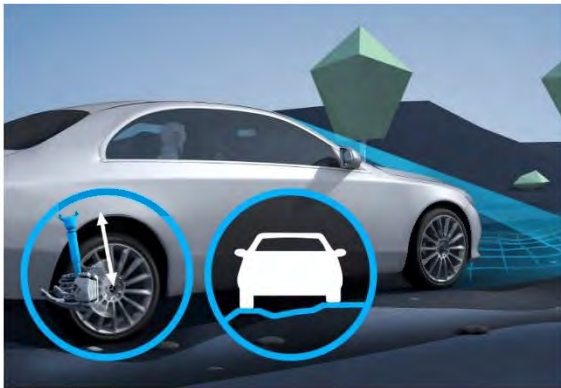

Mercedes-Benz User Experience (MBUX)

MBUX - the newest head unit generation from Mercedes-Benz

Standard on all GLS models

- Offered with two 12.3" digital displays as standard equipment
- MBUX was designed for a touch interface with intuitive operation
- There are four ways of interacting with the system:
 - An all-new Touchpad, Touch Control Buttons on the steering wheel, a touchscreen center display, and an all-new generation of Voice Control
- Multiple users can set up Profiles which save their settings for future use
 - Including: seat settings, music preferences and radio settings, phone settings, themes/moods, Bluetooth connections, etc.
- Over time, the system learns more about it's owners and creates Suggestions based on past behavior of the user
- Whole groups of settings can be saved together in the form of a Theme/Mood
 - Including: ambient lighting, climate control, music preferences, and setup of the Digital Instrument Cluster and head unit display, etc.
- Using over-the-air updates, MBUX can continuously be improved over time
- The system is very quick and responsive due to it's impressive graphics processing and computing power

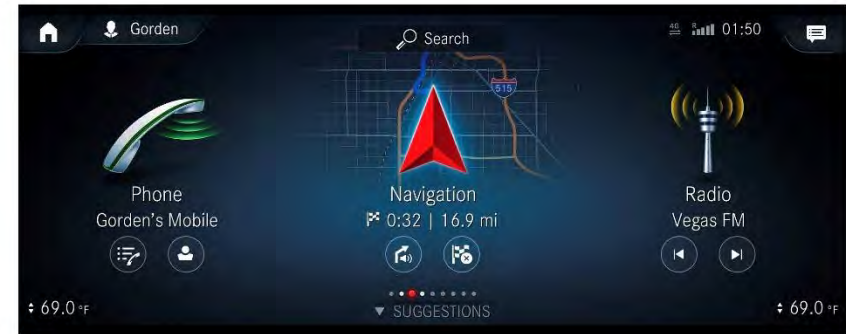

Voice Control

The most advanced Voice Control in any Mercedes-Benz vehicle

Standard on all GLS models

- Voice Control with MBUX is greatly enhanced over other systems by using both an onboard and offboard system for voice recognition
 - This ensures quick and appropriate responses
- The system also uses Natural Language Understanding so there's no need to remember the order of words for a specific command, just talk to the voice assistant as you would speak to another person
 - There are many ways of saying the same thing: *"Take me to Starbucks"*, or *"Find a Starbucks nearby"*, or *"Is there a Starbucks close?"*, or even *"I need a coffee"*
- Indirect commands can also be given like *"Will I need an umbrella today?"* and the Voice Control system understands that the user is really asking whether it will rain today
- In-vehicle components can also be controlled via Voice Control, like seat heating, climate control, ambient lighting, massage programs, and even the sunshade for the Panorama roof
- Voice Control is also capable of learning from its users and adjusting its understanding to their specific way of speaking
- Keyword Activation ensures you can quickly interact with Voice Control without having to press the button on the steering wheel
 - The system wakes up with a simple *"Hey Mercedes"* or *"Hi Mercedes"*

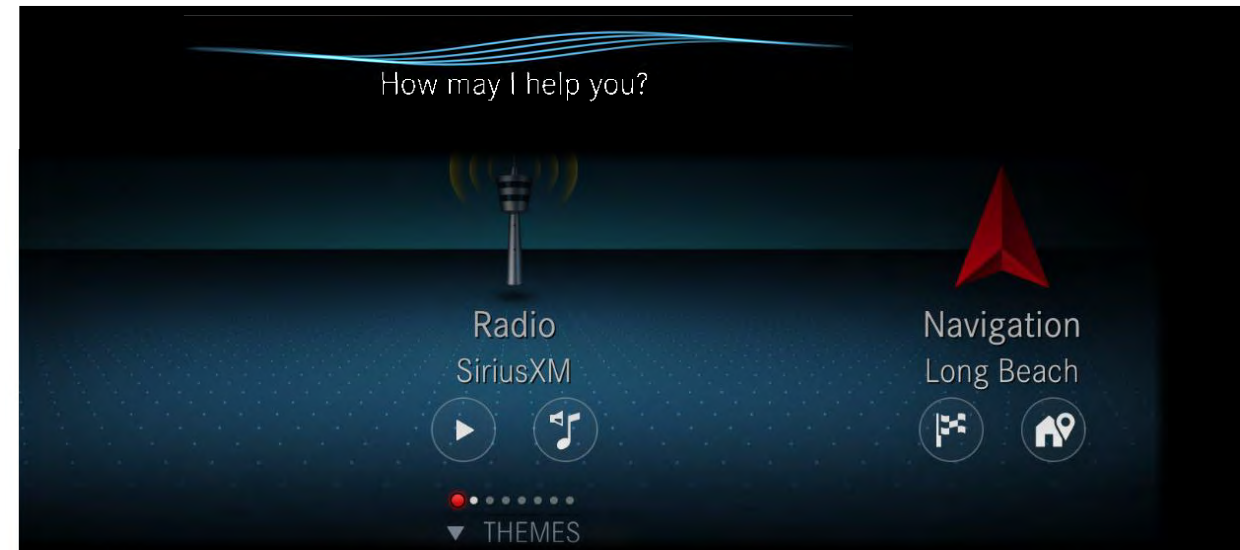

MBUX Interior Assistant (Gesture Control)



MBUX Interior Assistant (77B)

Option Price: \$300

Not w/ Burmester® High-End 3D Surround Sound System (811)

Enjoy contactless ease of operation: this innovative system detects and interprets your hand and arm movements. As such you can activate selected functions in a matter of seconds. As part of this the system is able to differentiate between driver and front passenger – so that you reach precisely the menus you wish to use.

- 3D camera in the overhead control panel, proximity sensors near the media display and touchpad
- The system detects and interprets hand movements and as part of this differentiates between the driver and front passenger
- Specifically highlights certain elements in the media display or enlarges them (media/radio, seat adjustment, navigation or Active Parking Assist)
- Activate reading lamp – by moving hand up and down beneath rear-view mirror
- Activate search light – stretch hand out towards the unoccupied front passenger seat
- Call up the personal favorites menu – defined gestures, form a "V" using index and middle fingers. This feature is customizable for both driver and passenger



Steering Wheel (L3B)



3-Spoke Nappa Leather Multifunction Steering Wheel (L3B)

Standard on all GLS models

The newly redesigned 3-spoke multifunction steering wheel in nappa leather combines a sporty design, compact dimensions and fine materials.

- Steering wheel shift paddles integrated into the back of the steering wheel cross spokes enable manual gear shifting and support a sporty driving style
- Steering wheel shift paddles in the steering wheel color
- Optional Active Distance Assist DISTRONIC® or standard cruise control is controlled via steering wheel-mounted controls
- Touch Control buttons for direct control of the instrument cluster and to control the functions of the multimedia system



Touchpad Controller (448)



Touchpad Controller (448)

Standard on all GLS models

The functions of MBUX can be controlled intuitively via the innovative touchpad, using single or multi-finger gestures (multi-touch):

- Touchpad approx. 3.35 x 3.54 inches in size
- Additional full-fledged input option supplementing the central controller, Touch Control Buttons on the steering wheel and voice control
- Recognizes single or multi-finger gestures (multi-touch), swiping movements and zoom gestures achieved by spreading the fingers or pinching them together
- Innovative handwriting recognition feature: Users are able to input letters, special characters and numbers in their normal handwriting, in any language available in the headunit
- 3 buttons located on the touchpad allow fast and direct operation of important functions
- Clear haptic feedback when using the touchpad or keys



Head-Up Display (463)



Head-Up Display (463)

Option Price: \$990

Optional on all GLS models

The Head-Up Display at a glance:

- Key driver information at a glance (e.g. speed, speed limits, navigation prompts, warnings or settings for the driving assistance systems) without the driver having to take their eyes off the road
- Projection of a virtual image measuring approx. 9.45" x 3.15" into the driver's field of vision
- Presentation of information in high-resolution and in color, making it clearly legible even on sunny days and at night
- Height position of the image, brightness and displayed content can be changed individually via a menu in the instrument cluster and can be stored conveniently via the optional memory function for the driver's seat



Ambient Lighting with 64 Colors (876)



Ambient Lighting with 64 Colors (876)

Standard on all GLS models

Showcase the interior according to your personal preferences or current mood. With a total of 64 colors, the ambient lighting gives you almost unlimited scope for lighting schemes, and has the right color available for any situation. Additional light elements in white help to ensure good orientation.

- All colors can be individually selected
- Brightness of the illumination zones can be freely selected between 0 and 100%
- Nine color schemes with different color combinations are pre-programmed
- Dynamic mode: atmospheric color changes thanks to slow, seamless transition between different colors
- Climate effect: feedback in color when changing the temperature setting
- Welcome effect: special light display when getting into the vehicle
- Incorporation of ambient lighting into the programs of the ENERGIZING comfort control, in conjunction with ENERGIZING package Plus
- Illuminated door sill panels with “Mercedes-Benz” lettering



ENERGIZING Package Plus (DB8PKG)



ENERGIZING Package Plus (DB8PKG)

Option Price: \$2,100

Requires Warmth and Comfort Package (DB0PKG)

The ENERGIZING package Plus is a new feature – it offers ultimate comfort for all the senses. To this end, a maximum of premium features are combined with innovative intelligence.

The exciting result: your Mercedes can vitalize and pamper you in specific ways. For prolonged alertness at the wheel and a very pleasant drive.

Programs

- The "Refresh" program brings a breath of fresh air on board – an intense airflow and activation of the seat ventilation create a revitalizing atmosphere
- "Vitality" gives you new energy – e.g. by including lively music
- Cozy relaxation is the purpose of "Warmth", which activates the seat heating
- If you opt for "Joy", the focus is on an invigorating massage with wave-like lumbar movements
- Your seat also pleases you in the "Comfort" program – in this program you can enjoy both seat heating and a beneficial hot-stone massage with a pulsating lumbar effect
- "Training", on the other hand, is active rather than passive: you can put intermediate breaks to good use with exercise

 Additional functionality with Garmin® wearables (Smartwatch/Fitness Trackers)



Availability of Heated & Ventilated Front Seats (401) with MB-TEX



Heated & Ventilated Front Seats (401)

Option Price: \$450

Will be available with MB-TEX for the first time

The climatized seats for driver and front passenger comprise seat heating and seat ventilation – for an ideal seat climate all year round. On hot days they provide you with a pleasantly refreshing temperature thanks to cooling ventilation. On cold days, meanwhile, the seat cushions and backrests emit a pleasant warmth.



9G-TRONIC Automatic Transmission (421)

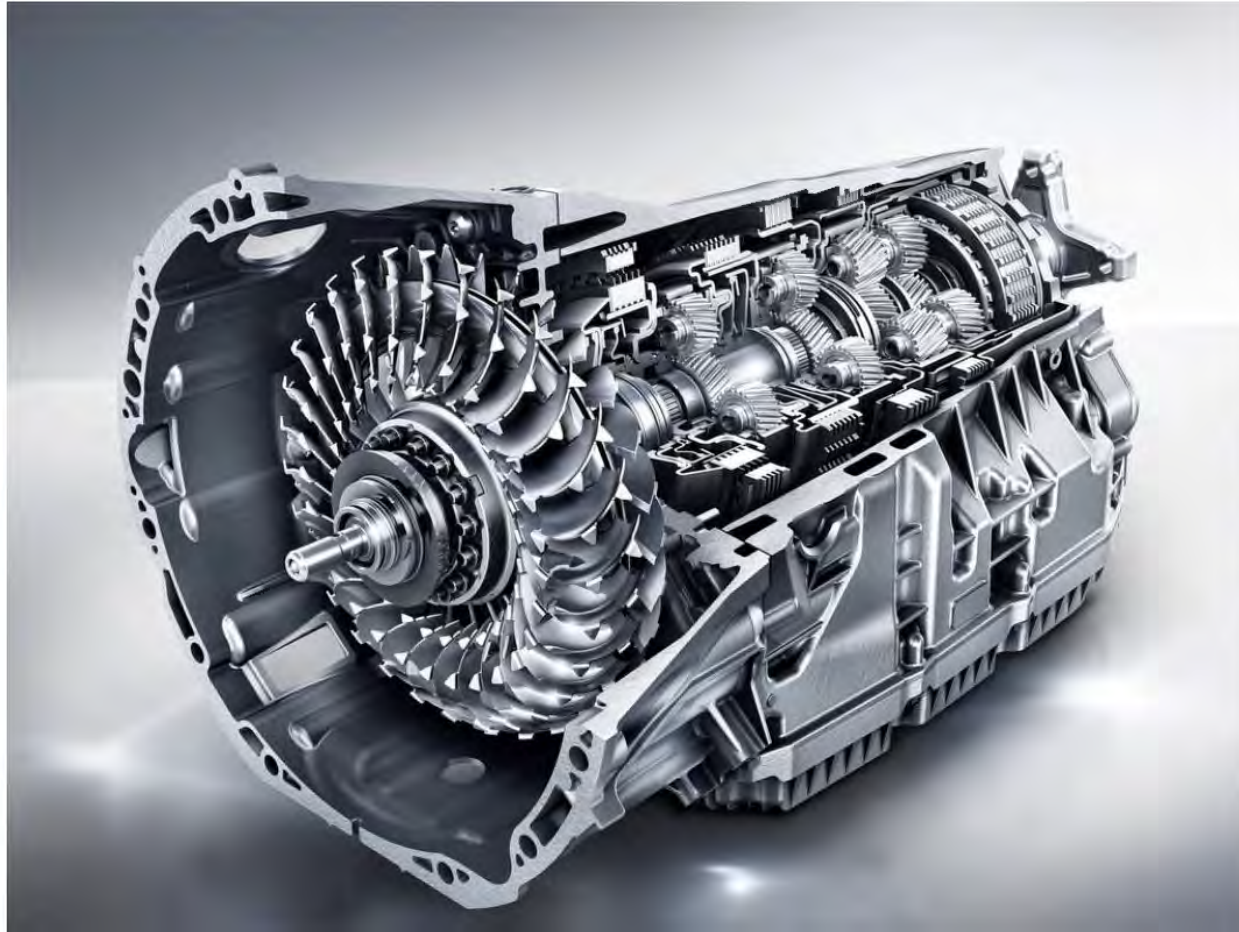

9G-TRONIC 9-Speed Automatic Transmission (421)

Standard on all GLS models

9G-TRONIC – faster, smoother, more efficient

Featuring nine forward gears, this automatic transmission takes efficiency, comfort and dynamism to a completely new level. It is the new generation 9-speed automatic transmission with hydrodynamic torque converter in the premium segment. The larger ratio range allows a reduction in engine speed. Performance remains excellent while ride comfort is enhanced and noise levels are reduced. The reduced intervals between the gears lead to faster gear changes and enhanced spontaneity and agility. At the same time, the 9G-TRONIC transmission impresses with smooth, barely perceptible gear shifting like that of a continuously variable transmission. As the 9G-TRONIC transmission is able to skip individual gears, multiple downshifts are possible for fast and powerful sprints.



PRE-SAFE Sound

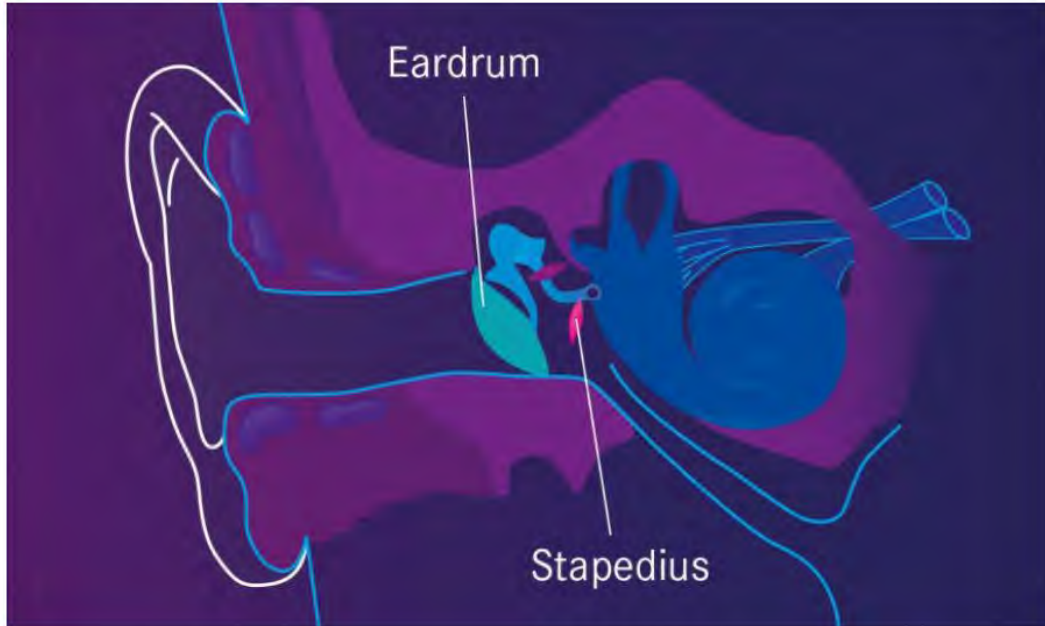

PRE-SAFE® Sound

Standard on all GLS models

Part of PRE-SAFE, PRE-SAFE Sound is an acoustic occupant preconditioning system which can reduce the effects of the noise from an accident on the occupants hearing.

- When the PRE-SAFE system recognizes a certain dangerous situation, the onboard sound system plays a brief rushing sound, also known as 'Pink Noise', to precondition the hearing
- The natural reflex mechanism of the stapedius muscle enables the inner ear to rapidly prepare for the accident-induced high pressure sound
- Up to 40% reduction of noise exposure impact





Active Brake Assist



Active Brake Assist (258)

Standard on all GLS models

- Radar-based driving assistance system that can help prevent accidents with vehicles ahead and with crossing pedestrians or mitigate the consequences of accidents
- Combination of proximity warning, collision warning, on-demand braking assistance and autonomous braking function
- Additional audible warning if the distance diminishes rapidly
- If the driver initiates emergency braking – if necessary – increase in braking pressure by the on-demand braking assistance
- Initiation of autonomous braking if the driver fails to react
- Visual and audible warning plus almost simultaneous emergency braking if an impending collision with a crossing pedestrian is detected

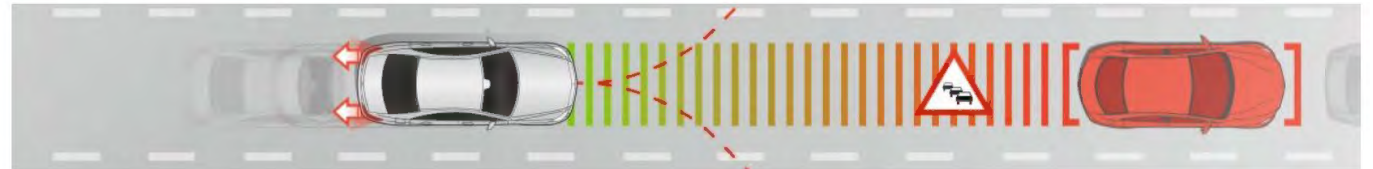
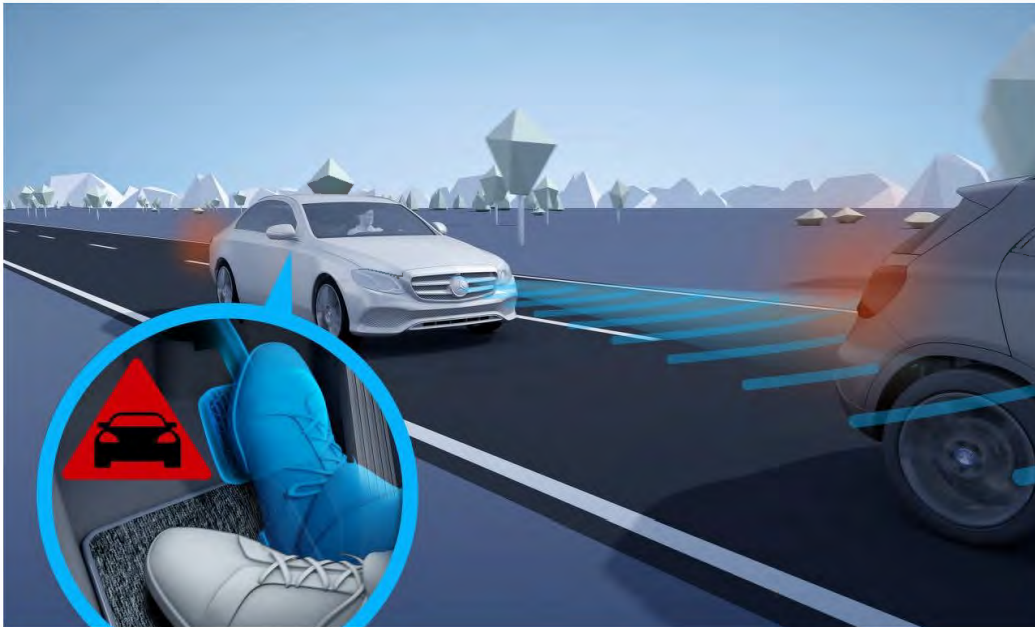



Driver Assistance Package Plus

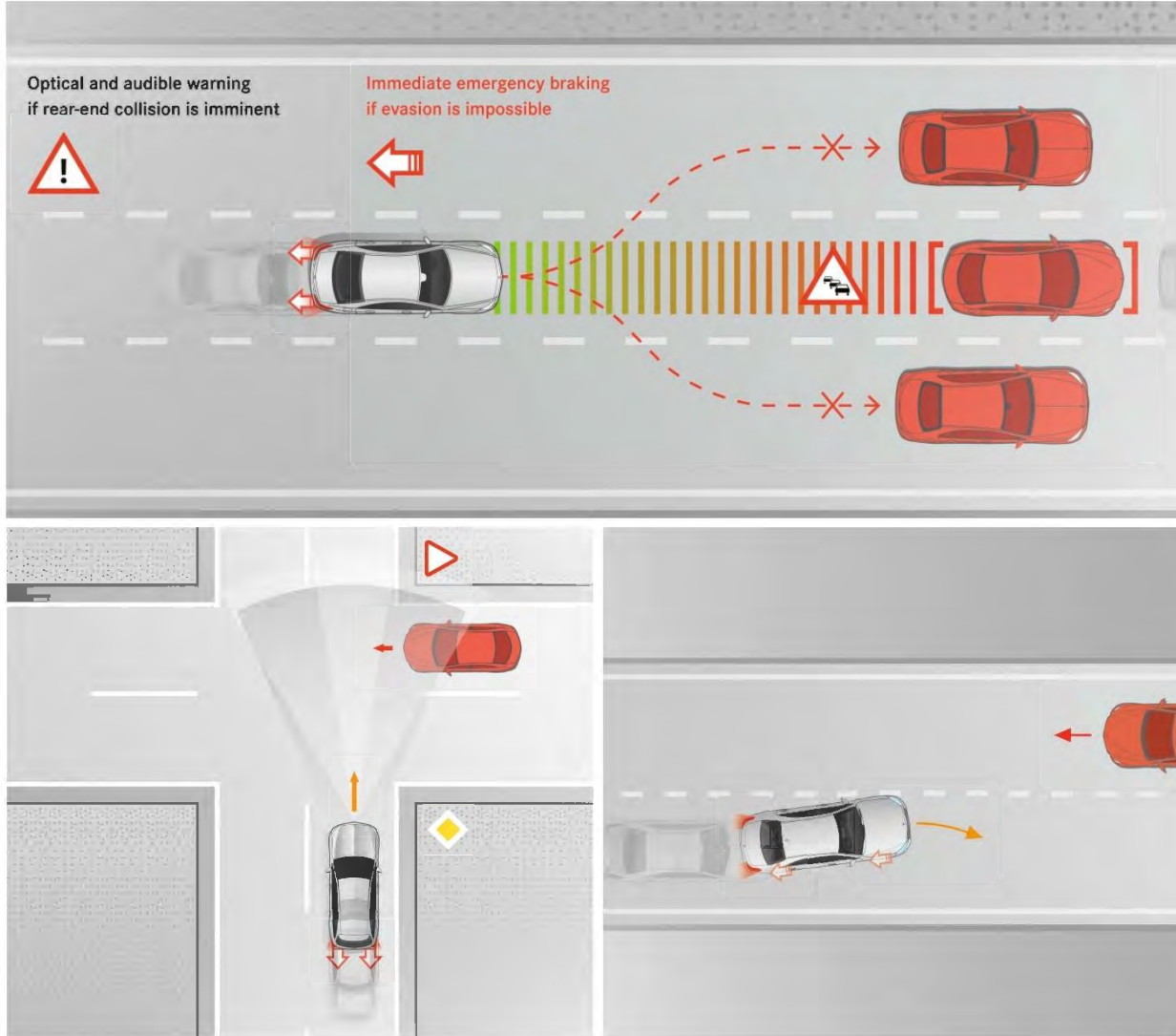

Driver Assistance Package Plus (DA2PKG)

Option price: \$2,250

Latest-generation of our Advanced Driver Assistance System: the enhanced intelligent hands-off detection includes sensing via the Touch Control Buttons and is sensitive to specific conditions and can be activated at a wide range of speeds.

- **Active Stop-and-Go Assist** see next slide
- **Active Distance Assist DISTRONIC®**
- **Active Steering Assist** can now actively intervene even if road lines are unclear or non-existent at certain speeds; it can now also function in curves with a tighter radius
- **Active Emergency Stop Assist** is able to brake the vehicle to a standstill in its lane if it detects that the driver is no longer actively driving the vehicle while it is on the move with Active Distance Assist DISTRONIC and Active Steering Assist engaged. It can now unlock the doors when the vehicle is stationary to allow first aid responders immediate access to the vehicle's interior
- **Active Lane Change Assist** is a radar-and-camera-based system that aids the driver when changing lanes. When a turn is indicated, this feature will aid with steering into the adjacent lane if it detects the lane is empty
- **Active Speed Limit Assist** can adapt vehicle speed to identified speed limits and can now adjust preemptively when speed limits are going to change.
- **Route-Based Speed Adaptation** is able to reduce the speed in anticipatory mode by referencing the vehicle's map data ahead of bends, junctions, roundabouts, toll booths and exit roads
- **Active Brake Assist with Cross-Traffic Function**
- **Evasive Steering Assist** this system assists by adding calculated steering torque to aid in steering wheel movement when a driver deliberately or instinctively performs an evasive maneuver around a pedestrian.
- **Active Blind Spot Assist** helps the driver to avoid an imminent side impact by sinGLS-sided braking.
- **Active Lane Keeping Assist**
- **PRE-SAFE® Impulse Side** see next slide



Driver Assistance Package Highlights

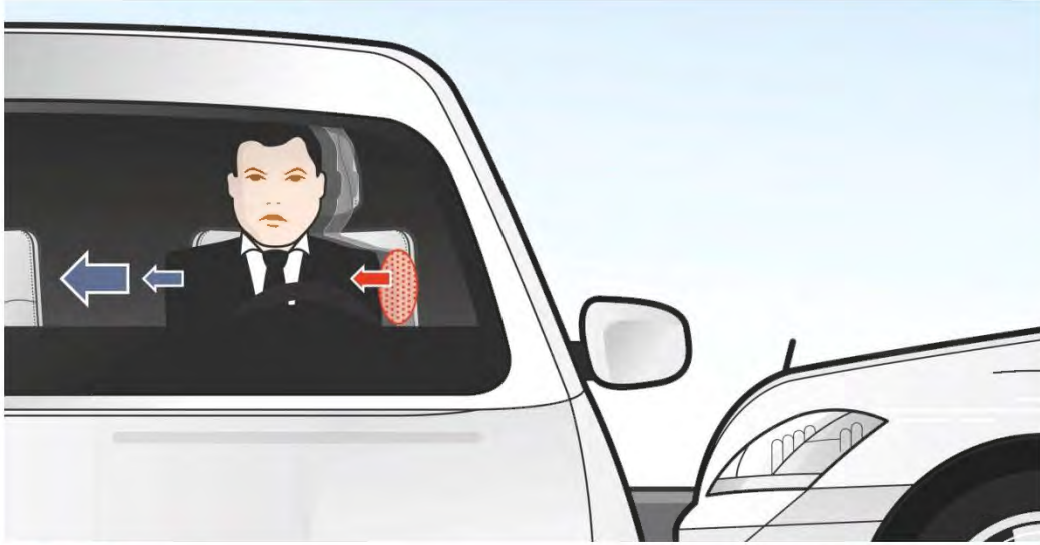

Mercedes-Benz Intelligent Drive – PRE-SAFE® Impulse Side

Included in Driver Assistance Package Plus (DA2PKG)

- PRE-SAFE® Impulse Side initiates preventative protective measures against an impending side impact, supplementing the measures taken by PRE-SAFE® and PRE-SAFE® PLUS
- In the event of a side impact, PRE-SAFE® Impulse Side can have a positive effect by increasing the distance between the occupant and the door, and at the same time reducing the relative speeds between the side structure and the occupant's torso
- In the event of a recognized, unavoidable side collision, the system can give the driver or front passenger a slight push towards the center of the vehicle on the side facing the impact
- This lateral impulse is initiated by very rapid inflation of an air chamber in the seat bolster



Mercedes-Benz Active Stop-and-Go Assist

Included in Driver Assistance Package Plus (DA2PKG)

- Enables the GLS to recognize traffic jams at an early stage, actively supporting the driver in stop-and-go traffic up to approx. 37 mph



LED Intelligent Light System w/ ULTRA WIDE Highbeams and Adaptive Highbeam Assist



LED Intelligent Light System w/ ULTRA WIDE Highbeams and Adaptive Highbeam Assist

Standard on all GLS models

- Active curve illumination
- ULTRA WIDE Highbeams produce light at an increased width for maximum illumination of the road and surround area
- Adaptive Highbeam Assist is also part of the LED Intelligent Light System and allows drivers to drive with activated main beams without dazzling other road users





Performance & Handling

- 9G-TRONIC 9-Speed Automatic Transmission
- AIRMATIC Suspension
- 19" MB wheels
- All Season Tires
- New 3.0L inline-6 turbo engine with EQ-Boost (362 hp, 369 lb-ft, EQ-Boost outputs 21 hp and up to 184 lb-ft) (GLS 450 4MATIC)
- 4.0L V8 Bi-turbo engine with EQ-Boost (483 hp, 516 lb-ft, EQ-Boost outputs 21 hp and up to 184 lb-ft) (GLS 580 4MATIC)

Comfort & Convenience

- KEYLESS-GO
- HANDS-FREE ACCESS
- Power Liftgate
- Remote Start
- LED Intelligent Light System
- Adaptive Highbeam Assist
- Power Tilt/Sliding Sunroof
- Multifunctional Steering Wheel with Touch Control Buttons
- Touchpad in Center Console
- MBUX User Interface incl. Voice Control with Natural Language Understanding
- 12.3" Digital Instrument Cluster
- 12.3" Media Display with Touchscreen
- Apple CarPlay and Android Auto
- 9 USBs (3 in front, 2 in 2nd row, 4 in 3rd row)
- HERMES Communications Module LTE
- MB Navigation with Live Traffic and Map Updates
- Ambient Lighting with 64 Colors and Illuminated Door Sills
- Heated Front Seats
- Power Front Seats with 4-Way Lumbar Support and Memory Function
- 2-Zone Climate control
- Concierge Service
- Garage door opener
- Load Compartment Cover
- Spare Tire
- Double Sun Visors
- Privacy Glass
- Mirror Package (power folding mirrors, auto-dimming driver and rearview mirrors, mirror logo projector)
- Roof Rails
- 115V household type power outlet
- Active Parking Assist with Surround View System
- Wireless Charging
- Burmester® Surround Sound System
- SiriusXM® Radio

Safety & Security

- ATTENTION ASSIST
- Blind Spot Assist
- PRE-SAFE®
- Active Brake Assist
- Emergency Call Service
- Car Exit Warning
- Anti-Theft Alarm System

Exterior Paint Colors



Non-metallic Paints



040U
Black
Option price: \$0



149U
Polar White
Option price: \$0

Metallic Paints



197U
Obsidian Black
Option price: \$720

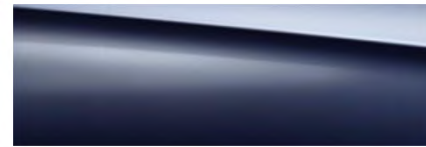

890U
Lunar Blue
Option price: \$720



775U
Iridium Silver
Option price: \$720



989U
Emerald Green
Option price: \$720



859U
Mojave Silver
Option price: \$720



896U
Brilliant Blue
Option price: \$720

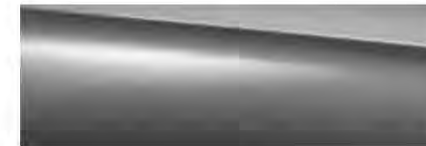

992U
Selenite Grey
Option price: \$720

designo[®] Paints



799U
Diamond White bright
Option price: \$1,515



996U
Cardinal Red metallic
Option price: \$1,080



65R
19" Twin 5-Spoke Wheels
R02, 690
Standard



94R
20" 8-Spoke Wheels
R02, 690
Option price: \$750



R33
20" Twin 5-Spoke Wheels
R02, 690
Option price: \$950



95R
21" Triplet 5-Spoke Wheels
R02, 690
Option price: \$1,750



R76
21" 5-Spoke Wheels
R02, 690
Option price: \$1,750

GLS 580 only



RWF
21" AMG Twin 5-Spoke Wheels
R02, 690
Option price: \$0



RWH
21" AMG 5-Spoke Wheels
w/ Black Accents
R02, 690
Option price: \$0
Requires Night Package (DC1PKG)



RPA
22" AMG Multi-Spoke Wheels
R01, 690
Option price: \$1,250



RPB
22" AMG Multi-Spoke Wheels
w/ Black Accents
R01, 690
Option price: \$1,250
Requires Night Package (DC1PKG)



RPQ
23" AMG Twin 5-Spoke Wheels
w/ Black Accents
R01, 690
Option price: \$2,950



<i>Code</i>	<i>Wheel Size</i>	<i>Description</i>	<i>Wheel Dimensions</i>		<i>Mobility</i>	<i>Availability</i>	<i>MSRP</i>
65R	19"	Twin 5-Spoke Wheels	275/55 R 19 on 8.5 J x 19 ET 62 275/55 R 19 on 8.5 J x 19 ET 62	(Front) (Rear)	R02, 690	GLS 450 only	\$ 0
94R	20"	8-Spoke Wheels	275/50 R 20 on 8.5 J x 20 ET 62.5 275/50 R 20 on 8.5 J x 20 ET 62.5	(Front) (Rear)	R02, 690	GLS 450 only	\$ 750
R33	20"	Twin 5-Spoke Wheels	275/50 R 20 on 8.5 J x 20 ET 62.5 275/50 R 20 on 8.5 J x 20 ET 62.5	(Front) (Rear)	R02, 690	GLS 450 only	\$ 750
95R	21"	Triplet 5-Spoke Wheels	275/45 R 21 on 10 J x 21 ET 62.5 315/40 R 21 on 11 J x 21 ET 55	(Front) (Rear)	R02, 690	GLS 450 only	\$ 1,750
R76	21"	5-Spoke Wheels	275/45 R 21 on 10 J x 21 ET 62.5 315/40 R 21 on 11 J x 21 ET 55	(Front) (Rear)	R02, 690	GLS 450 only	\$ 1,750
RWF	21"	AMG Twin 5-Spoke Wheels	275/45 R 21 on 10 J x 21 ET 44 315/40 R 21 on 11 J x 21 ET 42	(Front) (Rear)	R02, 690	GLS 580 only	\$ 0
RWH	21"	AMG Twin 5-Spoke Wheels w/ Black Accents	275/45 R 21 on 10 J x 21 ET 44 315/40 R 21 on 11 J x 21 ET 42	(Front) (Rear)	R01, 690	GLS 580 only	\$ 0 <i>Requires Night Package (DC1PKG)</i>
RPA	22"	AMG Multi-Spoke Wheels	285/45 R 22 on 9.5 J x 22 ET 45 325/40 R 22 on 11.5 J x 22 ET 47	(Front) (Rear)	R01, 690	GLS 580 only	\$ 1,250
RPB	22"	AMG Multi-Spoke Wheels w/ Black Accents	285/45 R 22 on 9.5 J x 22 ET 45 325/40 R 22 on 11.5 J x 22 ET 47	(Front) (Rear)	R01, 690	GLS 580 only	\$ 1,250 <i>Requires Night Package (DC1PKG)</i>
RPQ	23"	AMG Twin 5-Spoke Wheels w/ Black Accents	285/40 R 23 on 9.5 J x 23 ET 45 325/35 R 23 on 11.5 J x 23 ET 47	(Front) (Rear)	R01, 690	GLS 580 only	\$ 2,750



111A
Black
Option price: \$0



114A
Espresso Brown
Option price: \$0



115A
Macchiato Beige/Magma Grey
Option price: \$0

MB-Tex not with Multicontour Seats (399)



201A*
Black
Option price: \$1,620



204A*
Espresso Brown/Magma Grey
Option price: \$1,620



205A
Macchiato Beige/Magma Grey
Option price: \$1,620



284A*
Black/Tartufo
Option price: \$1,620

Interior Upholstery – Exclusive Nappa Leather



958A

Black/Magma Grey Exclusive Nappa leather

Option price: \$2,990 (GLS 450)/\$1,370 (GLS 580)





<i>Code</i>	<i>Upholstery</i>	<i>Seats</i>	<i>Floor Mats</i>	<i>Upper Dash/Lower Dash</i>	<i>Seat Belts</i>	<i>Steering Wheel</i>	<i>Headliner</i>
111A	Black MB-Tex	Black	Black	Black/Black	Black	Black	Crystal Grey or Black
114A	Espresso Brown MB-Tex	Espresso Brown	Magma Grey	Magma Grey/Espresso Brown	Magma Grey	Magma Grey	Crystal Grey
115A	Macchiato Beige/Magma Grey MB-Tex	Macchiato Beige	Magma Grey	Magma Grey/Macchiato Beige	Macchiato Beige	Magma Grey	Macchiato Beige
201A	Black leather	Black	Black	Black/Black	Black	Black	Crystal Grey or Black
204A	Espresso Brown/Magma Grey leather	Espresso Brown	Magma Grey	Magma Grey/Espresso Brown	Magma Grey	Magma Grey	Crystal Grey or Black
205A	Macchiato Beige/Magma Grey leather	Macchiato Beige	Magma Grey	Magma Grey/Macchiato Beige	Macchiato Beige	Magma Grey	Macchiato Beige
284A	Black/Tartufo leather	Tartufo	Black	Black/Black	Black	Black	Crystal Grey or Black
958A	Black/Magma Grey Exclusive Nappa leather	Magma Grey	Black	Magma Grey/Magma Grey (with U38) or Black/Black (with U09)	Magma Grey	Black	Crystal Grey or Black

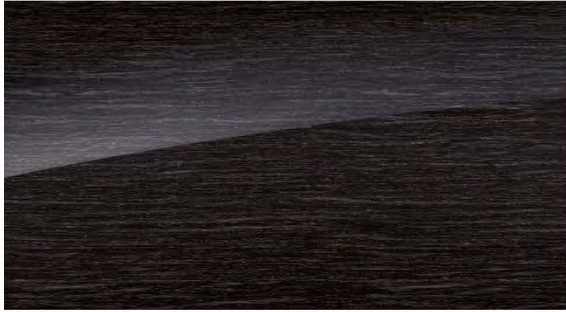

H18
Grey Linden Wood
Standard



H22
Natural Grain Brown Walnut Wood
Option price: \$160



H31
Natural Grain Grey Oak Wood
Option price: \$160

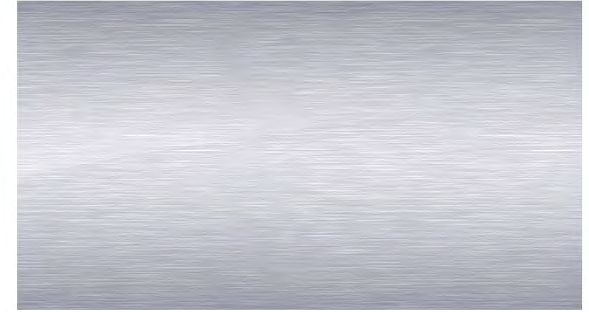

H46
Aluminum (longitudinal grain)
Option price: \$0

Available as of 01/2020 Production

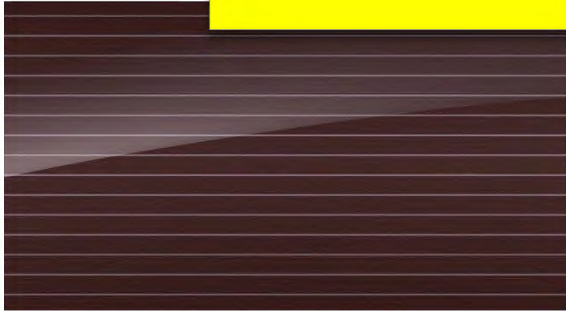

H34
designo® Brown Linden 'Flowing Lines'
Wood
Option price: \$850

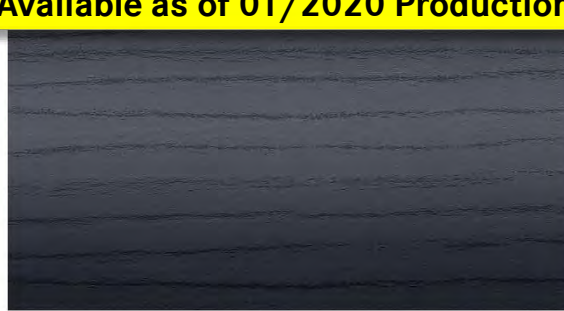

H35
designo® Black Flamed Natural Grain Ash
Wood
Option price: \$850

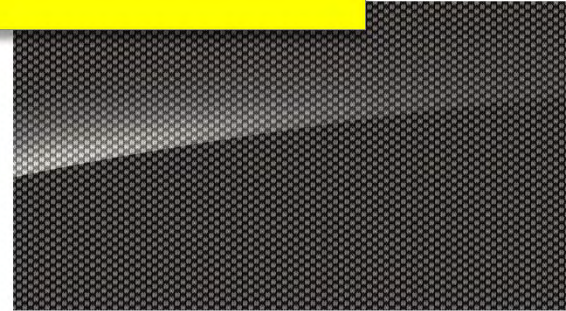

H64
Metal Weave
Option price: \$600



<i>Code</i>	<i>Packages</i>	<i>Availability</i>	<i>MSRP</i>
DA1PKG	Convenience Package <ul style="list-style-type: none"> ▪ 581 – 4-Zone Climate Control ▪ 401 – Heated and Ventilated Front Seats ▪ 297 – Electric Rear Side-Window Sunshades 	Available on GLS 450	\$ 1,750
DA2PKG	Driver Assistance Package Plus <i>Requires Multicontour Front Seats (399)</i> P20 – Driver Assistance Package Plus <ul style="list-style-type: none"> ▪ Active Stop-and-Go Assist ▪ 233 – Active Distance Assist DISTRONIC ▪ 266 – Active Steering Assist ▪ Active Emergency Stop Assist ▪ Active Lane Change Assist ▪ 546 - Active Speed Limit Assist ▪ Route-Based Speed Adaptation ▪ Active Brake Assist with cross-traffic function ▪ Evasive Steering Assist ▪ Active Blind Spot Assist ▪ Active Lane Keeping Assist ▪ 253 - PRE-SAFE® PLUS with rear-end collision protection ▪ 292 – PRE-SAFE® Impulse Side ▪ 513 – Traffic Sign Assist 	All Models	\$ 2,250
DA9PKG	Off-Road Package <ul style="list-style-type: none"> ▪ 430 – Off-Road Package ▪ 481 – Underguard 	Available on GLS 580	\$ 1,900



<i>Code</i>	<i>Packages</i>	<i>Availability</i>	<i>MSRP</i>
DB0PKG	Warmth and Comfort Package <ul style="list-style-type: none"> ▪ P69 – Warmth and Comfort Package <ul style="list-style-type: none"> ▪ 906 – Heated Armrest ▪ 907 – Heated Armrest in the Rear ▪ 902 – Rapid Heating Seats 	All Models	\$ 1,050
DB5PKG	Executive Rear Seat Package <i>Only in combination w/ 7 Seater Configuration (226)</i> <ul style="list-style-type: none"> ▪ P11 – Executive Rear Seat Package <ul style="list-style-type: none"> ▪ 437 – Comfort Headrests in the Rear ▪ 898 – Wireless Charging in the Rear ▪ 447 – MBUX Rear Tablet ▪ 293 – Sidebags in the Rear 	All Models	\$ 2200
DB6PKG	Executive Rear Seat Package Plus <i>Not w/ Executive Rear Seat Package (DB5PKG)</i> <i>Only in combination w/ 7 Seater Configuration (226)</i> <i>Requires Heated and Ventilated Seats (401)</i> <ul style="list-style-type: none"> ▪ P11 – Executive Rear Seat Package ▪ 402 – Heated and Ventilated Seats in the Rear ▪ 406 – Multicontour Seats in the Rear w/ massage function 	All Models	\$ 4400
DB8PKG	ENERGIZING Package Plus <i>Requires Warmth and Comfort Package (DB0PKG)</i> <ul style="list-style-type: none"> ▪ P21 – AIR-BALANCE Package with fragrance ▪ 401 – Heated and ventilated Front Seats ▪ 399 – Active Multicontour Front Seats w/ massage function 	All Models	\$ 2,100



<i>Code</i>	<i>Packages</i>	<i>Availability</i>	<i>MSRP</i>
DC1PKG	Night Package <ul style="list-style-type: none"> ▪ P55 – Night Package <ul style="list-style-type: none"> ▪ High-gloss black elements: louvre in radiator grille, front apron trim strip, simulated underguard, rear apron trim strip, side mirrors, window line trim strip, beltline trim strip ▪ Matte black elements: roof rails ▪ Wheel choice of: <ul style="list-style-type: none"> • RWH – 21" AMG 5-Spoke Wheels w/ Black Accents • RPB – 22" AMG Multispoke Wheels w/ Black Accents (+ \$1,250) 	Available on GLS 580	\$ 400
DC5PKG	Acoustic Comfort Package <ul style="list-style-type: none"> ▪ PAF – Acoustic Comfort Package <ul style="list-style-type: none"> ▪ Increased cabin insulation, windshield and side windows with acoustic and heat absorbing membrane ▪ Infrared-reflecting glass 	All Models	\$ 1,100
DC7PKG	E-ACTIVE BODY CONTROL Package <ul style="list-style-type: none"> ▪ 490 – E-ACTIVE BODY CONTROL ▪ 481 – Underguard 	All Models	\$ 6,500

Stand-Alone Options



<i>Code</i>	<i>Options</i>	<i>Availability</i>	<i>MSRP</i>
243	Active Lane Keeping Assist <i>Not w/ Driver Assistance Package Plus (DA2PKG)</i>	All Models	\$ 550
297	Electric Rear Side-Window Sunshades <i>Available in Convenience Package (DA1PKG) for GLS 450</i>	Available on GLS 580	\$ 380
307	Heated/Cooled Cup Holder in Rear <i>Requires Executive Rear Seat Package (DA5PKG) or Executive Rear Seat Package Plus (DA6PKG)</i>	All Models	\$ 180
311	Heated/Cooled Cup Holders	All Models	\$ 180
399	Active Multicontour Front Seats with Massage Function <i>Requires Heated and Ventilated Front Seats (401) Requires Rapid Heating Seats (902) or Warmth and Comfort Package (DB0PKG) Requires Leather or Nappa Leather upholsteries</i>	Available on GLS 450 Standard on GLS 580	\$ 1,100
401	Heated and Ventilated Front Seats	Available on GLS 450 Standard on GLS 580	\$ 450
413	Panorama Sliding Sunroof	All Models	\$ 1,000
443	Steering Wheel Heating <i>Only w/ round steering wheels L3B or L3D</i>	All Models	\$ 250
463	Head-Up Display	All Models	\$ 1,100
513	Traffic Sign Assist	All Models	\$ 295
550	Trailer Hitch <i>Includes Increased Towing Capacity (557); Please note: no accessory retrofit available</i>	All Models	\$ 575
581	4-Zone Climate Control	Available on GLS 450	\$ 860
582	5-Zone Climate Control <i>Requires 4-Zone Climate Control (581)</i>	Available on GLS 450 Standard on GLS 580	\$ 400
735	Exclusive Trim Package <i>Not w/ Aluminum (H46) or Metal Weave (H64) Trim</i>	All Models	\$ TBD

Stand-Alone Options



<i>Code</i>	<i>Options</i>	<i>Availability</i>	<i>MSRP</i>
811	Burmester® High-End 3D Surround Sound System <i>Not with MBUX Interior Assistant (77B)</i>	All Models	\$ 4,550
846	Illuminated Running Boards <i>Please note: no accessory retrofit available</i>	Available on GLS 450 Standard on GLS 580	\$ 650
872	Heated Rear Seats	All Models	\$ 580
874	MAGIC VISION CONTROL <i>incl. Heated Windscreen Washer System</i>	All Models	\$ 350
883	Soft Close Doors	Available on GLS 450 Standard on GLS 580	\$ 550
886	Heated 3rd Row Seats <i>Requires Heated Rear Seats (872) or Heated and Ventilated Front Seats (402)</i> <i>Requires 5-Zone Climate Control (582) - restriction is valid until Dec 2019 -</i>	All Models	\$ 360
61U	Headliner DINAMICA black <i>Not available with upholstery 115A or 205A</i>	All Models	\$ 1,600
77B	MBUX Interior Assistant (Gesture Control) <i>Not w/ Burmester® High-End 3D Surround Sound System (811)</i>	All Models	\$ 300
L3D	Wood/Leather Multifunction Steering Wheel <i>Requires Natural Grain Brown Walnut Wood Trim (H22) or Natural Grain Grey Oak Wood Trim (H31) or designo® Brown Linden 'Flowing Lines' Wood Trim (H34)</i>	All Models	\$ 600
P21	AIR-BALANCE Package with Fragrance	All Models	\$ 350
U09	Lower Dashboard & Door Beltlines in MB-Tex	All Models	\$ 350
U19	MBUX Augmented Reality for Navigation	All Models	\$ 300
U38	Dashboard & Door Beltlines in Nappa Leather <i>Requires Black / Magma Grey Exclusive Nappa Leather (958A)</i>	All Models	\$ 1,050

Stand-Alone Options



<i>Code</i>	<i>VPC Installed Accessories</i>	<i>Availability</i>	<i>MSRP</i>
D03	Illuminated Star <i>Not available with Driver Assistance Package Plus (DA2PKG)</i>	All Models	\$ tbd
D08	Chrome Door Handle Inserts	All Models	\$ tbd
D11	Roof Spoiler	All Models	\$ tbd
D24	Black Side Cladding	All Models	\$ tbd
D25	USB-C Adapter Cable	All Models	\$ tbd
D26	Load Sill Protector	All Models	\$ tbd
D27	Wheel Locking Bolts, Silver	All Models	\$ tbd



Steering Wheel



Nappa Leather Multifunction Steering Wheel (L3B)

Standard on GLS 450

- Newly redesigned 3-spoke multifunction steering wheel in nappa leather
- Touch control buttons for direct control of the instrument cluster and to control the functions of the multimedia system
- Bezel and buttons in silver chrome
- Panels in high-gloss black
- Shift paddles in black



Wood/Leather Multifunction Steering Wheel (L3D)

Option Price: \$600

Requires trim H22 or H31 or H34

- Newly redesigned 3-spoke multifunction steering wheel in wood/leather
- Touch control buttons for direct control of the instrument cluster and to control the functions of the multimedia system
- Bezel and buttons in silver chrome
- Panels in high-gloss black
- Shift paddles in black



Nappa Leather Multifunction Sport Steering Wheel (L5C)

Standard on GLS 580

Not with Steering Wheel Heating (443)

- Newly redesigned 3-spoke multifunction sport steering wheel in nappa leather with flattened bottom section and perforated grip area
- Touch control buttons for direct control of the instrument cluster and to control the functions of the multimedia system
- Bezel, panels and buttons in silver chrome
- Shift paddles in silver chrome



Steering Wheel Heating (443)

Option Price: \$250

- On cold days, the heated 3-spoke steering wheel rim very quickly warms the grip area of the steering wheel to ensure pleasantly warm hands.
- The function is switched on and off by turning the control lever for adjusting the multifunction steering wheel.



Burmester® Surround Sound Systems



Burmester® Surround Sound System (810)

Standard

- 13 high-performance speakers precisely configured for the vehicle interior to ensure well-balanced and very dynamic music reproduction
- 9-channel DSP amplifier with a total output of 590 watts (7 x 50 W and 2 x 120 W) for maximum sound quality with very high volume reserves
- Frontbass® technology with woofers integrated into the body-in-white
- Sound optimization for the front and rear seats
- Vehicle noise compensation (VNC)
- Sound preset: surround function to generate virtual all-round sound
- Support for popular multi-channel formats for true surround sound



Burmester® High-End 3D Surround Sound System (811)

Option Price \$5,400

Not with MBUX Interior Assistant (77B), AMG Line Exterior (DG1)

- 26 high-end speakers including subwoofer and speaker units in the roof liner
- 27-channel amplifier with digital and active analogue filters and an output of 1,210 watts plus an additional subwoofer booster amplifier delivering 400 watts (total system output 1,610 watts)
- VIP seat function to optimize the sound for individual seats
- Mid-range, low- to mid-range and Frontbass speakers with membranes made of glass-fibre fabric
- Noise compensation (VNC) for dynamic equalizing
- Supports multichannel audio formats



Exclusive Trim Package (735)



Exclusive Trim Package (735)

Option Price: TBD

The Trim package lends your interior an individual look. Additional trim elements on the back of the front seat backrests blend seamlessly into the interior, creating some exciting contrasts. The rear seat passengers in particular can enjoy an enhanced sense of high-class appeal.

- **Additional trim elements on the back of the front seat backrests – optionally in:**
 - Grey Linden Wood (H18)
 - Natural Grain Brown Walnut Wood (H22)
 - Natural Grain Grey Oak Wood (H31)
 - *designo* Brown Linden 'Flowing Lines' Wood (H34)
 - *designo* Black Flamed Natural Grain Ash Wood (H35)

- **Map pockets in ARTICO man-made leather**



Black Side Claddings (D11)



Black Side Claddings (D24)

Option price: TBD

- New GLS side cladding highlights new GLS side lines
- Side cladding protects vehicle from unwanted contacts
- Matt black surface
- New design feature adding an individual look to light colored customer vehicles
- Covers front an rear doors

European picture shown – wheels n/a in US



Roof Spoiler (D11)



Roof Spoiler (D11)

Option price: TBD

The roof spoiler (painted in the vehicle color) gives the rear of the vehicle a more dynamic and sporty look. Does not affect field of vision in rear-view mirror.



	<i>GLS 450 4MATIC</i>	<i>GLS 580 4MATIC</i>
Engine Configuration	3.0L In-line-6 Turbo Engine with EQ-Boost	4.0L V8 Bi-Turbo Engine with EQ-Boost
Power (hp)	362	483
Electric motor (hp), System output (hp)	21	21
Torque (lb-ft)	369	516
Electric Motor (lb-ft), System Torque (lb-ft)	184	184
Displacement (cc)	2,999	3,982
Acceleration 0-60 mph (sec)	5.9	5.2
Fuel Economy (Cty/Hwy/Comb)	Tbd	Tbd
Top Speed (mph)	130	130
Fuel Requirement (Octane)	91	91
Compression	10.5 : 1	10.5:1
Transmission	9G-TRONIC 9-Speed Automatic Transmission	9G-TRONIC 9-Speed Automatic Transmission
Transmission Speeds	9	9
Drive Configuration	All-wheel drive	All-wheel drive
Fuel Tank Size (gallons)	23.8	23.8
Trunk Size (cubic feet)	48.7	48.7
Curb Weight (lbs)	Tbd	Tbd
Maximum Load (lbs)	Tbd	Tbd
Vehicle Length (in.)	205.0	205.2
Vehicle Width w/ exterior mirrors (in.)	84.9	84.9
Vehicle Height (in.)	71.8	71.8
Wheelbase (in.)	123.4	123.4
Track Width Front/Rear (in.)	65.7/66.6	67.1/68.2
Towing Capacity (lbs)	7,700	7,700

Specifications* – GLS 450 4MATIC

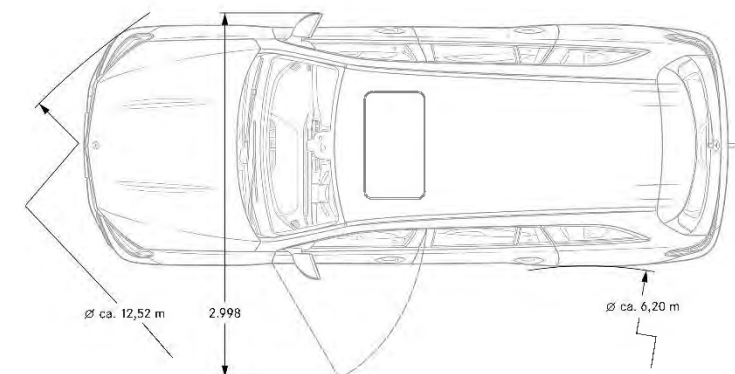
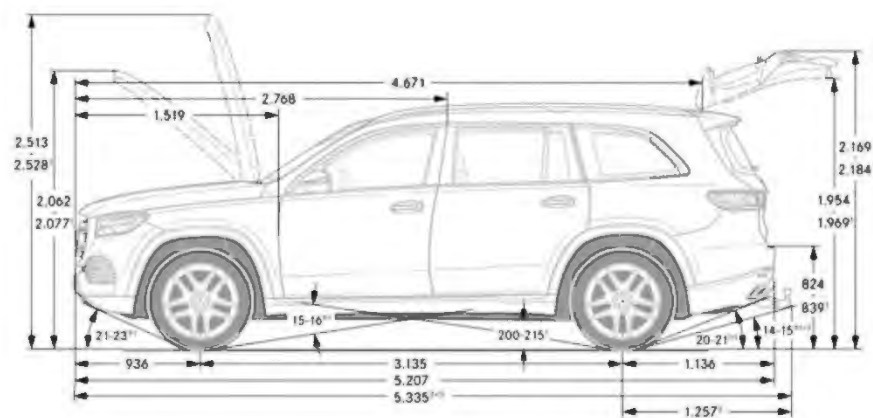
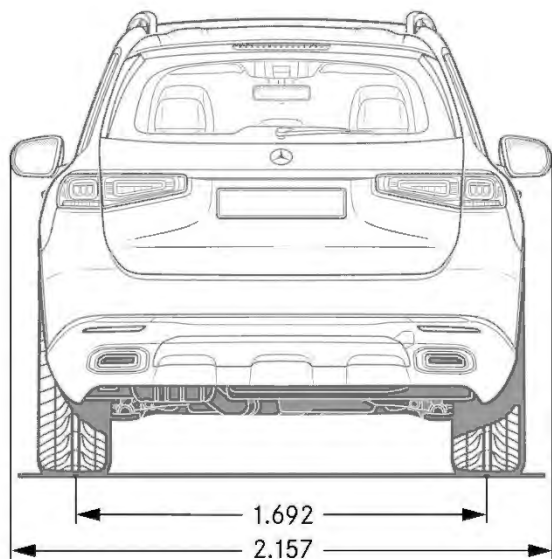
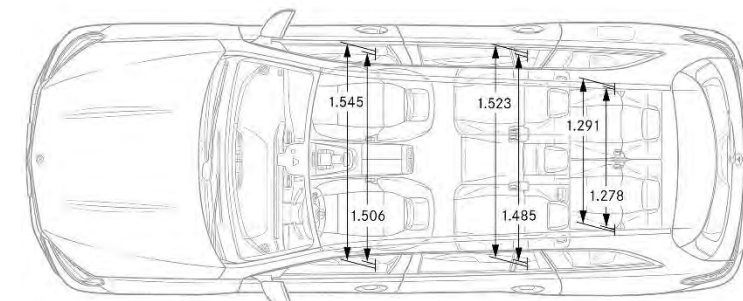
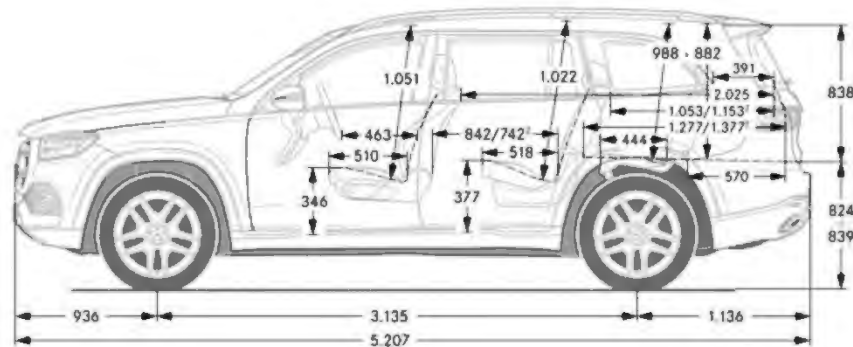
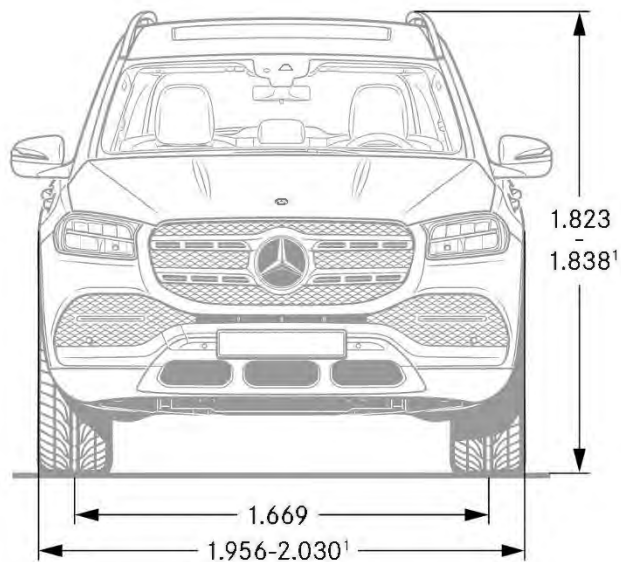

Specifications* – GLS 580 4MATIC

