

# GLS SUV



X167

Model Year 2020

*Preliminary – Subject to Change*

Mercedes-Benz

The best or nothing.





## *Important note*

The information presented in this guide is based on the most current information available and is intended for internal use only. Mercedes-Benz reserves the right to make changes at any time, without notice, to colors, materials, equipment, special specifications and models.

Pricing may not yet be finalized for some models or options.

Due to variances among monitors and printers the colors that appear on your screen and printouts may not be exact.

For illustrative purposes, some images may show vehicles with European Specification.

## *Revision History*

<i>Date</i>	<i>Changes</i>
04/17/2019	All-new model initial release – prices subject to change
04/24/2019	Removed restriction on 958 interior. Added Off-Road Package (DA9PKG) for GLS 580
07/18/2019	Minor layout adjustments; added additional equipment descriptions
08/08/2019	Dissolved Off-Road Package (DA9PKG) to stand-alone options Off-Road Package (430) and Underguard (481)
08/19/2019	Updated availability of upholstery 284 (from March 2020)
09/09/2019	21" Wheel RWF as standard for GLS 580
09/11/2019	Added Sport Brake System (U28) as Special Order Option
09/19/2019	Added R01 as Special Order Option



## *GLS 450 4MATIC & GLS 580 4MATIC*



Models



What's new



Standard Equipment



Exterior Paint Colors



Wheels



Interior Upholstery



Interior Trims



Option Packages



Stand-Alone Options



Options in Detail



Specifications



*GLS 450 4MATIC (167.959)*

- MSRP \$ 75,200
- 3.0L Inline-6 Turbo Engine with EQ-Boost
- Horsepower 362 hp
- Torque 369 lb-ft
- EQ Boost Outputs 21 hp and up to 184 lb-ft
- 5.9 sec est. (0-60 mph)
- Launch date: Q3/2019 (MY20)



*GLS 580 4MATIC (167.986)*

- MSRP \$97,800
- 4.0L V8 Bi-Turbo Engine with EQ-Boost
- Horsepower 483 hp
- Torque 516 lb-ft
- EQ Boost Outputs 21 hp and up to 184 lb-ft
- 5.2 sec est. (0-60 mph)
- Launch date: Q4/2019 (MY20)

Pictures show European Model



## *Exterior Comparison MY19 (X166) vs. MY20 (X167)*



European picture shown



## *Exterior Comparison GLS 450 4MATIC vs. GLS 580 4MATIC*



**GLS 450 4MATIC**



**GLS 580 4MATIC**

*Interior Comparison MY19 (X166) vs. MY20 (X167)*



MY19



MY20



Picture shows optional Equipment

Picture shows optional Equipment



## *Interior Comparison GLS 450 4MATIC vs. GLS 580 4MATIC*



**GLS 450 4MATIC**



**GLS 580 4MATIC**





## *Interior Highlights*



Two dominant grab handles on the center console



Enlarged panoramic sliding sunroof with 50% larger viewing area



Trims w/ new matching center console

New generation steering wheels with touch buttons



Ambient lighting with 64 colors

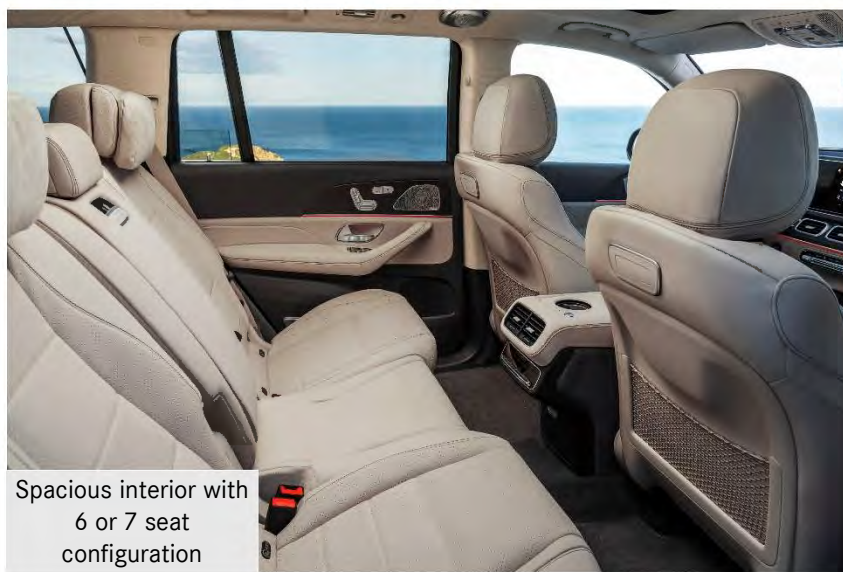

Spacious interior with 6 or 7 seat configuration



MBUX

New air vent design



## Exterior

- Greater length, width, wheelbase and track width
- Emotional and dynamic design
- Hood with two prominent power domes
- Free-standing roof rails in chrome finish
- Dark wheel arch claddings
- New: large 19-23" wheels
- Distinguished, chrome underride guard in SUV-specific design
- New exterior paint colors

## Interior

- Progressive all-new SUV interior design
- New generation steering wheels with touch control buttons
- Instrument panel and center console visually divided and redesigned
- Trim elements with open-pore woods
- Two dominant grab handles on the center console
- SUV-specific storage compartments

## Standard Equipment

- LED Intelligent Light System
- MBUX User Interface incl. Voice Control with Natural Language Understanding
- MB Navigation
- 12.3" Digital Instrument Cluster
- 12.3" Media Display with Touchscreen
- 6 or 7 Seat Configuration
- Ambient Lighting with 64 Colors and Illuminated Door Sills
- Active Parking Assist with Surround View
- Memory Function for Passenger Seat
- 115V Household Type Power Outlet
- Touchpad in Center Console
- 9 USBs Type-C (3 in front, 2 in 2<sup>nd</sup> row, 4 in 3<sup>rd</sup> row)
- Blind Spot Assist
- Wireless Charging
- Burmester® Surround Sound
- SiriusXM® Radio
- KEYLESS-GO
- HANDS-FREE ACCESS
- Automatic Car Wash Mode

## Optional Equipment

- AIR-BALANCE Package (P21)
- Head-Up Display (463)
- E-ACTIVE BODY CONTROL Package (DC7PKG)
- 4/5-Zone Climate Control (581/582)
- Enlarged panoramic sliding sunroof with 50% larger viewing area (413)
- Illuminated running boards with robust stainless-steel inserts (846)
- Executive Rear Seat Package/Executive Rear Seat Package Plus (DB5PKG/DB6PKG)
- MBUX Interior Assistant (Gesture Control) (77B)
- MBUX Augmented Reality for Navigation (U19)



## MY 20 GLS Seating Choices

No additional Pricing.

### **7 Seat Configuration (226)**

2 + 3 + 2 Seats

*Required for Executive Rear Seat Package (DB5PKG)  
and Executive Rear Seat Package Plus (DB6PKG)*

or

### **6 Seat Configuration (224)**

2 + 2 + 2 Seats

*Individual Seats with Armrests in 2<sup>nd</sup> row*

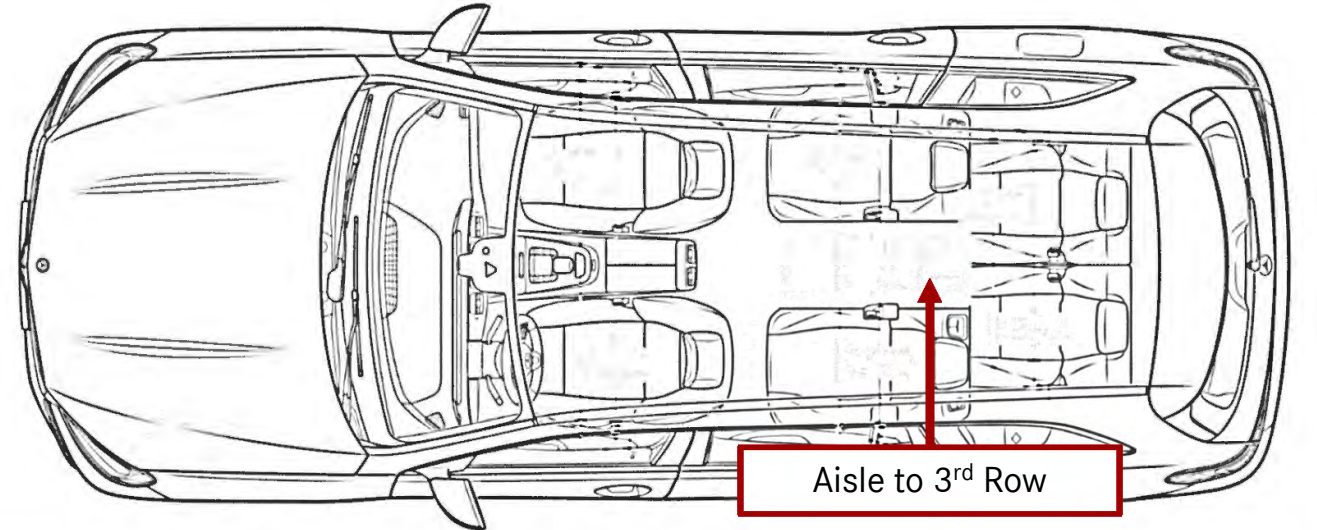
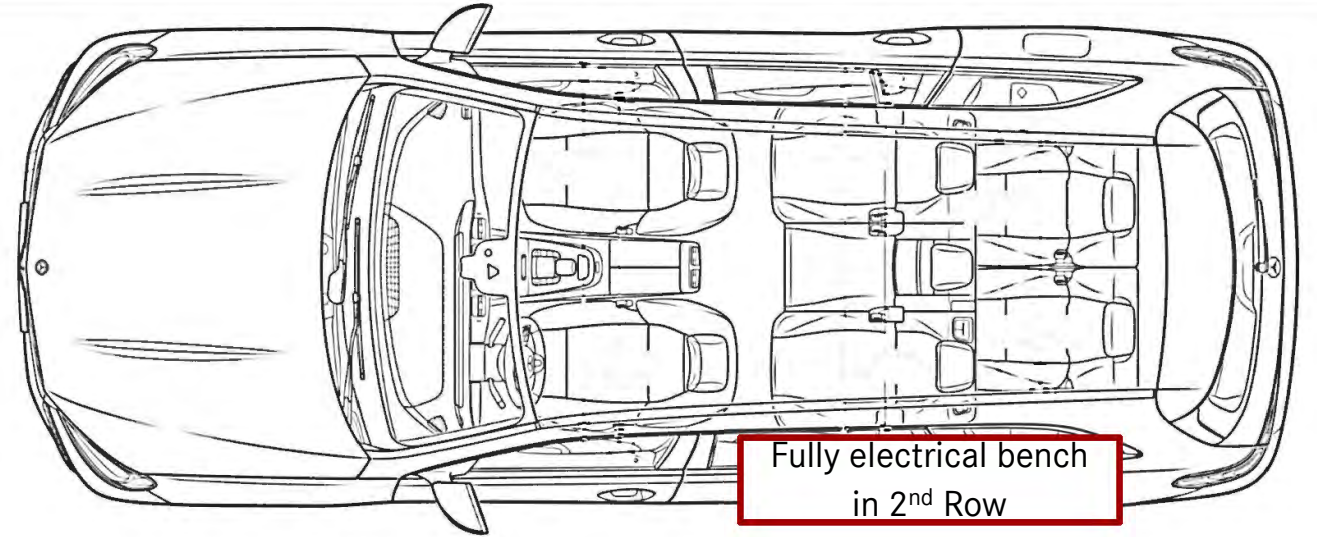



## Mercedes-Benz User Experience (MBUX)

### MBUX - the newest head unit generation from Mercedes-Benz

*Standard on all GLS models*

- Offered with two 12.3" digital displays as standard equipment
- MBUX was designed for a touch interface with intuitive operation
- There are four ways of interacting with the system:
  - An all-new Touchpad, Touch Control Buttons on the steering wheel, a touchscreen center display, and an all-new generation of Voice Control
- Multiple users can set up Profiles which save their settings for future use
  - Including: seat settings, music preferences and radio settings, phone settings, themes/moods, Bluetooth connections, etc.
- Over time, the system learns more about it's owners and creates Suggestions based on past behavior of the user
- Whole groups of settings can be saved together in the form of a Theme/Mood
  - Including: ambient lighting, climate control, music preferences, and setup of the Digital Instrument Cluster and head unit display, etc.
- Using over-the-air updates, MBUX can continuously be improved over time
- The system is very quick and responsive due to it's impressive graphics processing and computing power

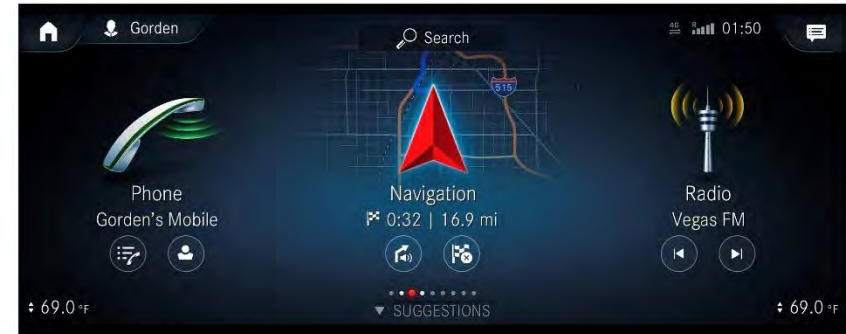

## Voice Control

### The most advanced Voice Control in any Mercedes-Benz vehicle

Standard on all GLS models

- Voice Control with MBUX is greatly enhanced over other systems by using both an onboard and offboard system for voice recognition
  - This ensures quick and appropriate responses
- The system also uses Natural Language Understanding so there's no need to remember the order of words for a specific command, just talk to the voice assistant as you would speak to another person
  - There are many ways of saying the same thing: *"Take me to Starbucks"*, or *"Find a Starbucks nearby"*, or *"Is there a Starbucks close?"*, or even *"I need a coffee"*
- Indirect commands can also be given like *"Will I need an umbrella today?"* and the Voice Control system understands that the user is really asking whether it will rain today
- In-vehicle components can also be controlled via Voice Control, like seat heating, climate control, ambient lighting, massage programs, and even the sunshade for the Panorama roof
- Voice Control is also capable of learning from its users and adjusting its understanding to their specific way of speaking
- Keyword Activation ensures you can quickly interact with Voice Control without having to press the button on the steering wheel
  - The system wakes up with a simple *"Hey Mercedes"* or *"Hi Mercedes"*

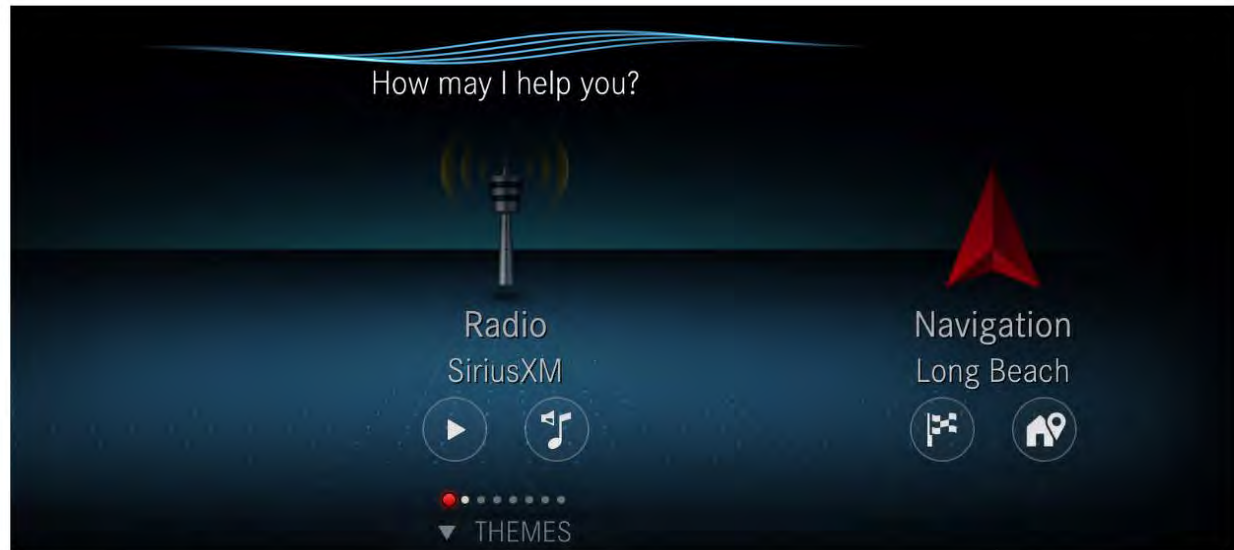



## Steering Wheel



### **3-Spoke Nappa Leather Multifunction Steering Wheel (L3B)**

*Standard on all GLS models*

The newly redesigned 3-spoke multifunction steering wheel in nappa leather combines a sporty design, compact dimensions and fine materials.

- Steering wheel shift paddles integrated into the back of the steering wheel cross spokes enable manual gear shifting and support a sporty driving style
- Steering wheel shift paddles in the steering wheel color
- Optional Active Distance Assist DISTRONIC® or standard cruise control is controlled via steering wheel-mounted controls
- Touch Control buttons for direct control of the instrument cluster and to control the functions of the multimedia system



## Touchpad Controller



### **Touchpad Controller (448)**

*Standard on all GLS models*

The functions of MBUX can be controlled intuitively via the innovative touchpad, using single or multi-finger gestures (multi-touch):

- Touchpad approx. 3.35 x 3.54 inches in size
- Additional full-fledged input option supplementing the central controller, Touch Control Buttons on the steering wheel and voice control
- Recognizes single or multi-finger gestures (multi-touch), swiping movements and zoom gestures achieved by spreading the fingers or pinching them together
- Innovative handwriting recognition feature: Users are able to input letters, special characters and numbers in their normal handwriting, in any language available in the headunit
- 3 buttons located on the touchpad allow fast and direct operation of important functions
- Clear haptic feedback when using the touchpad or keys



## Ambient Lighting with 64 Colors



### **Ambient Lighting with 64 Colors (876)**

*Standard on all GLS models*

Showcase the interior according to your personal preferences or current mood. With a total of 64 colors, the ambient lighting gives you almost unlimited scope for lighting schemes, and has the right color available for any situation. Additional light elements in white help to ensure good orientation.

- All colors can be individually selected
- Brightness of the illumination zones can be freely selected between 0 and 100%
- Nine color schemes with different color combinations are pre-programmed
- Dynamic mode: atmospheric color changes thanks to slow, seamless transition between different colors
- Climate effect: feedback in color when changing the temperature setting
- Welcome effect: special light display when getting into the vehicle
- Incorporation of ambient lighting into the programs of the ENERGIZING comfort control, in conjunction with ENERGIZING package Plus
- Illuminated door sill panels with “Mercedes-Benz” lettering





## *PRE-SAFE Sound*

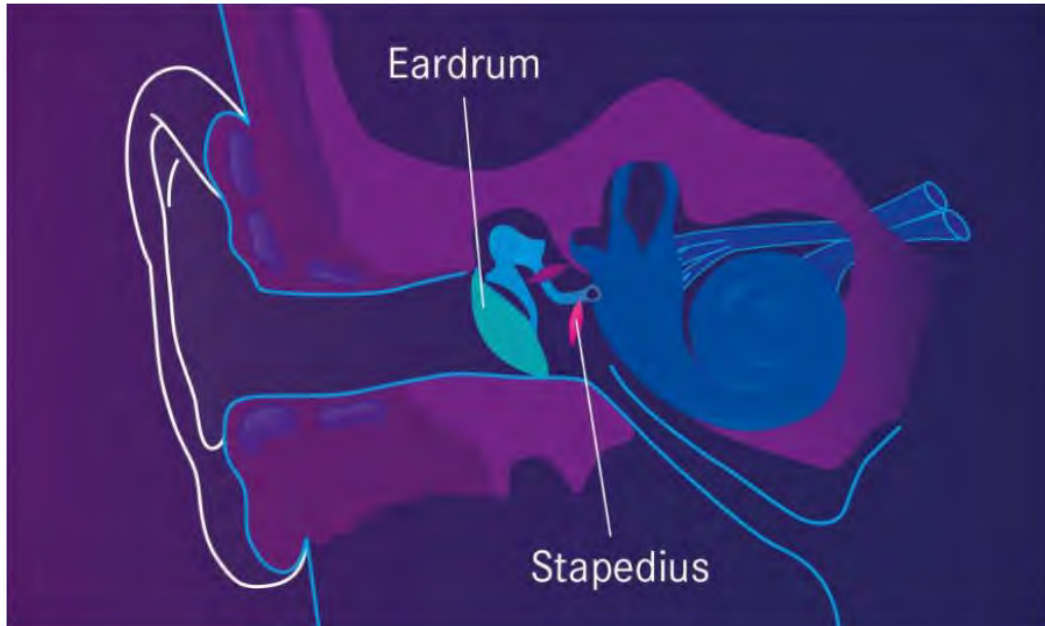

### **PRE-SAFE® Sound**

*Standard on all GLS models*

Part of PRE-SAFE, PRE-SAFE Sound is an acoustic occupant preconditioning system which can reduce the effects of the noise from an accident on the occupants hearing.

- When the PRE-SAFE system recognizes a certain dangerous situation, the onboard sound system plays a brief rushing sound, also known as 'Pink Noise', to precondition the hearing
- The natural reflex mechanism of the stapedius muscle enables the inner ear to rapidly prepare for the accident-induced high pressure sound
- Up to 40% reduction of noise exposure impact

## Automatic Car Wash Mode



### Automatic Car Wash Mode

Standard on all GLS models

One of the various new standard features is the automatic car wash mode - which comes in very handy, especially in a large and lavishly equipped vehicle like the GLS. When this function is selected, the suspension moves to the highest position, which reduces the track widths due to the axle geometry. This makes it easier to drive into a carwash as well as remove any dirt remaining in the wheel arches from the last off-road trip. And all equipment features that could cause a mishap when driving through the carwash are automatically secured:

- Folds in the exterior mirrors
- Displays the status of the side windows and the sliding sunroof
- Suppresses the rain sensor information so that the windscreen wipers remain switched off in the carwash
- Suppresses the alerts of PARKTRONIC
- Switches the climate control to air-recirculation mode and, after eight seconds, activates the 360° camera's front image to assist the driver when driving into the carwash
- These settings are automatically deactivated when the driver drives out of the carwash and accelerates to a speed above 12 mph.



## ***LED Intelligent Light System w/ ULTRA WIDE Highbeams and Adaptive Highbeam Assist***



### **LED Intelligent Light System w/ ULTRA WIDE Highbeams and Adaptive Highbeam Assist**

*Standard on all GLS models*

- Active curve illumination
- ULTRA WIDE Highbeams produce light at an increased width for maximum illumination of the road and surround area
- Adaptive Highbeam Assist is also part of the LED Intelligent Light System and allows drivers to drive with activated main beams without dazzling other road users





## MBUX Interior Assistant (Gesture Control)



### **MBUX Interior Assistant (77B)**

Option Price: \$300

*Not w/ Burmester® High-End 3D Surround Sound System (811)*

Enjoy contactless ease of operation: this innovative system detects and interprets your hand and arm movements. As such you can activate selected functions in a matter of seconds. As part of this the system is able to differentiate between driver and front passenger – so that you reach precisely the menus you wish to use.

- 3D camera in the overhead control panel, proximity sensors near the media display and touchpad
- The system detects and interprets hand movements and as part of this differentiates between the driver and front passenger
- Specifically highlights certain elements in the media display or enlarges them (media/radio, seat adjustment, navigation or Active Parking Assist)
- Activate reading lamp – by moving hand up and down beneath rear-view mirror
- Activate search light – stretch hand out towards the unoccupied front passenger seat
- Call up the personal favorites menu – defined gestures, form a "V" using index and middle fingers. This feature is customizable for both driver and passenger



## Head-Up Display



### **Head-Up Display (463)**

Option Price: \$1,100

*Optional on all GLS models*

The Head-Up Display at a glance:

- Key driver information at a glance (e.g. speed, speed limits, navigation prompts, warnings or settings for the driving assistance systems) without the driver having to take their eyes off the road
- Projection of a virtual image measuring approx. 9.45" x 3.15" into the driver's field of vision
- Presentation of information in high-resolution and in color, making it clearly legible even on sunny days and at night
- Height position of the image, brightness and displayed content can be changed individually via a menu in the instrument cluster and can be stored conveniently via the optional memory function for the driver's seat



## Availability of Heated & Ventilated Front Seats with MB-TEX



### **Heated & Ventilated Front Seats (401)**

Option Price: \$450

*Will be available with MB-TEX for the first time*

The climatized seats for driver and front passenger comprise seat heating and seat ventilation – for an ideal seat climate all year round. On hot days they provide you with a pleasantly refreshing temperature thanks to cooling ventilation. On cold days, meanwhile, the seat cushions and backrests emit a pleasant warmth.



## *ENERGIZING Package Plus*



### **ENERGIZING Package Plus (DB8PKG)**

Option Price: \$2,100

*Requires Warmth and Comfort Package (DB0PKG)*

The ENERGIZING package Plus is a new feature – it offers ultimate comfort for all the senses. To this end, a maximum of premium features are combined with innovative intelligence.

The exciting result: your Mercedes can vitalize and pamper you in specific ways. For prolonged alertness at the wheel and a very pleasant drive.

### **Programs**

- The "Refresh" program brings a breath of fresh air on board – an intense airflow and activation of the seat ventilation create a revitalizing atmosphere
- "Vitality" gives you new energy – e.g. by including lively music
- Cozy relaxation is the purpose of "Warmth", which activates the seat heating
- If you opt for "Joy", the focus is on an invigorating massage with wave-like lumbar movements
- Your seat also pleases you in the "Comfort" program – in this program you can enjoy both seat heating and a beneficial hot-stone massage with a pulsating lumbar effect
- "Training", on the other hand, is active rather than passive: you can put intermediate breaks to good use with exercise

 Additional functionality with Garmin® wearables (Smartwatch/Fitness Trackers)



## ***E-ACTIVE BODY CONTROL Package***



### **E-ACTIVE BODY CONTROL Package (DC7PKG)**

Option Price: \$6,500

*Optional on all GLS models*

*Requires tire diameter 790 (wheel size 20" or larger)*

E-ACTIVE BODY CONTROL is an all-new suspension system powered in part by the 48V battery and developed by Mercedes-Benz. By utilizing a Road Surface Scan and curve inclination function, an extraordinary level of comfort is made possible, and supports the claim of Mercedes-Benz to build the world's most intelligent SUV suspension.

- Only system on the market to control spring and damping forces individually at each wheel
- Hydropneumatics generate dynamic forces that overlay the air suspension forces and actively support and dampen the vehicle body during linear and lateral acceleration or when driving on uneven roads

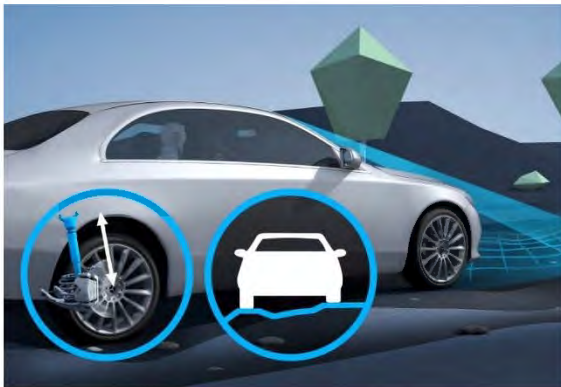





## *Driver Assistance Package Plus*

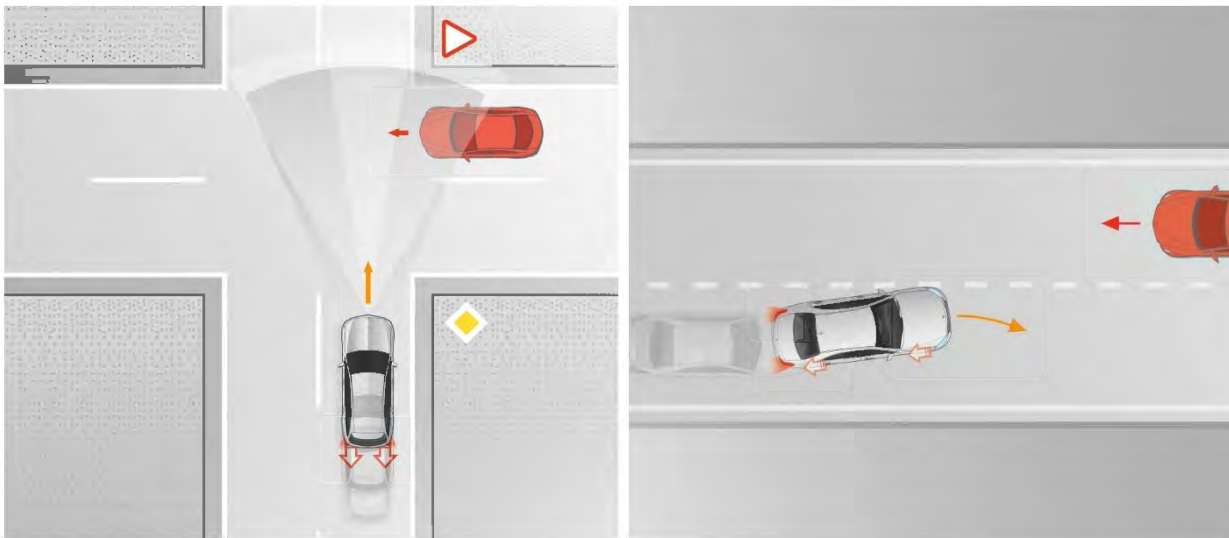
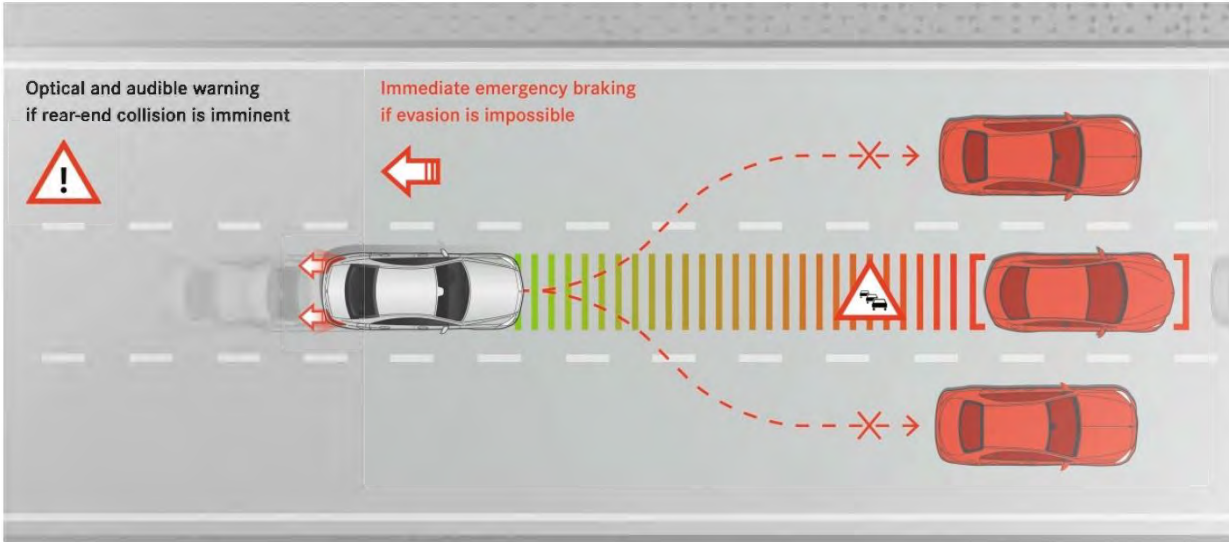

### Driver Assistance Package Plus (DA2PKG)

Option Price: \$2,250

**Latest-generation of our Advanced Driver Assistance System:** the enhanced intelligent hands-off detection includes sensing via the Touch Control Buttons and is sensitive to specific conditions and can be activated at a wide range of speeds.

- **Active Stop-and-Go Assist** see next slide
- **Active Distance Assist DISTRONIC®**
- **Active Steering Assist** can now actively intervene even if road lines are unclear or non-existent at certain speeds; it can now also function in curves with a tighter radius
- **Active Emergency Stop Assist** is able to brake the vehicle to a standstill in its lane if it detects that the driver is no longer actively driving the vehicle while it is on the move with Active Distance Assist DISTRONIC and Active Steering Assist engaged. It can now unlock the doors when the vehicle is stationary to allow first aid responders immediate access to the vehicle's interior
- **Active Lane Change Assist** is a radar-and-camera-based system that aids the driver when changing lanes. When a turn is indicated, this feature will aid with steering into the adjacent lane if it detects the lane is empty
- **Active Speed Limit Assist** can adapt vehicle speed to identified speed limits and can now adjust preemptively when speed limits are going to change.
- **Route-Based Speed Adaptation** is able to reduce the speed in anticipatory mode by referencing the vehicle's map data ahead of bends, junctions, roundabouts, toll booths and exit roads
- **Active Brake Assist with Cross-Traffic Function**
- **Evasive Steering Assist** this system assists by adding calculated steering torque to aid in steering wheel movement when a driver deliberately or instinctively performs an evasive maneuver around a pedestrian.
- **Active Blind Spot Assist** helps the driver to avoid an imminent side impact by sinGLS-sided braking.
- **Active Lane Keeping Assist**
- **PRE-SAFE® Impulse Side** see next slide



## *Driver Assistance Package Plus Highlights*



### **Mercedes-Benz Intelligent Drive – PRE-SAFE® Impulse Side**

*Included in Driver Assistance Package Plus (DA2PKG)*

- PRE-SAFE® Impulse Side initiates preventative protective measures against an impending side impact, supplementing the measures taken by PRE-SAFE® and PRE-SAFE® PLUS
- In the event of a side impact, PRE-SAFE® Impulse Side can have a positive effect by increasing the distance between the occupant and the door, and at the same time reducing the relative speeds between the side structure and the occupant's torso
- In the event of a recognized, unavoidable side collision, the system can give the driver or front passenger a slight push towards the center of the vehicle on the side facing the impact
- This lateral impulse is initiated by very rapid inflation of an air chamber in the seat bolster



### **Mercedes-Benz Active Stop-and-Go Assist**

*Included in Driver Assistance Package Plus (DA2PKG)*

- Enables the GLS to recognize traffic jams at an early stage, actively supporting the driver in stop-and-go traffic up to approx. 37 mph



## *Performance & Handling*

- 9G-TRONIC 9-Speed Automatic Transmission
- AIRMATIC Suspension w/ Adaptive Damping System ADS+
- 19" MB wheels
- All Season Tires
- New 3.0L inline-6 turbo engine with EQ-Boost (362 hp, 369 lb-ft, EQ-Boost outputs 21 hp and up to 184 lb-ft) (GLS 450 4MATIC)
- 4.0L V8 Bi-turbo engine with EQ-Boost (483 hp, 516 lb-ft, EQ-Boost outputs 21 hp and up to 184 lb-ft) (GLS 580 4MATIC)

## *Comfort & Convenience*

- KEYLESS-GO
- HANDS-FREE ACCESS
- Power Liftgate
- Remote Start
- Automatic Car Wash Mode
- LED Intelligent Light System
- Adaptive Highbeam Assist
- Power Tilt/Sliding Sunroof
- Multifunctional Steering Wheel with Touch Control Buttons
- Touchpad in Center Console
- MBUX User Interface incl. Voice Control with Natural Language Understanding
- 12.3" Digital Instrument Cluster and 12.3" Media Display with Touchscreen
- Apple CarPlay and Android Auto
- 9 USBs (3 in front, 2 in 2<sup>nd</sup> row, 4 in 3<sup>rd</sup> row)
- HERMES Communications Module LTE
- MB Navigation with Live Traffic and Map Updates
- Ambient Lighting with 64 Colors and Illuminated Door Sills
- Heated Front Seats
- Power Front Seats with 4-Way Lumbar Support and Memory Function
- 2-Zone Climate control
- Concierge Service
- Garage door opener
- Load Compartment Cover
- Spare Tire
- Double Sun Visors
- Privacy Glass
- Mirror Package (power folding mirrors, auto-dimming driver and rearview mirrors, mirror logo projector)
- Roof Rails
- 115V Household Type Power Outlet
- Active Parking Assist with Surround View System
- Wireless Charging
- Burmester® Surround Sound System
- SiriusXM® Radio

## *Safety & Security*

- Active Brake Assist
- Anti-Theft Alarm System
- ATTENTION ASSIST
- Blind Spot Assist
- Car Exit Warning
- Crosswind Assist
- Emergency Call Service
- PRE-SAFE®

# Exterior Paint Colors



## Non-metallic Paints



040U  
Black  
Option price: \$0



149U  
Polar White  
Option price: \$0

## Metallic Paints



197U  
Obsidian Black  
Option price: \$720

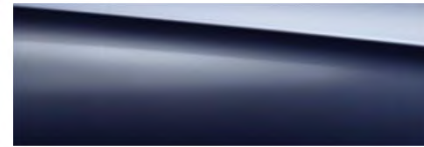

890U  
Lunar Blue  
Option price: \$720



775U  
Iridium Silver  
Option price: \$720



989U  
Emerald Green  
Option price: \$720



859U  
Mojave Silver  
Option price: \$720



896U  
Brilliant Blue  
Option price: \$720



992U  
Selenite Grey  
Option price: \$720

## *designo*<sup>®</sup> Paints



799U  
Diamond White bright  
Option price: \$1,515



996U  
Cardinal Red metallic  
Option price: \$1,080



**65R**

19" Twin 5-Spoke Wheels

R02, 690

Standard

**94R**

20" 8-Spoke Wheels

R02, 690

Option price: \$750

**R33**

20" Twin 5-Spoke Wheels

R02, 690

Option price: \$950

**95R**

21" Triple 5-Spoke Wheels

R02, 690

Option price: \$1,750

**R76**

21" 5-Spoke Wheels

R02, 690

Option price: \$1,750

**GLS 580 only**

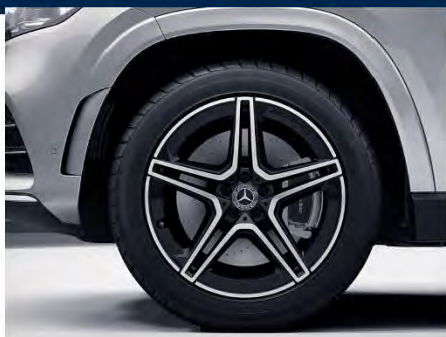

**RWF**

21" AMG Twin 5-Spoke Wheels

R02, 690

Standard

**RWH**

21" AMG Twin 5-Spoke Wheels

w/ Black Accents

R02, 690

Option price: \$0

*Requires Night Package (DC1PKG)*

**RPA**

22" AMG Multi-Spoke Wheels

R01, 690

Option price: \$1,250

**RPB**

22" AMG Multi-Spoke Wheels

w/ Black Accents

R01, 690

Option price: \$1,250

*Requires Night Package (DC1PKG)*

**RPQ**

23" AMG Twin 5-Spoke Wheels

w/ Black Accents

R01, 690

Option price: \$2,950





<i>Code</i>	<i>Wheel Size</i>	<i>Description</i>	<i>Wheel Dimensions</i>		<i>Mobility</i>	<i>Availability</i>	<i>MSRP</i>
65R	19"	Twin 5-Spoke Wheels	275/55 R 19 on 8.5 J x 19 ET 62 275/55 R 19 on 8.5 J x 19 ET 62	(Front) (Rear)	R02, 690	GLS 450 only	\$ 0
94R	20"	8-Spoke Wheels	275/50 R 20 on 8.5 J x 20 ET 62.5 275/50 R 20 on 8.5 J x 20 ET 62.5	(Front) (Rear)	R02, 690	GLS 450 only	\$ 750
R33	20"	Twin 5-Spoke Wheels	275/50 R 20 on 8.5 J x 20 ET 62.5 275/50 R 20 on 8.5 J x 20 ET 62.5	(Front) (Rear)	R02, 690	GLS 450 only	\$ 750
95R	21"	Triple 5-Spoke Wheels	275/45 R 21 on 10 J x 21 ET 62.5 315/40 R 21 on 11 J x 21 ET 55	(Front) (Rear)	R02, 690	GLS 450 only	\$ 1,750
R76	21"	5-Spoke Wheels	275/45 R 21 on 10 J x 21 ET 62.5 315/40 R 21 on 11 J x 21 ET 55	(Front) (Rear)	R02, 690	GLS 450 only	\$ 1,750
RWF	21"	AMG Twin 5-Spoke Wheels	275/45 R 21 on 10 J x 21 ET 44 315/40 R 21 on 11 J x 21 ET 42	(Front) (Rear)	R02, 690	GLS 580 only	\$ 0
RWH	21"	AMG Twin 5-Spoke Wheels w/ Black Accents	275/45 R 21 on 10 J x 21 ET 44 315/40 R 21 on 11 J x 21 ET 42	(Front) (Rear)	R02, 690	GLS 580 only	\$ 0 <i>Requires Night Package (DC1PKG)</i>
RPA	22"	AMG Multi-Spoke Wheels	285/45 R 22 on 9.5 J x 22 ET 45 325/40 R 22 on 11.5 J x 22 ET 47	(Front) (Rear)	R01, 690	GLS 580 only	\$ 1,250
RPB	22"	AMG Multi-Spoke Wheels w/ Black Accents	285/45 R 22 on 9.5 J x 22 ET 45 325/40 R 22 on 11.5 J x 22 ET 47	(Front) (Rear)	R01, 690	GLS 580 only	\$ 1,250 <i>Requires Night Package (DC1PKG)</i>
RPQ	23"	AMG Twin 5-Spoke Wheels w/ Black Accents	285/40 R 23 on 9.5 J x 23 ET 45 325/35 R 23 on 11.5 J x 23 ET 47	(Front) (Rear)	R01, 690	GLS 580 only	\$ 2,750



111  
Black  
Option price: \$0



114  
Espresso Brown  
Option price: \$0



115  
Macchiato Beige/Magma Grey  
Option price: \$0

---

*MB-Tex not with Multicontour Seats (399)*



201\*  
Black  
Option price: \$1,620



204\*  
Espresso Brown/Magma Grey  
Option price: \$1,620



205  
Macchiato Beige/Magma Grey  
Option price: \$1,620



284\*  
Black/Tartufo  
Option price: \$1,620



# Interior Upholstery – Exclusive Nappa Leather



958

Black/Magma Grey Exclusive Nappa leather

Option price: \$2,990 (GLS 450)/\$1,370 (GLS 580)





<i>Code</i>	<i>Upholstery</i>	<i>Seats</i>	<i>Floor Mats</i>	<i>Upper Dash/Lower Dash</i>	<i>Seat Belts</i>	<i>Steering Wheel</i>	<i>Headliner</i>
111	Black MB-Tex	Black	Black	Black/Black	Black	Black	Crystal Grey or Black
114	Espresso Brown MB-Tex	Espresso Brown	Magma Grey	Magma Grey/Espresso Brown	Magma Grey	Magma Grey	Crystal Grey
115	Macchiato Beige/Magma Grey MB-Tex	Macchiato Beige	Magma Grey	Magma Grey/Macchiato Beige	Macchiato Beige	Magma Grey	Macchiato Beige
201	Black leather	Black	Black	Black/Black	Black	Black	Crystal Grey or Black
204	Espresso Brown/Magma Grey leather	Espresso Brown	Magma Grey	Magma Grey/Espresso Brown	Magma Grey	Magma Grey	Crystal Grey or Black
205	Macchiato Beige/Magma Grey leather	Macchiato Beige	Magma Grey	Magma Grey/Macchiato Beige	Macchiato Beige	Magma Grey	Macchiato Beige
284	Black/Tartufo leather	Tartufo	Black	Black/Black	Black	Black	Crystal Grey or Black
958	Black/Magma Grey Exclusive Nappa leather	Magma Grey	Black	Magma Grey/Magma Grey (with U38) or Black/Black (with U09)	Magma Grey	Black	Crystal Grey or Black

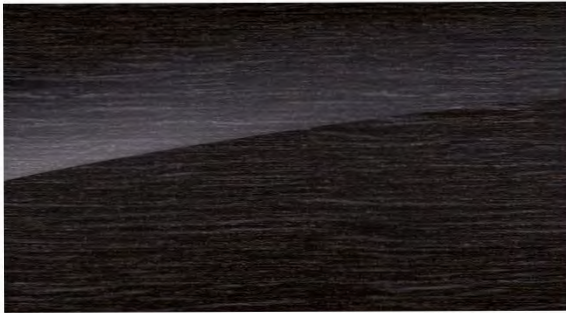

H18  
Grey Linden Wood  
Standard



H22  
Natural Grain Brown Walnut Wood  
Option price: \$160

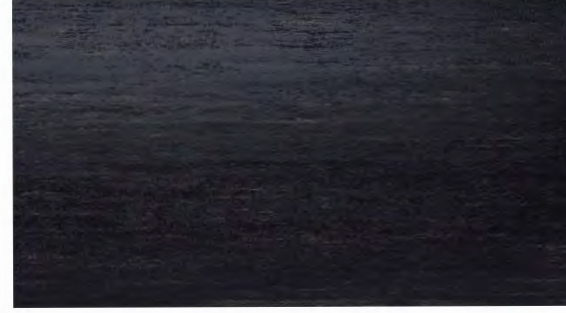

H31  
Natural Grain Grey Oak Wood  
Option price: \$160



H46  
Aluminum (longitudinal grain)  
Option price: \$0

Available as of 01/2020 Production

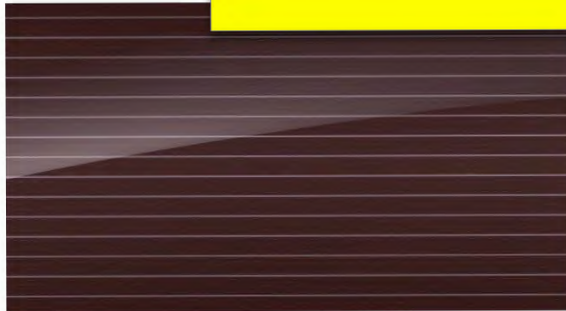

H34  
*designo*® Brown Linden 'Flowing Lines'  
Wood  
Option price: \$850

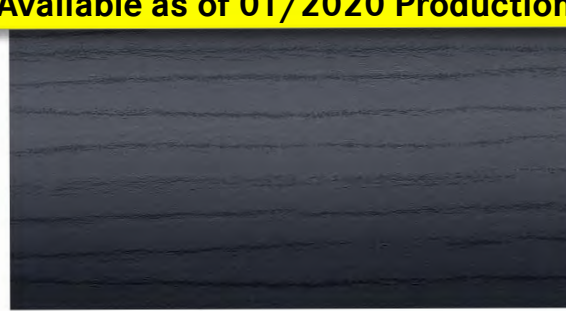

H35  
*designo*® Black Flamed Natural Grain Ash  
Wood  
Option price: \$850

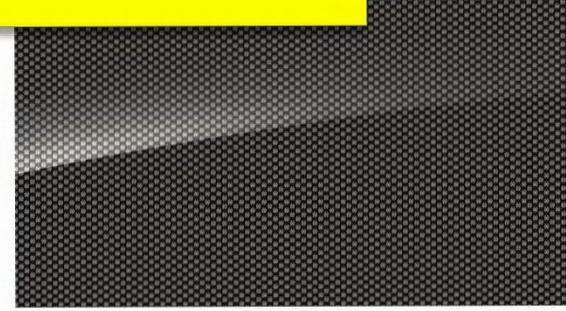

H64  
Metal Weave  
Option price: \$600



<i>Code</i>	<i>Packages</i>	<i>Availability</i>	<i>MSRP</i>
DA1PKG	<p><b>Convenience Package</b></p> <ul style="list-style-type: none"> <li>▪ 581 – 4-Zone Climate Control</li> <li>▪ 401 – Heated and Ventilated Front Seats</li> <li>▪ 297 – Electric Rear Side-Window Sunshades</li> </ul>	Available on GLS 450	\$ 1,750
DA2PKG	<p><b>Driver Assistance Package Plus</b></p> <p><i>Requires Multicontour Front Seats (399)</i></p> <p>P20 – Driver Assistance Package Plus</p> <ul style="list-style-type: none"> <li>▪ Active Stop-and-Go Assist</li> <li>▪ 233 – Active Distance Assist DISTRONIC</li> <li>▪ 266 – Active Steering Assist</li> <li>▪ Active Emergency Stop Assist</li> <li>▪ Active Lane Change Assist</li> <li>▪ 546 – Active Speed Limit Assist</li> <li>▪ Route-Based Speed Adaptation</li> <li>▪ Active Brake Assist with cross-traffic function</li> <li>▪ Evasive Steering Assist</li> <li>▪ Active Blind Spot Assist</li> <li>▪ Active Lane Keeping Assist</li> <li>▪ 253 – PRE-SAFE® PLUS with rear-end collision protection</li> <li>▪ 292 – PRE-SAFE® Impulse Side</li> <li>▪ 513 – Traffic Sign Assist</li> </ul>	All Models	\$ 2,250



<i>Code</i>	<i>Packages</i>	<i>Availability</i>	<i>MSRP</i>
DB0PKG	<b>Warmth and Comfort Package</b> <ul style="list-style-type: none"> <li>▪ P69 – Warmth and Comfort Package                             <ul style="list-style-type: none"> <li>▪ 906 – Heated Armrest</li> <li>▪ 907 – Heated Armrest in the Rear</li> <li>▪ 902 – Rapid Heating Seats</li> </ul> </li> </ul>	All Models	\$ 1,050
DB5PKG	<b>Executive Rear Seat Package</b> <i>Only in combination w/ 7 Seater Configuration (226)</i> <ul style="list-style-type: none"> <li>▪ P11 – Executive Rear Seat Package                             <ul style="list-style-type: none"> <li>▪ 437 – Comfort Headrests in the Rear</li> <li>▪ 898 – Wireless Charging in the Rear</li> <li>▪ 447 – MBUX Rear Tablet</li> </ul> </li> <li>▪ 293 – Sidebags in the Rear</li> </ul>	All Models	\$ 2200
DB6PKG	<b>Executive Rear Seat Package Plus</b> <i>Not w/ Executive Rear Seat Package (DB5PKG)</i> <i>Only in combination w/ 7 Seater Configuration (226)</i> <i>Requires Heated and Ventilated Seats (401)</i> <ul style="list-style-type: none"> <li>▪ P11 – Executive Rear Seat Package</li> <li>▪ 402 – Heated and Ventilated Seats in the Rear</li> <li>▪ 406 – Multicontour Seats in the Rear w/ massage function</li> </ul>	All Models	\$ 4400
DB8PKG	<b>ENERGIZING Package Plus</b> <i>Requires Warmth and Comfort Package (DB0PKG)</i> <ul style="list-style-type: none"> <li>▪ P21 – AIR-BALANCE Package with fragrance</li> <li>▪ 401 – Heated and ventilated Front Seats</li> <li>▪ 399 – Active Multicontour Front Seats w/ massage function</li> </ul>	All Models	\$ 2,100



<i>Code</i>	<i>Packages</i>	<i>Availability</i>	<i>MSRP</i>
DC1PKG	<b>Night Package</b> <ul style="list-style-type: none"> <li>▪ P55 – Night Package                             <ul style="list-style-type: none"> <li>▪ High-gloss black elements: louvre in radiator grille, front apron trim strip, simulated underguard, rear apron trim strip, side mirrors, window line trim strip, beltline trim strip</li> <li>▪ Matte black elements: roof rails</li> <li>▪ Wheel choice of:                                     <ul style="list-style-type: none"> <li>• RWH – 21" AMG 5-Spoke Wheels w/ Black Accents</li> <li>• RPB – 22" AMG Multi-Spoke Wheels w/ Black Accents (+ \$1,250)</li> </ul> </li> </ul> </li> </ul>	Available on GLS 580	\$ 400
DC5PKG	<b>Acoustic Comfort Package</b> <ul style="list-style-type: none"> <li>▪ PAF – Acoustic Comfort Package                             <ul style="list-style-type: none"> <li>▪ Increased cabin insulation, windshield and side windows with acoustic and heat absorbing membrane</li> <li>▪ Infrared-reflecting glass</li> </ul> </li> </ul>	All Models	\$ 1,100
DC7PKG	<b>E-ACTIVE BODY CONTROL Package</b> <ul style="list-style-type: none"> <li>▪ 490 – E-ACTIVE BODY CONTROL</li> <li>▪ 481 – Underguard</li> </ul>	All Models	\$ 6,500

# Stand-Alone Options



<i>Code</i>	<i>Options</i>	<i>Availability</i>	<i>MSRP</i>
243	<b>Active Lane Keeping Assist</b> <i>Not w/ Driver Assistance Package Plus (DA2PKG)</i>	All Models	\$ 550
297	<b>Electric Rear Side-Window Sunshades</b> <i>Available in Convenience Package (DA1PKG) for GLS 450</i>	Available on GLS 580	\$ 380
307	<b>Heated/Cooled Cup Holder in Rear</b> <i>Requires Executive Rear Seat Package (DA5PKG) or Executive Rear Seat Package Plus (DA6PKG)</i>	All Models	\$ 180
311	<b>Heated/Cooled Cup Holders</b>	All Models	\$ 180
399	<b>Active Multicontour Front Seats with Massage Function</b> <i>Requires Heated and Ventilated Front Seats (401) Requires Rapid Heating Seats (902) or Warmth and Comfort Package (DB0PKG) Requires Leather or Nappa Leather upholstery</i>	Available on GLS 450 Standard on GLS 580	\$ 1,100
401	<b>Heated and Ventilated Front Seats</b>	Available on GLS 450 Standard on GLS 580	\$ 450
413	<b>Panorama Sliding Sunroof</b>	All Models	\$ 1,000
430	<b>Off-Road Package</b> <i>Requires Underguard (481) or E-ACTIVE BODY CONTROL Package (DC7PKG)</i>	Available on GLS 580	\$ 1,900
443	<b>Steering Wheel Heating</b> <i>Only w/ round steering wheels L3B or L3D</i>	All Models	\$ 250
463	<b>Head-Up Display</b>	All Models	\$ 1,100
481	<b>Underguard</b> <i>Requires Off-Road Package (430) or E-ACTIVE BODY CONTROL Package (DC7PKG)</i>	All Models	\$ 0
513	<b>Traffic Sign Assist</b>	All Models	\$ 295
550	<b>Trailer Hitch</b> <i>Includes Increased Towing Capacity (557); Please note: no accessory retrofit available</i>	All Models	\$ 575



<i>Code</i>	<i>Options</i>	<i>Availability</i>	<i>MSRP</i>
581	<b>4-Zone Climate Control</b>	Available on GLS 450	\$ 860
582	<b>5-Zone Climate Control</b> <i>Requires 4-Zone Climate Control (581)</i>	Available on GLS 450 Standard on GLS 580	\$ 400
735	<b>Exclusive Trim Package</b> <i>Not w/ Aluminum (H46) or Metal Weave (H64) Trim</i>	All Models	\$ 450
811	<b>Burmester® High-End 3D Surround Sound System</b> <i>Not with MBUX Interior Assistant (77B)</i>	All Models	\$ 4,550
846	<b>Illuminated Running Boards</b> <i>Please note: no accessory retrofit available</i>	Available on GLS 450 Standard on GLS 580	\$ 650
872	<b>Heated Rear Seats</b>	All Models	\$ 580
874	<b>MAGIC VISION CONTROL</b> <i>incl. Heated Windscreen Washer System</i>	All Models	\$ 350
883	<b>Soft Close Doors</b>	Available on GLS 450 Standard on GLS 580	\$ 550
886	<b>Heated 3<sup>rd</sup> Row Seats</b> <i>Requires Heated Rear Seats (872) or Heated and Ventilated Front Seats (402)</i> <i>Requires 5-Zone Climate Control (582) - restriction is valid until Dec 2019 -</i>	All Models	\$ 360
61U	<b>Headliner DINAMICA black</b> <i>Not available with upholstery 115A or 205A</i>	All Models	\$ 1,600
77B	<b>MBUX Interior Assistant (Gesture Control)</b> <i>Not w/ Burmester® High-End 3D Surround Sound System (811)</i>	All Models	\$ 300
L3D	<b>Wood/Leather Multifunction Steering Wheel</b> <i>Requires Natural Grain Brown Walnut Wood Trim (H22) or Natural Grain Grey Oak Wood Trim (H31) or designo® Brown Linden 'Flowing Lines' Wood Trim (H34)</i>	All Models	\$ 600
P21	<b>AIR-BALANCE Package with Fragrance</b>	All Models	\$ 350





<i>Code</i>	<i>Options</i>	<i>Availability</i>	<i>MSRP</i>
U09	<b>Lower Dashboard &amp; Door Beltlines in MB-Tex</b>	All Models	\$ 350
U19	<b>MBUX Augmented Reality for Navigation</b>	All Models	\$ 300
U38	<b>Dashboard &amp; Door Beltlines in Nappa Leather</b> <i>Requires Black / Magma Grey Exclusive Nappa Leather (958A)</i>	All Models	\$ 1,050

<i>Code</i>	<i>Special Order Options (additional charge of \$250)</i>	<i>Availability</i>	<i>MSRP</i>
293	<b>Sidebags in the Rear</b>	All Models	\$ 420
U28	<b>Sports brake system with perforated front brake discs, larger brake size and brake calliper trim with "Mercedes-Benz" lettering</b>	Available on GLS 450 <i>Standard on GLS 580</i>	\$ TBD
R01	<b>High Performance Tires</b> <i>Only w/ 95R or R76, Requires E-ACTIVE BODY CONTROL (DC7PKG)</i>	Available on GLS 450	\$ TBD

<i>Code</i>	<i>VPC Installed Accessories</i>	<i>Availability</i>	<i>MSRP</i>
D03	<b>Illuminated Star</b> <i>Not available with Driver Assistance Package Plus (DA2PKG)</i>	All Models	\$ TBD
D08	<b>Chrome Door Handle Inserts</b>	All Models	\$ TBD
D11	<b>Roof Spoiler</b>	All Models	\$ TBD
D24	<b>Black Side Cladding</b>	All Models	\$ TBD
D25	<b>USB-C Adapter Cable</b>	All Models	\$ TBD
D26	<b>Load Sill Protector</b>	All Models	\$ TBD
D27	<b>Wheel Locking Bolts, Silver</b>	All Models	\$ TBD



## Steering Wheels



### **Nappa Leather Multifunction Steering Wheel (L3B)**

*Standard on GLS 450*

- Newly redesigned 3-spoke multifunction steering wheel in nappa leather
- Touch control buttons for direct control of the instrument cluster and to control the functions of the multimedia system
- Bezel and buttons in silver chrome
- Panels in high-gloss black
- Shift paddles in black



### **Wood/Leather Multifunction Steering Wheel (L3D)**

Option Price: \$600

*Requires trim H22 or H31 or H34*

- Newly redesigned 3-spoke multifunction steering wheel in wood/leather
- Touch control buttons for direct control of the instrument cluster and to control the functions of the multimedia system
- Bezel and buttons in silver chrome
- Panels in high-gloss black
- Shift paddles in black



### **Nappa Leather Multifunction Sport Steering Wheel (L5C)**

*Standard on GLS 580*

*Not with Steering Wheel Heating (443)*

- Newly redesigned 3-spoke multifunction sport steering wheel in nappa leather with flattened bottom section and perforated grip area
- Touch control buttons for direct control of the instrument cluster and to control the functions of the multimedia system
- Bezel, panels and buttons in silver chrome
- Shift paddles in silver chrome



### **Steering Wheel Heating (443)**

Option Price: \$250

- On cold days, the heated 3-spoke steering wheel rim very quickly warms the grip area of the steering wheel to ensure pleasantly warm hands.
- The function is switched on and off by turning the control lever for adjusting the multifunction steering wheel.



## ***Burmester® Surround Sound Systems***



### **Burmester® Surround Sound System (810)**

*Standard*

- 13 high-performance speakers precisely configured for the vehicle interior to ensure well-balanced and very dynamic music reproduction
- 9-channel DSP amplifier with a total output of 590 watts (7 x 50 W and 2 x 120 W) for maximum sound quality with very high volume reserves
- Frontbass® technology with woofers integrated into the body-in-white
- Sound optimization for the front and rear seats
- Vehicle noise compensation (VNC)
- Sound preset: surround function to generate virtual all-round sound
- Support for popular multi-channel formats for true surround sound



### **Burmester® High-End 3D Surround Sound System (811)**

Option Price \$4,550

*Not with MBUX Interior Assistant (77B), AMG Line Exterior (DG1)*

- 26 high-end speakers including subwoofer and speaker units in the roof liner
- 27-channel amplifier with digital and active analogue filters and an output of 1,210 watts plus an additional subwoofer booster amplifier delivering 400 watts (total system output 1,610 watts)
- VIP seat function to optimize the sound for individual seats
- Mid-range, low- to mid-range and Frontbass speakers with membranes made of glass-fiber fabric
- Noise compensation (VNC) for dynamic equalizing
- Supports multichannel audio formats



## Exclusive Trim Package



### **Exclusive Trim Package (735)**

Option Price: \$450

The Trim package lends your interior an individual look. Additional trim elements on the back of the front seat backrests blend seamlessly into the interior, creating some exciting contrasts. The rear seat passengers in particular can enjoy an enhanced sense of high-class appeal.

- **Additional trim elements on the back of the front seat backrests – optionally in:**
  - Grey Linden Wood (H18)
  - Natural Grain Brown Walnut Wood (H22)
  - Natural Grain Grey Oak Wood (H31)
  - *designo* Brown Linden 'Flowing Lines' Wood (H34)
  - *designo* Black Flamed Natural Grain Ash Wood (H35)
  
- **Map pockets in MB-Tex**

## Off-Road Package



### Off-Road Package (430)

Option Price: \$1,900

Requires Underguard (481)

Innovative combination for superior ride comfort both on and off the road: in this package, a fully-variable all-wheel drive system works together with a low-range transmission. Ideal for dynamic progress on metaled roads and finely metered torque distribution off the beaten track. So that you experience the perfect balance between agility and stability.

- **Fully-variable all-wheel drive and low-range transmission:**
  - Torque-on-demand (double-speed) for traction and dynamic control
  - Inter-axle locking is via a torque-on-demand clutch, giving variable distribution of the drive torque from 0–100% between the axles
  - Low-range off-road gearing
  - Downhill Speed Regulation for steep downhill gradients
  - Off-road ABS with specific optimization for rough surfaces
  - Special off-road algorithm for ABS, 4ETS, ESP®, front and rear axles with adapted 4ETS
- **Special control panel in the center console**
- **DYNAMIC SELECT driving modes:**
  - Offroad (with extended functions): optimum all-wheel drive performance on light terrain, e.g. on sand
  - Offroad+ (exclusively available with this package): outstanding traction on difficult/steep terrain, e.g. on rocky/stony surfaces
  - Comfort: compensating suspension setup for metaled roads
  - Sport: taut suspension setup with rear torque bias
- **Underguard for the entire underbody**



## Night Package



**GLS 580 4MATIC**



**GLS 580 4MATIC w/ Night Package (DC1PKG)**



## *Roof Spoiler*



### **Roof Spoiler (D11)**

Option price: TBD

The roof spoiler (painted in the vehicle color) gives the rear of the vehicle a more dynamic and sporty look. Does not affect field of vision in rear-view mirror.



## Black Side Claddings



### **Black Side Claddings (D24)**

Option price: TBD

- New GLS side cladding highlights new GLS side lines
- Side cladding protects vehicle from unwanted contacts
- Matt black surface
- New design feature adding an individual look to light colored customer vehicles
- Covers front and rear doors

European picture shown – wheels n/a in US





	<i>GLS 450 4MATIC</i>	<i>GLS 580 4MATIC</i>
Engine Configuration	3.0L Inline-6 Turbo Engine with EQ-Boost	4.0L V8 Bi-Turbo Engine with EQ-Boost
Power (hp)	362	483
Electric motor (hp), System output (hp)	21	21
Torque (lb-ft)	369	516
Electric Motor (lb-ft), System Torque (lb-ft)	184	184
Displacement (cc)	2,999	3,982
Acceleration 0-60 mph (sec)	5.9	5.2
Fuel Economy (Cty/Hwy/Comb)	Tbd	Tbd
Top Speed (mph)	130	130
Fuel Requirement (Octane)	91	91
Compression	10.5 : 1	10.5:1
Transmission	9G-TRONIC 9-Speed Automatic Transmission	9G-TRONIC 9-Speed Automatic Transmission
Transmission Speeds	9	9
Drive Configuration	All-wheel drive	All-wheel drive
Fuel Tank Size (gallons)	23.8	23.8
Trunk Size (cubic feet)	48.7	48.7
Curb Weight (lbs)	Tbd	Tbd
Maximum Load (lbs)	Tbd	Tbd
Vehicle Length (in.)	205.0	205.2
Vehicle Width w/ exterior mirrors (in.)	84.9	84.9
Vehicle Height (in.)	71.8	71.8
Wheelbase (in.)	123.4	123.4
Track Width Front/Rear (in.)	65.7/66.6	67.1/68.2
Towing Capacity (lbs)	7,700	7,700

# Specifications\* – GLS 450 4MATIC

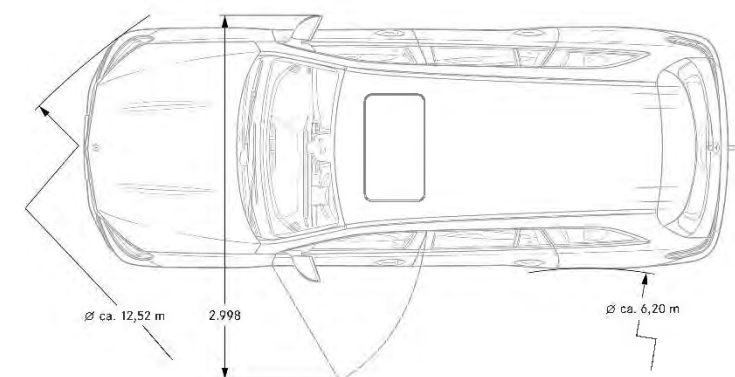
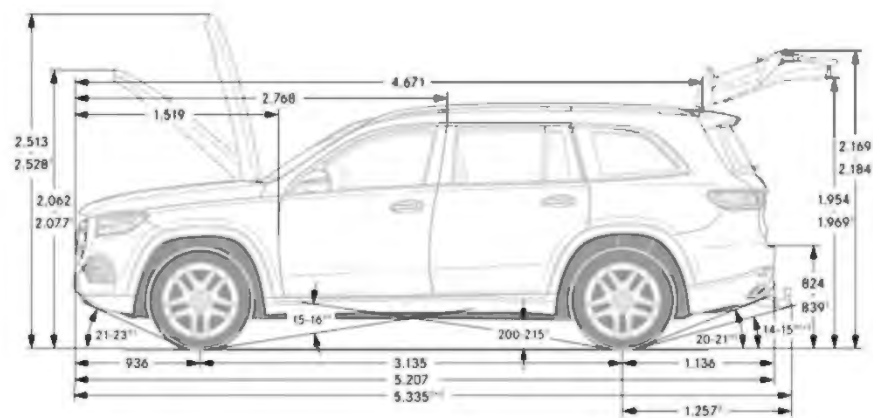
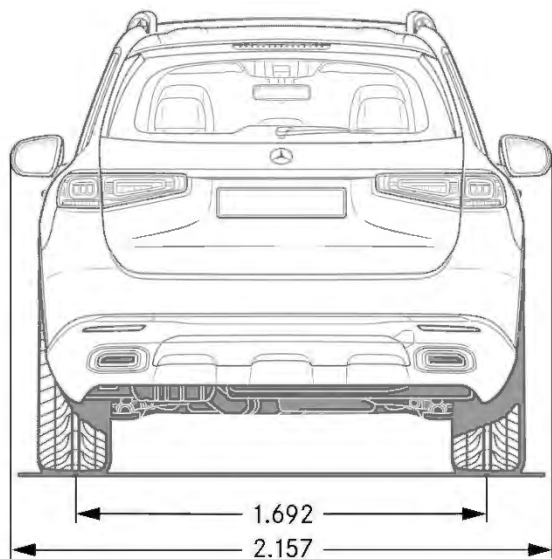
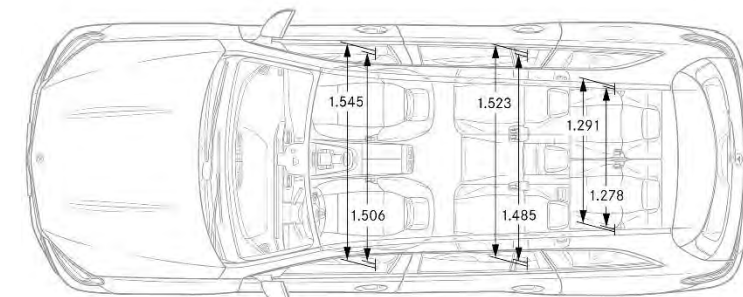
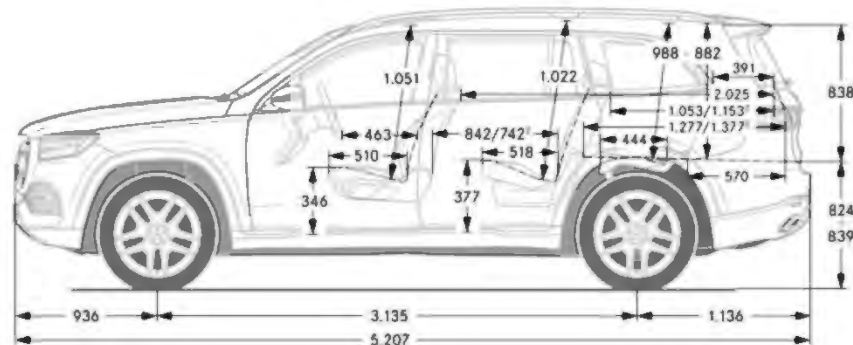
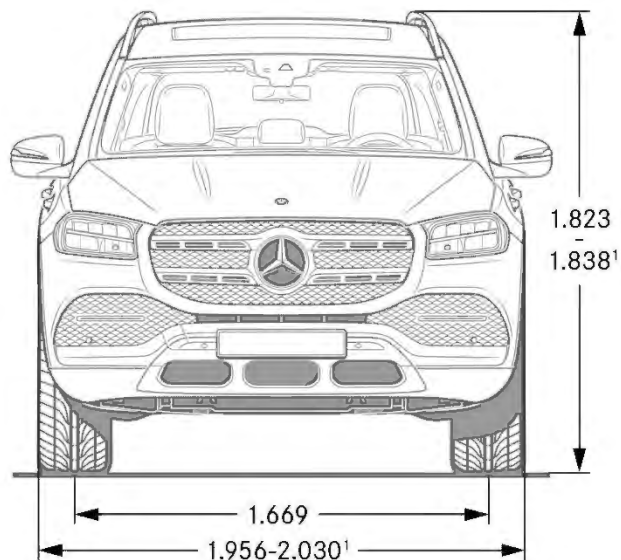

# Specifications\* – GLS 580 4MATIC

