

AR27.00-P-0101A	Inspect ATF level in automatic transmission, add ATF if necessary	24.1.95
-----------------	---	---------

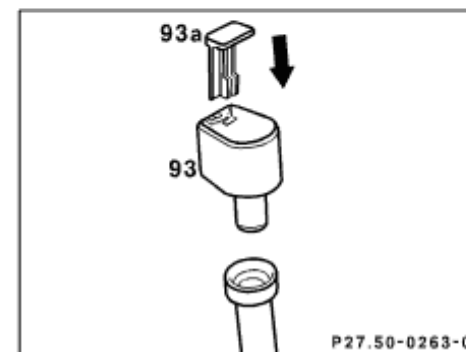

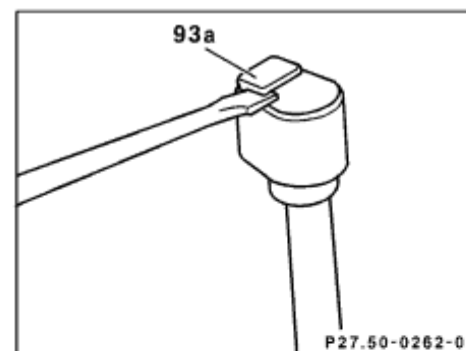

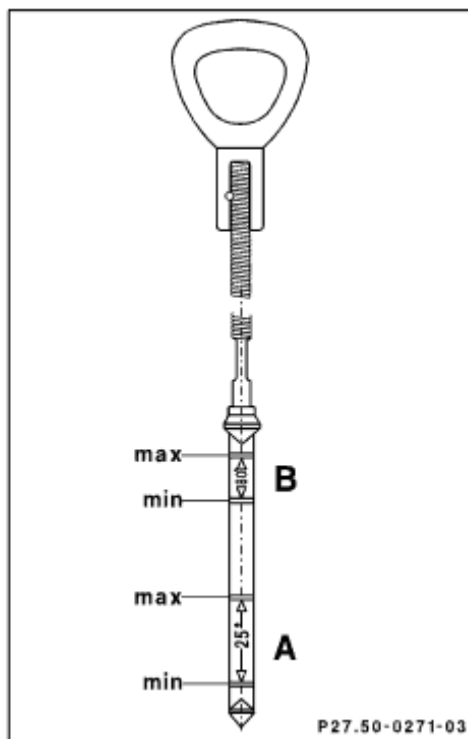





TRANSMISSION 722.6





93 Cap
 93a Locking pin
 A 25 °C (77 °F)
 B 80 °C (180 °F)



P27.50-0274-06

	Adding transmission oil		
<p>Danger!</p>	<p>Risk of accident caused by vehicle starting off by itself when engine is running. Risk of injury caused by contusions and burns when working in engine during starting procedure</p>	<p>Secure vehicle to prevent it from moving. Wear closed and snug-fitting work clothes. Do not grasp hot or rotating parts.</p>	<p>AS00.00-Z-0005-01A</p>

1	Remove locking pin (93a)	 Remove locking pin by breaking off the plate of the locking pin with a suitable tool and pressing out the pin remaining in the cap (93) downwards.	
2	Take off cap (93)		
3	Fill with transmission oil	 When refilling and after changing the oil, pour in approx. 5 l of transmission oil before starting the engine. Insufficient and excessive quantities of oil result in malfunctions and transmission damage.	
		 The vehicle must be horizontal.	
			BF27.00-P-1001-01C
			126 589 12 63 00
			140 589 49 63 00
4	Start engine and allow to idle in selector lever position "P"	 When refilling, refill with the rest of the specified oil quantity.	
5	Shift through the driving stages several times with the vehicle stationary and the engine idling	 Operate service brakes at the same time.	
	Check		
6	Check oil level and correct if necessary	 Operate service brakes at the same time. With a cold transmission, the oil level indicator must be between the "min" and "max" markings at a transmission oil temperature of 25 °C (77 °F) (A). The exact oil level must be between the "min" and "max" markings at a transmission oil temperature of 80 °C (180 °F) (B).	
		 If the STAR DIAGNOSIS is used, the current transmission oil	

		temperature must be read out in one of the selector lever positions R, D, 4, 3, 2 or 1.	
			WE58.40-Z-1013-06A
7	Insert dipstick fully and remove again, read off oil level, repeat if necessary	 If too much transmission oil is added, it is absolutely essential to drain off or extract the surplus. Insufficient and excessive quantities of oil result in malfunctions and transmission damage.	
		 Warm up the transmission, wait at least 2 minutes and check the oil level with the engine running.	
			140 589 15 21 00
			210 589 00 71 00
8	Check oil level again and correct if necessary		
9	Fit cap (93) on oil filler pipe and press in new locking pin (93a) until it locks in position.		
10	Check transmission for leaks	 If there is oil leakage, determine and eliminate the cause, otherwise malfunctions, transmission damage and also serious environmental pollution may result.	

 **Automatic transmission**

Number	Designation			Transmission 722.662
BF27.00-P-1001-01C	Filling capacity	Initial charge	Liters	7.5 (+0.5)
		Oil change	Liters	-
		Specifications for Operating Fluids	Sheet	BB00.40-P-0236-10A

			Sheet	BB00.40-P-0236-12A
--	--	--	-------	------------------------------------

 **Automatic transmission**

Number	Designation			Transmission 722.663/666
BF27.00-P-1001-01C	Filling capacity	Initial charge	Liters	8.6+0.5
		Oil change	Liters	-
		Specifications for Operating Fluids	Sheet	BB00.40-P-0236-10A
			Sheet	BB00.40-P-0236-12A



126 589 12 63 00

Funnel



140 589 15 21 00

Dipstick



140 589 49 63 00

Filling pipe

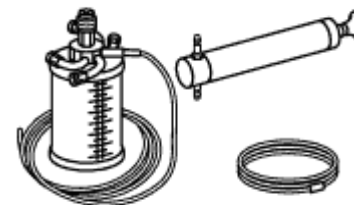

210 589 00 71 00

Hand pump

Workshop equipment/MB testers (see Workshop Equipment Manual)

WE58.40-Z-1013-06A	STAR DIAGNOSIS Compact diagnosis system for passenger cars, order number 6511 1801 00
--------------------	---