

AR46.10-P-0800GH

Remove/install lock cylinder

6.3.97

MODEL 163

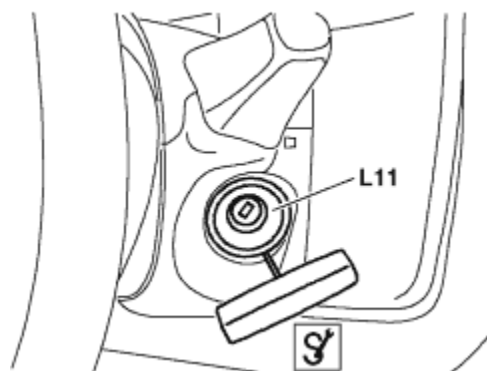

P46.10-0437-01

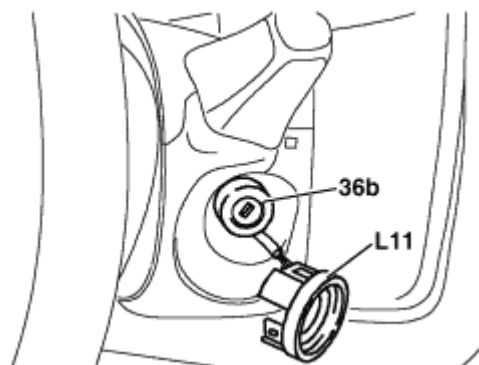

P46.10-0438-01

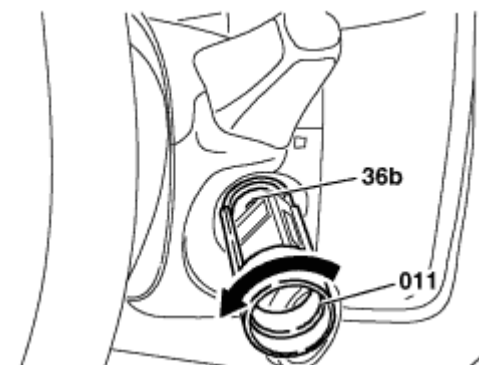

P46.10-0439-01

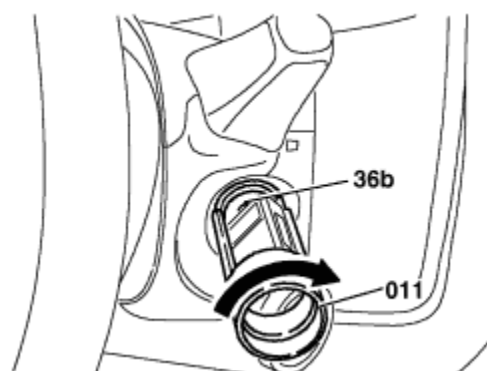

P46.10-0442-01

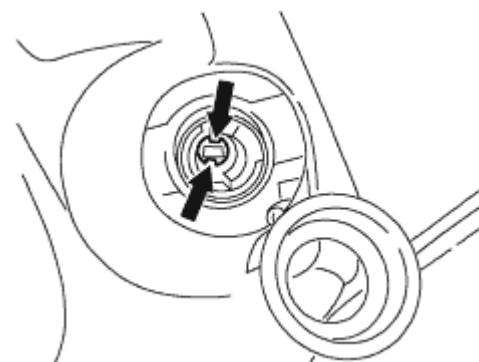



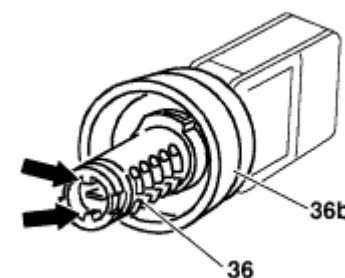



P46.10-0441-01



P46.10-0440-01

☒	Remove		
i	If the lock cylinder or key catches or binds, spray lock cylinder with lock cylinder grease	If the complaint cannot be rectified, the lock cylinder and key should be replaced	BR00.45-Z-1009-06A

1	Pull the transponder coil (L11) out of the lock cylinder using pulling hook	 Pulling hook	140 589 02 33 00
2	Push sleeve (011) onto cap (36b)	 Sleeve	202 589 00 14 00
3	Rotate lock cylinder into position "1" using the key and on further slightly to the next audible detent		
4	Unlock and remove lock cylinder by turning the cap (36b) counterclockwise through 90°		
	Install		
5	Spray outside of lock cylinder (36) with lock cylinder grease and insert into cap (36b)		BR00.45-Z-1009-06A
6	Push key through cap (36b) up to the stop in the lock cylinder (36)	 The tumblers must be fully retracted.	
7	Slide the lock cylinder (36) into the steering lock	 The lugs (arrow) in the lock cylinder (36) must align with the recesses in the steering lock (arrow).	
8	Turn cap (36b) with sleeve (011) clockwise through approx. 90° until it can be felt or heard to engage	 Sleeve	202 589 00 14 00
9	Turn key to position "0" and pull out/remove with sleeve (011)		
10	Press transponder coil (L11) onto the lock cylinder		

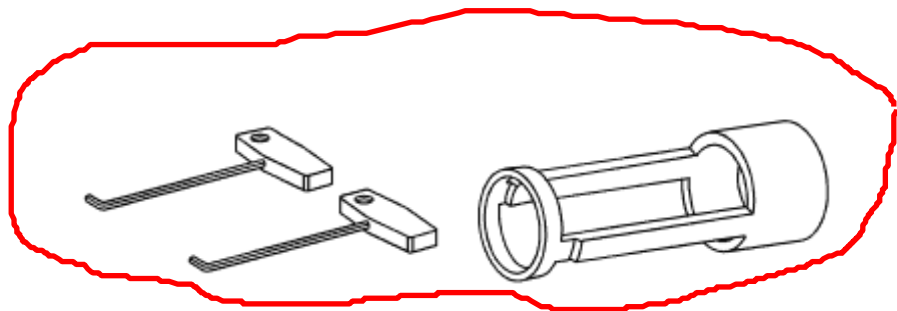

140 589 02 33 00

Pulling hooks

202 589 00 14 00

Sleeve

Repair products

Number	Designation	Order number
BR00.45-Z-1009-06A	Lock cylinder grease	001 989 26 51 10