

AR27.19-P-0230A	Replace pilot bushing in electrohydraulic control unit	3.2.05
-----------------	--	--------

TRANSMISSION 722.6 **Separate connector only when the transmission is cold.**

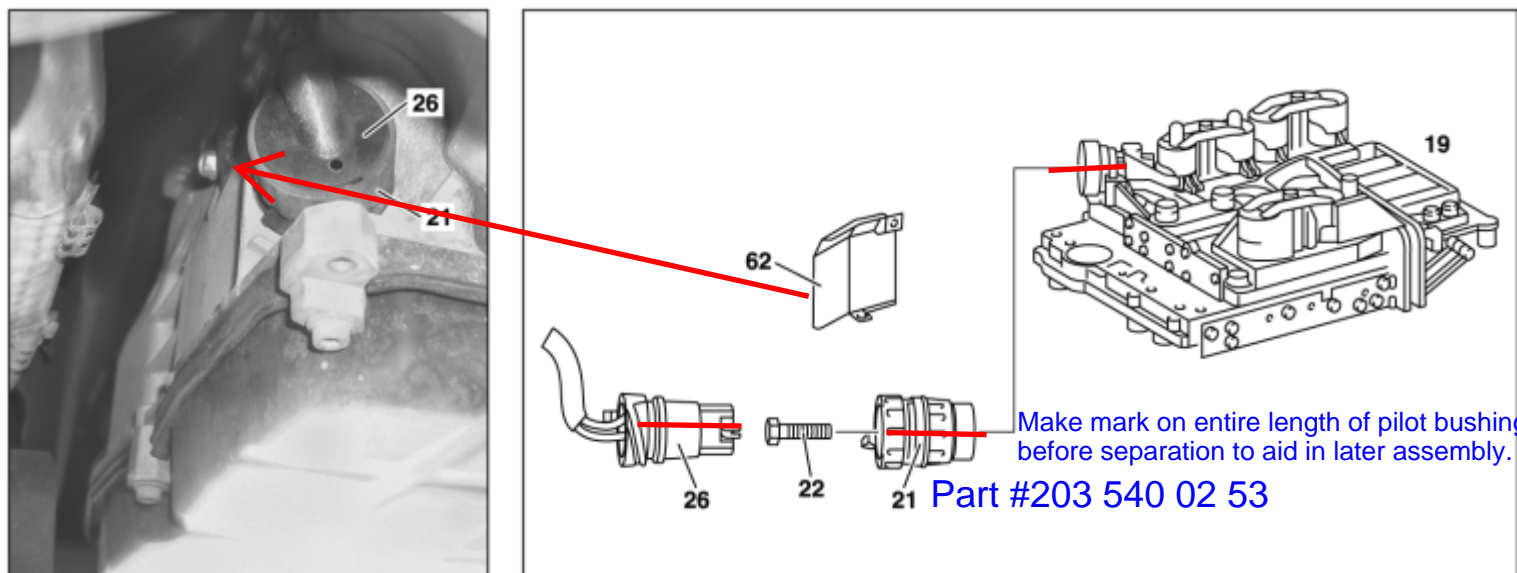

P27.19-2286-08

19 Electrohydraulic control unit
21 Pilot bushing

22 Bolt
26 Plug socket

62 Heat shield

	Remove/Install		
	Remove heat shield #62		
1.1	Switch off the ignition, remove the ignition key from the EIS control unit	Vehicles without Keyless Go	
1.2	Remove the Keyless Go transmitter (ignition key/card) from the vehicle and store beyond transmission range	Vehicles with Keyless Go Code 889	Switch off engine.
2.1	Remove the rear section of the engine compartment paneling	Model 163	AR61.20-P-1105GH
3.1	Disconnect plug connector (26)	Model 163	
			BA27.40-P-1014-01A
4	Unscrew bolt (22) and remove pilot bushing (21) from the electrohydraulic control unit (19)		When removing pilot bushing (21) watch for transmission oil run off.
			If there is a green dot on the pilot bushing (21), only the sealing rings have to be replaced and not the entire pilot bushing.
			BA27.19-P-1003-01A
5	Install in the reverse order		
6	Pour ATF into automatic transmission and inspect ATF level	Model 163	AR27.00-P-0101A

Electrohydraulic control unit

Number	Designation	Transmission 722.6
BA27.19-P-1003-01A	Bolt, pilot bushing to electrohydraulic control unit	3

Do not overtighten this bolt.

Housing

Number	Designation	Transmission 662/663/666/674

BA27.40-P-1014-01A	Bolt, heat shield to transmission housing		Nm	6
--------------------	---	--	----	---