

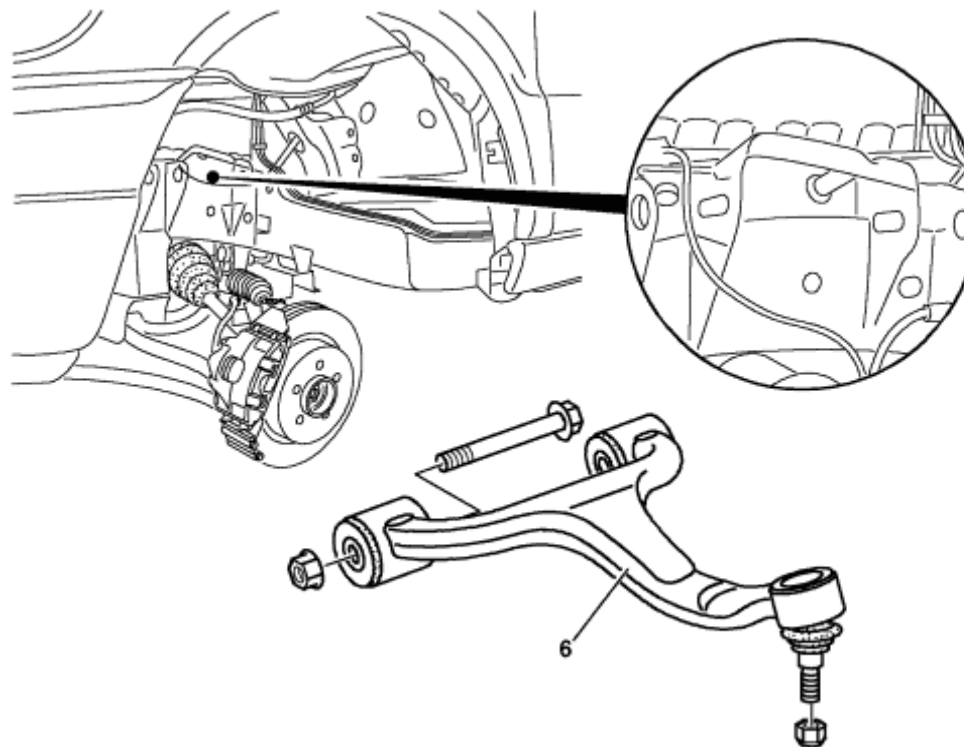









AR33.20-P-0500GH	Removing and installing upper wishbone	3.3.97
------------------	--	--------

MODEL 163



P33.20-0419-06

	Remove/install		
	Notes on self-locking nuts and bolts	All models	AH00.00-N-0001-01A
1	Remove front wheels		
	Remove, remount front road wheels,		AP40.10-P-4050GH

	rotate as necessary		
2	Remove shock absorber		AR32.25-P-0105GH
3	Detach brake line bracket from steering knuckle		
4	Use extractor to remove guide joint from upper control arm (6)		AR33.20-P-0500-01GH
	steering knuckle		BA33.20-P-1001-01D
		 Thrust piece	129 589 10 63 00
		 Support	163 589 01 43 00
		 Press	163 589 03 43 00
5	Secure steering knuckle to shock absorber with a wire to prevent it from tilting down	 To avoid leaks within the hydraulic brake system and open circuits in the electrical wiring, never tug on the brake lines or the electrical wiring.	
6	Detach upper transverse control arm (6) from vehicle frame	 Installation: Gently tighten the new nuts, continuing until they seat. Wait until the vehicle is resting on its road wheels before tightening the bolts.	
			BA33.20-P-1006-01D
7	Install in the reverse order		
8	Perform chassis alignment check		AR40.20-P-0200GH

 **Wheel location, hub**

Number	Designation	Model Series 163	
BA33.20-P-1001-01D	Self-locking nut, upper wishbone follower joint to steering knuckle	NM	50
BA33.20-P-1006-01D	Bolt, upper wishbone to frame	NM	120

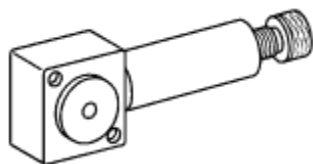

163 589 03 43 00

Press

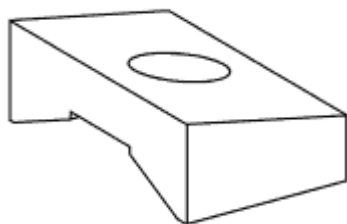

163 589 01 43 00

Support

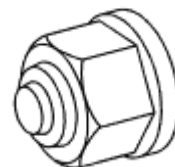

129 589 10 63 00

Thrust piece