

AR27.55-P-0100A

Flush out automatic transmission and converter

11.3.05

TRANSMISSION 722.6

93 Cap
 93a Plate
 93b Locking pin

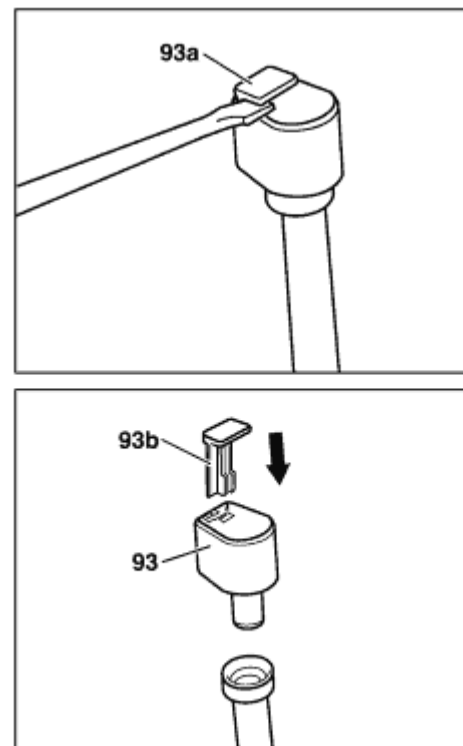

P27.00-2232-03

1 Oil cooling line connection
 2 Right oil cooling line
 3 Banjo bolt

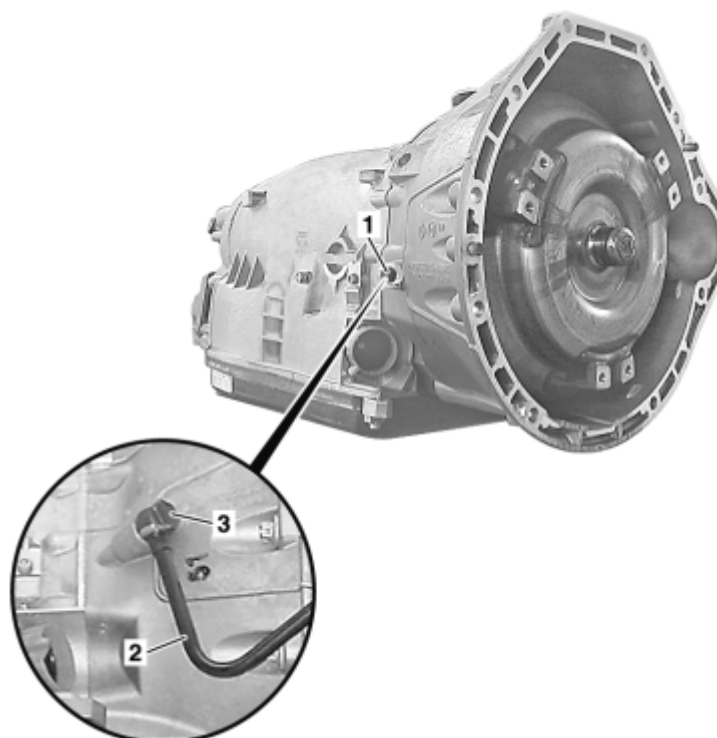























P27.55-2047-12

1 Oil cooling line connection
 2 Right oil cooling line
 3 Banjo bolt
 4 Connector
 5 Hose clamp



P27.55-2048-12

	Remove/install		
 Danger!	Risk of injury to skin or eyes from hydraulic fluid spraying out under pressure. Risk of poisoning from swallowing hydraulic fluid.	Depressurize the hydraulic system completely before starting any work on the system. Wear protective clothing and safety glasses.	AS00.00-Z-0013-01A
 Danger!	Risk of accident caused by vehicle starting off by itself when engine is running. Risk of injury caused by contusions and burns during starting procedure or when working near engine	Secure vehicle to prevent it from moving. Wear closed and snug-fitting work clothes. Do not grasp hot or rotating parts.	AS00.00-Z-0005-01A
 Danger!	Risk of death caused by vehicle slipping or toppling off of the lifting platform.	Align vehicle between lifting platform columns and position the four mounting plates on the lifting platform support points specified by the vehicle manufacturer.	AS00.00-Z-0010-01A
	Notes on self-locking nuts and bolts		AH00.00-N-0001-01A
	Before opening the hydraulic system the area surrounding the separation point should be cleaned thoroughly. Even the smallest dirt particles, introduced into the hydraulic components, can lead to malfunctions and a total failure of the hydraulic system		
1	Remove the rear section of the engine compartment paneling	Model 163.172/174/175	AR61.20-P-1105GH
2	Unscrew drain plug from the transmission oil pan and drain transmission oil	 The transmission oil should have an operating temperature of 80 °C.	
			BA27.10-P-1001-03A
3	Detach transmission oil pan and replace transmission oil filter	 Be careful when removing the transmission oil pan as approx. 2.5 liters of transmission oil are still in the transmission oil pan.	
4	Mount transmission oil pan	 Install new gasket.	
			BA27.10-P-1002-03A
5	Detach retaining clamps of right oil cooling line (2) from engine oil pan	 Model 163	BA27.55-P-1004-01A
6	Unscrew banjo bolt (3) from connection (1) of right oil cooling line (2)	 Model 163	BA27.55-P-1002-01A
7	Connect connection fitting (4) with an approx. 1.5 meter long hose using hose clamp (5)	 Take connection fitting (4) from  hand pump.	
			210 589 00 71 00
8	Mount banjo bolt (3) and oil cooling line (2) to connection fitting (4)		
9	Hold hose in a bucket with a scale	 The bucket should have a capacity of 10 liters.	
10	Unlock cap (93)	 Break off plate (93a) using a suitable tool and press out the locking pin (93b) remaining in the cap (93) downwards.	
11	Detach cap (93) from oil filler pipe		
12	 Fit funnel to oil filler pipe and pour 5 liters of oil into transmission	 14 liters of transmission oil are needed for the entire flushing process.	
			126 589 12 63 00
	Flushing		

i	An assistant is necessary for the flushing process.		
13	Start engine and allow transmission oil to run into bucket via hose	 Always observe work sequence and specifications for service products, otherwise the transmission can be damaged	
14	When 3 liters of transmission oil are in the bucket immediately turn off engine		
15	Add 3 liters of transmission oil		
16	Repeat flushing process twice		
17	Pour in remaining transmission oil (3 liters) and check transmission oil level	Model 163	AR27.00-P-0101A
18	Install in the reverse order		
19	Carry out engine test run, checking the transmission for function and oil leaks		

Nm Oil pan, automatic transmission

Number	Designation	Transmission 722.6	
BA27.10-P-1001-03A	Oil drain plug to oil pan	Nm	20
BA27.10-P-1002-03A	Bolt, oil pan to transmission housing	Nm	8
		4°	-

Nm Transmission, oil cooler

Number	Designation	Transmission 722.662/663/666/674		
BA27.55-P-1002-01A	Banjo bolt or union nut, oil cooler line to torque converter and transmission housing	1st stage	Nm	20
		2nd stage	4°	-
BA27.55-P-1004-01A	Bolt, clamp of oil cooler line to oil pan		Nm	8



126 589 12 63 00

Funnel

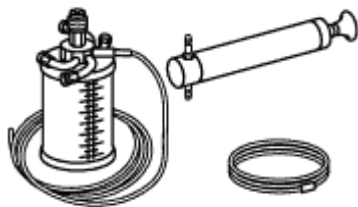

210 589 00 71 00

Hand pump