

**star bulletin****DTB**

Date: April 2001
Order No.: T-SI-47.10/13
Supersedes:
Group: 47

Revision:

**SUBJECT: Model 163.154/172/174
Installing supplemental lines for large capacity fuel filter with pressure regulator**

As part of Mercedes-Benz's on going commitment to quality, the fuel filter with pressure regulator will receive a product enhancement. Please perform this retrofit procedure on all vehicles within the Effective Serial Number Range table on page 2, at the vehicle's next service visit.

After this initial installation, the retrofitted fuel filter with pressure regulator need only be replaced for scheduled maintenance or faulty operation.

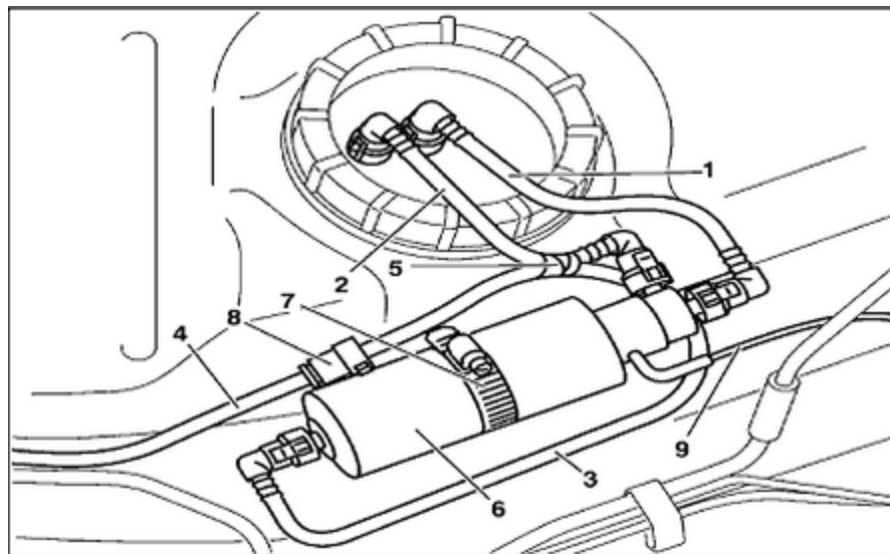

P47.20-2060-11

Figure 1

Effective Serial Number Range	Chassis End Number	
	From	To
163.154	-----	A 266446
163.172	-----	A 265965
163.174	-----	A 266484

RETROFIT PROCEDURE

A. Removal of existing fuel lines

1. Remove rear bolts on 2/3 bench seat and raise rear of seat.

Note: Applies only up to A 145272

2. Remove 60% rear seat, see WIS document: [AR91.12-P-1010GK](#).

Note: Applies only as of A 145273

3. Release and fold up left rear corner of front carpet until the cover for the fuel pump is exposed. Support carpet to prevent it from

folding back down.

4. Remove fuel pump cover, to ease removal use a hot air blower.

5. Using Special Tool 163 589 00 37 00, disconnect existing fuel lines (1, 2, Figure 1) from fuel pump. Discard fuel lines after disconnecting from the fuel pump.

Note: Failure to use Special Tool 163 589 00 37 00, when disconnecting fuel lines will result in a damaged connector, and a possible fuel leak when the new fuel line is connected.

B. Installation of Supplemental Fuel Lines

1. Connect new fuel feed line (1, Figure 1) from fuel pump (located underneath round cover) to filter (6, Figure1).
2. Connect new fuel feed return line (2, Figure 1) to fuel pump (located underneath round cover) from filter (6, Figure 1).
3. Connect fuel loop line (3, Figure 1) to engine fuel feed line (4, Figure 1) at connection (8, Figure 1).
4. Secure fuel loop line (3, Figure 1) via a cable tie (5, Figure 1) to the previously installed fuel feed return line (2, Figure 1).
5. Next place fuel filter with pressure regulator (6, Figure 1) into its bracket located on frame.
6. Move clamp (7, Figure 1) into center position of the filter with pressure regulator (6, Figure 1).

Note: Do not tighten clamp at this time.

7. Connect fuel feed line (1, Figure 1) as well as fuel return line (2, Figure 1) to filter with pressure regulator as shown in Figure 1.

B. Installation of Supplemental fuel lines (continued)

8. Connect fuel loop line (3, Figure 1) to forward end of filter with pressure regulator (6, Figure 1) as shown in Figure 1. Ensure that fuel loop line (3, Figure 1) is routed underneath rear of the fuel filter and that connection (8, Figure 1) is NOT compressed between the fuel filter and the fuel tank.

9. Attach vent hose (9, Figure1) to fuel filter with pressure regulator (6, Figure 1).

10. Adjust position of fuel filter with pressure regulator (6, Figure 1) on its bracket and then tighten clamp (7, Figure 1). Observe tightening torque on clamp.

Ensure that the fuel lines do not come in contact with the vehicle body or any other lines located on the vehicle frame.

11. Start engine and inspect fuel system for leaks. Shut off engine, and if necessary, find source of any fuel leaks and repair before starting next repair step.

12. Reinstall cover over fuel pump, using new body sealant.

13. Reinstall rear of carpet.

14. Lower the rear of 2/3 bench seat and secure with new bolts. Observe tightening torque on bolts.

Note: Applies only up to A 145272

15. Reinstall removed 60% rear seat, see WIS document: [AR91.12-P-1010GK](#).

Special Tools

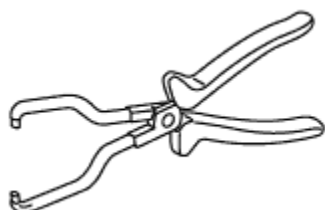

163 589 00 37 00
Pliers

Warranty Information (replacing fuel pump, supplemental lines and fuel filter)

Operation:

1. Install supplemental lines for large capacity fuel filter with pressure regulator with fuel pump replacement (02-3431).
2. Replace fuel pump (07-5730).

3. Replace fuel filter with pressure regulator (07-5563).

Damage Code	Operation Number	Labor Time (hrs.)	Model Indicator(s)
09-001 53	02-3431	0.2 hrs.	K0
	07-5730	1.7 hrs.	K0
	07-5563	0.9 hrs.	K1, K2, K3

Warranty Information (replacing only supplemental lines and fuel filter)

Operation:

1. Install supplemental lines for large capacity fuel filter with pressure regulator without fuel pump replacement (02-3432).

2. Replace fuel filter with pressure regulator (07-5563).

Damage Code	Operation Number	Labor Time (hrs.)	Model Indicator(s)
07-214 87	02-3432	0.5 hrs.	K0
07-214 87	07-5563	0.9 hrs.	K1, K2, K3

Parts Information

Qty.	Part Name	Part Number
1	Fuel feed line	163 470 28 64
1	Fuel return line	163 470 29 64
1	Fuel filter with pressure regulator	163 477 05 01
1	Fuel loop line	163 470 37 64
1	Cable tie	001 997 83 90