

MODEL 163.113 /128 /136 /154 /157 /172 /174 /175

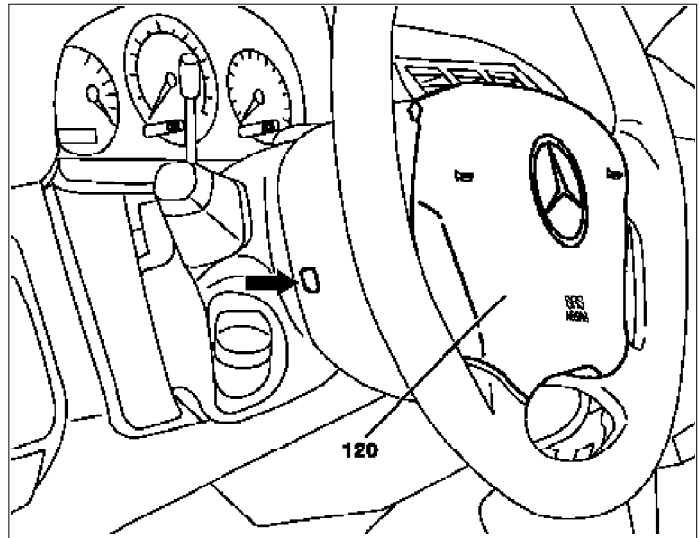

P46.10-0449-11

After removing bolt make mark on shaft and steer. wheel

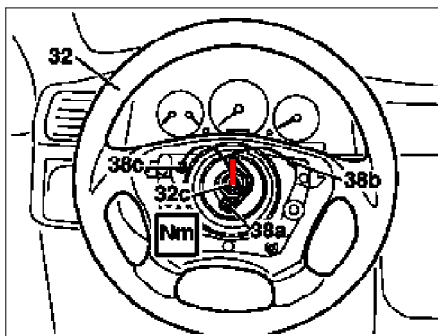

P46.10-0450-01

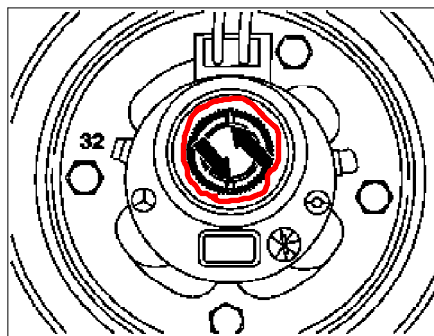

P46.10-0458-01

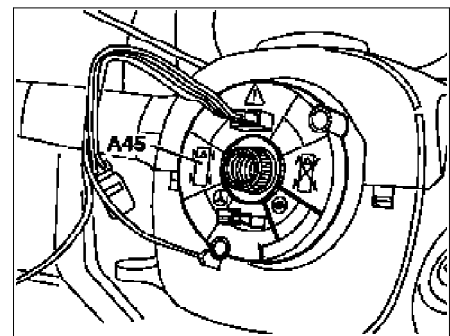

P46.10-0459-01

Modification notes

10.9.03	Connecting quiescent current retention unit deleted	Step 1	
10.9.03	Reference to adjusting toe on front axle replaced by reference to chassis alignment check	Step 10	

	Removing, installing			
	Danger!	Risk of explosion caused by explosive gas. Risk of poisoning and caustic burns caused by swallowing battery electrolyte. Risk of injury caused by burns to skin and eyes from battery acid or when handling damaged lead-acid batteries	No fire, sparks, open flames or smoking. Wear acid-resistant gloves, clothing and eye protection. Pour battery electrolyte only into suitable and appropriately marked containers.	AS54.10-Z-0001-01A
	Danger!	Risk of injury when carrying out test or repair work on airbag or emergency tensioning retractor units	Store airbag units with deployment side facing up; do not expose to temperatures greater than 100 °C. When working on these units, disconnect the power supply.	AS91.00-Z-0001-01A
		Legal provisions concerning handling and storage of airbag and emergency tensioning retractor units		AH91.00-P-0004-01A
		Notes on disposing of airbag and emergency tensioning retractor units		OS91.00-P-0001-01A
1		Disconnect ground cable from battery	Protect the ground cable to prevent unintentional contact with the battery ground terminal.	AR54.10-P-0003A
		Notes on battery		AH54.10-P-0001-01A
2		Remove airbag unit (120) from steering wheel (32) Remove 2 screws with #27 extended Torx socket		AR91.60-P-0660GH
		Instructions for performing repair, body work and welding on vehicles with airbags and ETR units		AH91.00-P-0002-01B
3		Unplug connectors (38b, 38c) for horn		
4		Turn steering wheel (32) to horizontal position (front wheels in straight-ahead position)		

5	Remove key and engage steering lock		
6	Unscrew bolt (32c)	<p>i Hold the steering wheel (32).</p> <p>i Installation: Replace bolt (32c).</p> <p>Nm</p>	*BA46.10-P-1001-02A
7	Pull off steering wheel (32) #10 Allen socket and at least a 3 ft. 1/2" breaker bar is needed.	<p>i Pass cables carefully through the openings.</p> <p>i Installation: Align recesses of the splines in the steering wheel with the markings on the steering shaft (arrows).</p>	
8	Check fanfare horns and airbag clock spring contact (A45) for damage	<p>! The clock spring contact must not be turned while the steering wheel is removed otherwise it will be damaged.</p> <p>! Visual inspection, replace clock spring contact if necessary: #</p> <p>Removing and installing clock spring contact</p>	<p>After removing the clockspring wrap tape around it so it doesn't move.</p> <p>AR46.10-P-0200GH</p>
9	Install in the reverse order		
10	Carry out road test	! Tests during the road test:	
		<p>Turn signal canceling:</p> <p>i When the steering wheel is offset by more than 1 tooth, satisfactory resetting of the turn signal is no longer guaranteed.</p> <p>Airbag indicator lamp:</p> <p>i The SRS indicator lamp must not light up on full steering lock in both directions.</p> <p>Steering wheel position:</p> <p>i If the steering wheel is crooked, adjust it by max. 1 tooth. If the difference is greater: #</p> <p>Check toe on front axle and adjust if necessary, see: #</p> <p>Performing chassis alignment check</p>	AR40.20-P-0200A

Nm **Steering wheel**

Number	Designation	Model 163
BA46.10-P-1001-02A	Bolt, steering wheel to steering shaft Nm	80