

AR46.10-P-0200GH	Removing, installing contact spiral	1.3.97
------------------	-------------------------------------	--------

MODEL 163

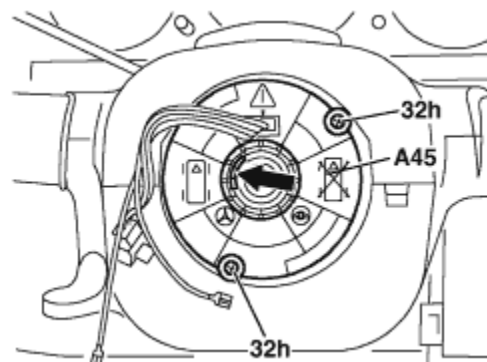

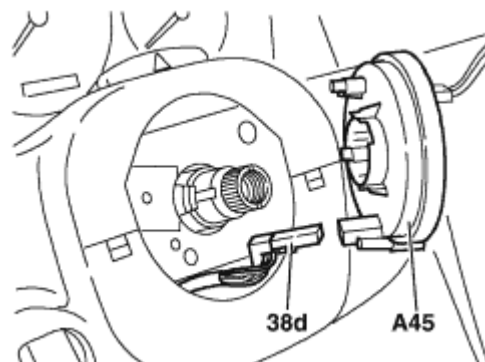



P46.10-0460-01

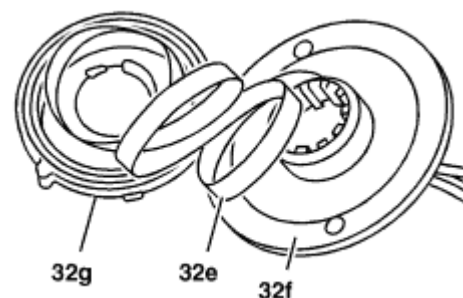



P46.10-0461-01



P46.10-0399-01

	Remove/install		
1	Remove steering wheel	 Front wheels centered	AR46.10-P-0100GH
2	Only unscrew the mounting screws (32h) until the fanfare horns and airbag clock spring contact (A45) can be removed	 The fastening bolts also act as protection against twisting and as an assembly aid.	
3	Remove the fanfare horns and airbag clock spring contact (A45) carefully from the jacket tube	 Installation: Push on fanfare horns and airbag clock spring contact (A45) as far as the stop. In the process the recess must align with the fixing lug (arrow)	
		 If the clock spring contact twists out of position, i.e., if the steering joint is removed: ↓	
		Set the clock spring contact to center position	AR46.10-P-0200-01GH

4	Unlock plug and disconnect the connector (38d) from the fanfare horns and airbag clock spring contact (A45)		
5	Check fanfare horns and airbag clock spring contact (A45) for damage	 Visual inspection	
		 Do not use any oil or grease!	
		 The upper (32f) and lower part (32g) of the clock spring contact are clipped together and can only be separated by the effect of high forces or due to defective assembly. If the spring contact is assembled incorrectly, carefully unwind and clip the upper and lower parts together. Be careful not to trap or bend the spring contact (32e).	
6	Install in the reverse order		