

AR32.20-P-0200GH	Remove/install front spring	19.2.97
------------------	-----------------------------	---------

MODEL 163

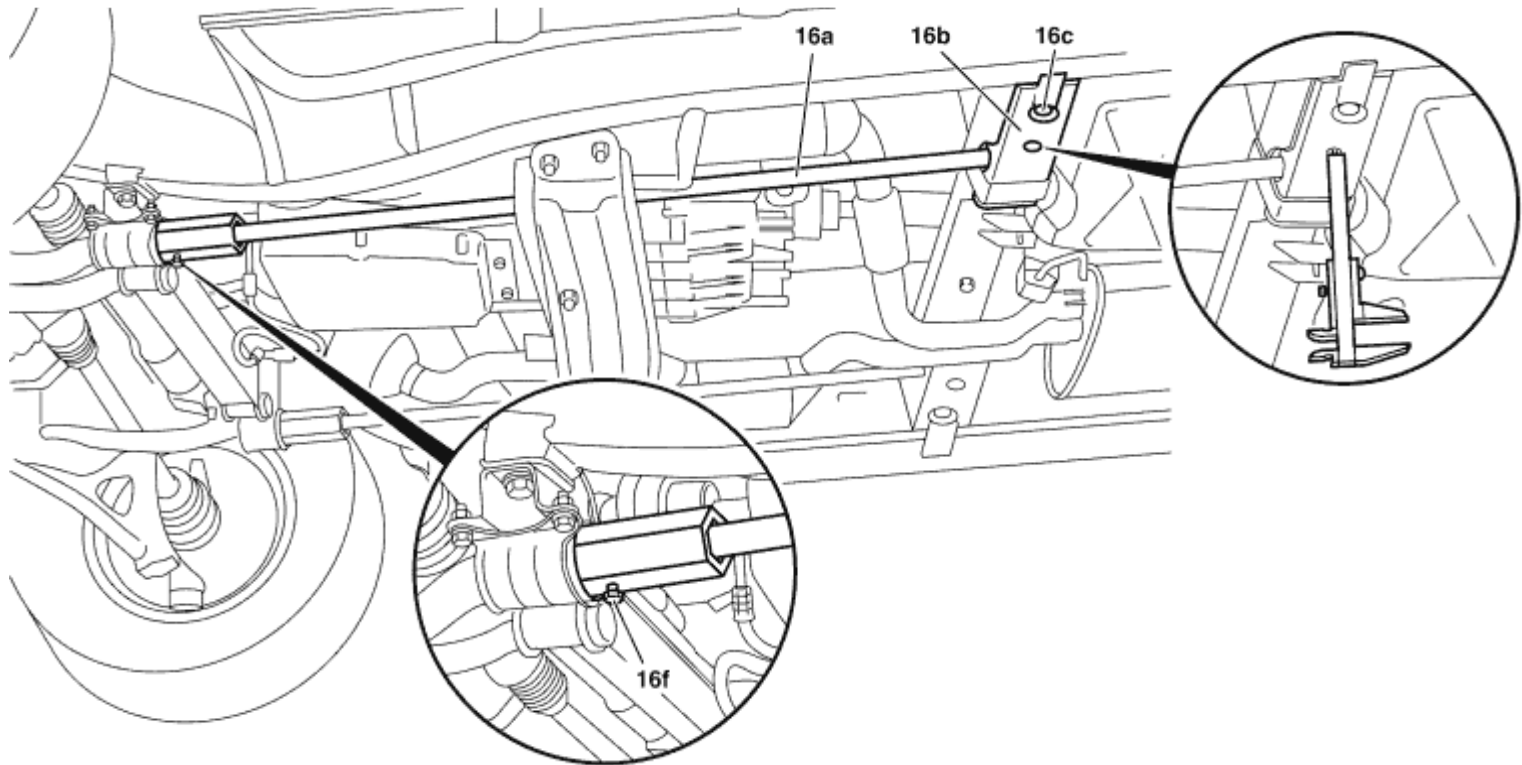

P32.25-0254-09

16a Torsion bar spring
16b Counterplate

16c Bolt
16f Bolt

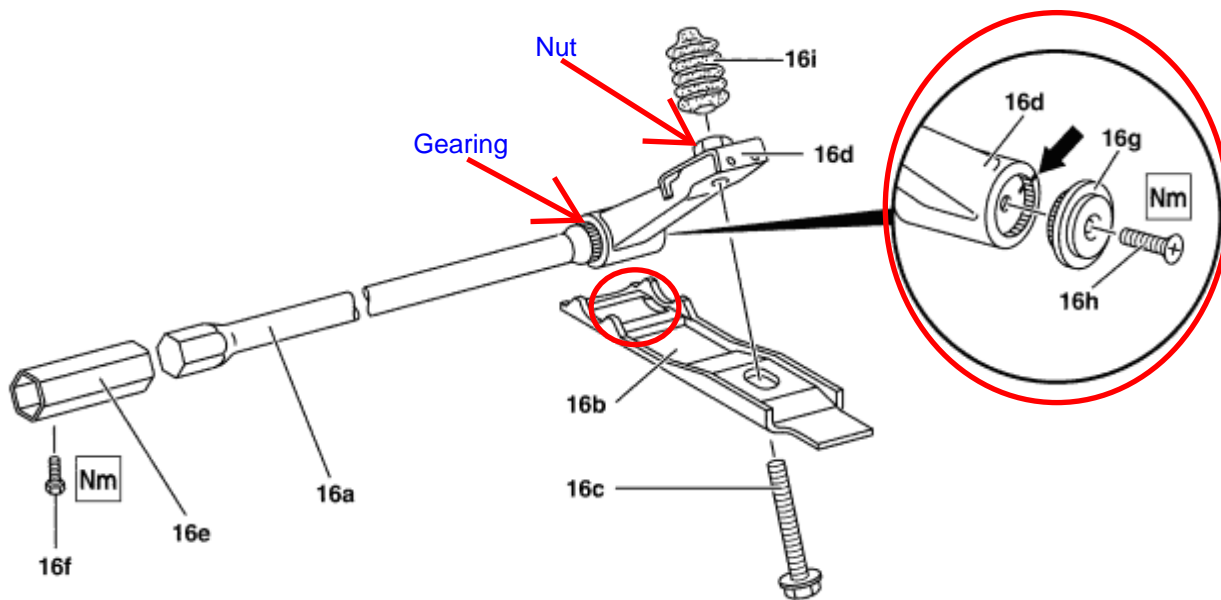

P32.20-0273-08

16a Torsion bar spring
16b Counterplate
16c Bolt

16d Clamping lever
16e Profile sleeve
16f Bolt

16g End cover
16h Bolt
16i Rubber bellows

	Remove, Install		
Danger!	Risk of fatal accident from vehicle slipping or toppling off the lift platform		Align vehicle between the columns of lifting platform and position the four support plates below the support strong points specified by the vehicle manufacturer. AS00.00-Z-0010-01A
✓ 1	Jack up vehicle. Front wheels must be off ground. Do not place jack or jack stands under control arms.		Use jacking points.
✓ 2	Measure spring preload of torsion bar spring (16a) using caliper gage at bore		Installation: Restore spring preload.

To replace plastic bearing (red circle) just follow steps 1-3. Part #163 323 02 20. Two needed

✓ 3	Unscrew bolt (16c) and then release tension of torsion bar spring (16a).	i Installation: regrease bolt (16c). The rubber bellows (16i) must be filled with grease.	BR00.45-Z-1016-06A
4	Undo bolt (16f) in profile sleeve (16e).	Nm ??Possibly only for 98-99??	BA32.20-P-1001-01A
5	Slide back profile sleeve (16e).		
6	Remove torsion bar spring (16a).	i Installation: The position of the torsion bar spring (16a) relative to the clamping lever (16d) is indicated (arrow).	
7	Loosen bolt (16h). Remove end cover (16g).	Nm	BA32.20-P-1002-01A
8	Remove torsion bar spring (16a) from clamping lever (16d).	i Installation: Grease gearing on torsion bar spring. Observe markings.	BR00.45-Z-1016-06A
9	Install in the reverse order		
10	Check vehicle level at front and rear axles with electronic inclinometer and adjust if necessary.		AR40.20-P-0301GH
11	Check and correct headlamp adjustment		
 WAP	Check and correct headlamp adjustment		AP82.10-P-8260GH

Nm Steel spring suspension of front axle

Number	Designation		Model 163
BA32.20-P-1001-01A	Bolt on profile sleeve	Nm	23
BA32.20-P-1002-01A	Bolt in end cover	Nm	≈23

Auxiliary repair materials

Number	Designation	Order number
BR00.45-Z-1016-06A	Optimol grease	A 000 989 76 51