

P32.25-0254-09

16a Torsion bar spring
16b Counterplate

16c Screw
16f Screw

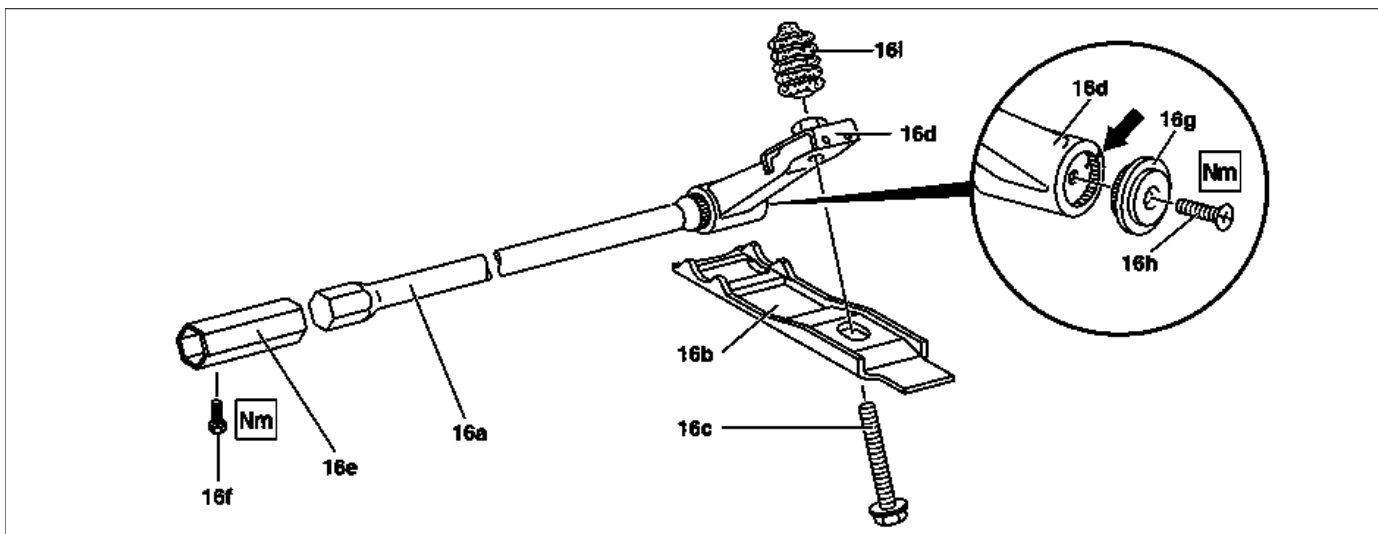





P32.20-0273-08

16a Torsion bar spring
16b Counterplate
16c Screw

16d Clamping lever
16e Profile sleeve
16f Screw

16g End cover
16h Screw
16i Rubber bellows

	Remove/install		
<p>⚠ Danger!</p>	<p>Risk of death caused by vehicle slipping or toppling off of the lifting platform.</p>	<p>Align vehicle between the columns of the lifting platform and position the four support plates at the lifting platform support points specified by the vehicle manufacturer.</p>	<p>AS00.00-Z-0010-01A</p>
<p>1</p>	<p>Raise vehicle</p>		
<p>2</p>	<p>Measure initial spring tension of torsion bar spring (16a) using vernier caliper on bore</p>	<p>i Installation: Restore initial spring tension.</p>	
<p>3</p>	<p>Unscrew bolt (16c) and relieve pressure on torsion bar spring (16a)</p>	<p>i Installation: Grease bolt (16c) again. Rubber bellows (16i) must be filled with grease.</p>	<p>*BR00.45-Z-1005-06A</p>
<p>4</p>	<p>Release bolt (16f) from profile sleeve (16e)</p>	<p>Only up to model year 1999</p> <p>Nm</p>	<p>*BA32.20-P-1001-01A</p>
<p>5</p>	<p>Slide back profile sleeve (16e)</p>	<p>i Sluggishness through soiling possible.</p>	

6	Remove torsion bar spring (16a)	 Installation: Position of torsion bar spring (16a) marked relative to clamping lever (16d) (arrow).	
7	Undo bolt (16h). Remove end cover (16g)		*BA32.20-P-1002-01A
8	Pull torsion bar spring (16a) out of clamping lever (16d)	 Installation: Grease components.  Installation: Observe markings.	*BR00.45-Z-1005-06A
9	Install in the reverse order		
10	Check vehicle level at front and rear axle with electronic inclinometer and adjust if necessary		AR40.20-P-0301GH
11	Check and correct the adjustment of the headlamps  AP Check and correct the adjustment of the headlamps		AP82.10-P-8260GH

 **Front axle steel suspension**

Number	Designation		Model 163
BA32.20-P-1001-01A	Bolt to profile sleeve	Nm	23
BA32.20-P-1002-01A	Bolt to end cover	Nm	≈23

Repair materials

Number	Designation	Order number
BR00.45-Z-1005-06A	Paste, hot lubrication 1 kg, DB supply specification 6879.20	A 000 989 76 51