

MODEL 163.113 /128 /136 /154 /157 /172 /174 /175 with CODE (221b) Electrically adjustable driver and passenger seat

- 1 Torx socket screws
- 2 Cover cap
- 3 Front seat
- 4 Torx socket bolt
- 5 Belt end fitting
- 6 Connector
- X55/3 Left front seat contacting strip
- X55/4 Right front seat connector block

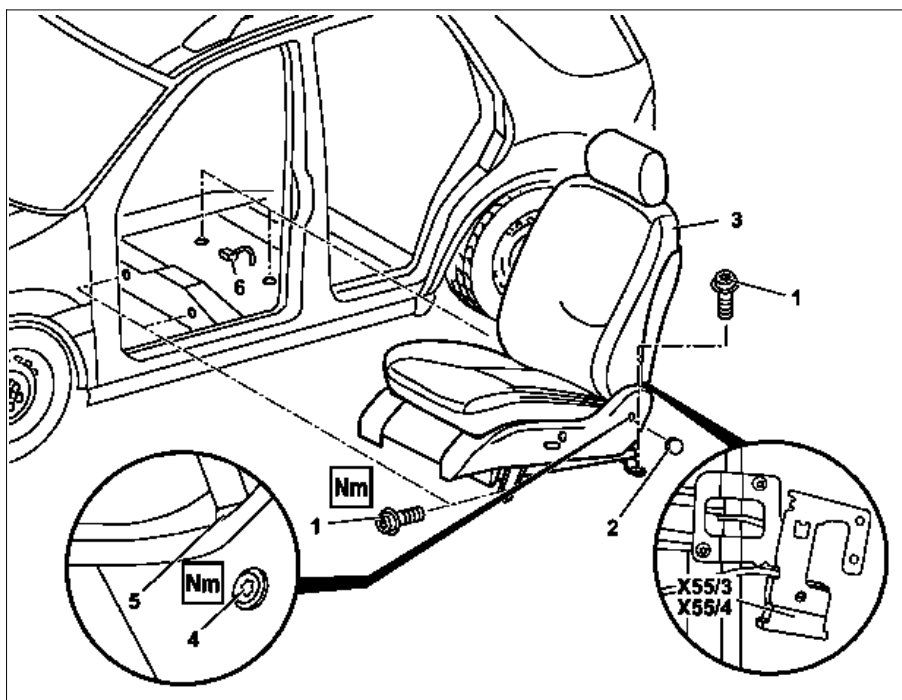

P91.10-0547-06

	Remove/install		
1	Remove headrest	See owner's manual	
2	Remove cover cap (2) from seat rail paneling	Set the seat height adjustment such that the screw on the belt end fitting is visible.	
3	Unscrew internal Torx drive bolt (4) from the belt end fitting (5)	 Torx bit set	*BA91.40-P-1001-01D *000589011000
4	Remove belt end fitting (5)		
5	Unscrew internal Torx drive bolts (1) from the front seat console	Installation: Replace bolts. Torx bit set	*BA91.10-P-1001-01B *000589011000
6	Move the front seat (3) forward		
7	Unscrew internal Torx drive bolts (1) from the back seat console	Installation: Replace bolts. Torx bit set	*BA91.10-P-1001-01B *000589011000
8	Detach connector (6) from the front left seat connector block (X55/3) and the front right seat connector block (X55/4)		
9	Remove front seat (3)		
10	Install in the reverse order		

Front seats

Number	Designation		Model Series 163
BA91.10-P-1001-01B	Bolt of seating mounting bracket to vehicle floor	Nm	40

Safety belts/emergency tensioning retractors

Number	Designation	Model 163 up to 08/99	Model 163 as of 09/99
BA91.40-P-1001-01D	Belt end fitting screw	Nm 35	35

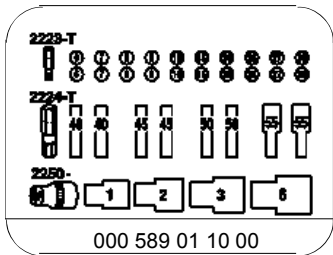

Torx bit set