

GF83.55-P-2101-03GH

Electromagnetic clutch, design

 GF

The belt pulley (1) mounted on the drive shaft (4) of the refrigerant compressor is driven by the poly V-belt. It rotates on the ball bearing (3), around the solenoid (5) attached on the refrigerant compressor housing. The pressure plate (6) with the rubber insert (7) is connected via splining (8) to the drive shaft (4) of the refrigerant compressor and is axially displaceable thereon.

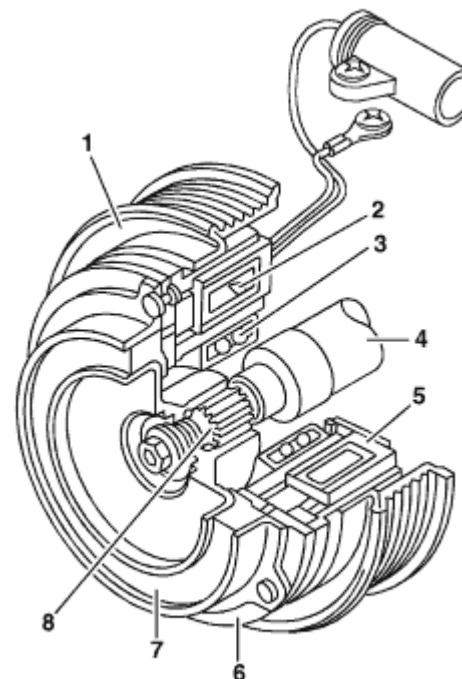

P83.55-0212-03