

- ENGINE 112.945 in MODEL 463.209 /232 /233 /244 /245 /250
- ENGINE 112 in MODEL 129, 163, 170, 202, 203, 208, 209, 210, 220
- ENGINE 113.962 in MODEL 463.206 /240 /241 /247 /248 /249 /254
- ENGINE 113 in MODEL 129, 163, 202, 208, 209, 210, 211.076 /276, 215, 220, 230.474 /475
- ENGINE 137 in MODEL 215, 220
- ENGINE 112.913 in MODEL 211.061 /261
- ENGINE 112.949 in MODEL 211.065 /265
- ENGINE 113.967 in MODEL 211.070 /270
- ENGINE 113.987 in MODEL 209.376
- ENGINE 113.982 in MODEL 463.243 /246
- ENGINE 112.917 in MODEL 211.080 /280
- ENGINE 112.954 in MODEL 211.082 /282
- ENGINE 113.969 in MODEL 211.083 /283

Shown on engine 112 with manual transmission

- 1 Flywheel with starter ring gear
- 2 Washer
- 3 Bolts
- 4 Cylinder pin
- 5 Crankshaft
- 6 Retaining lock

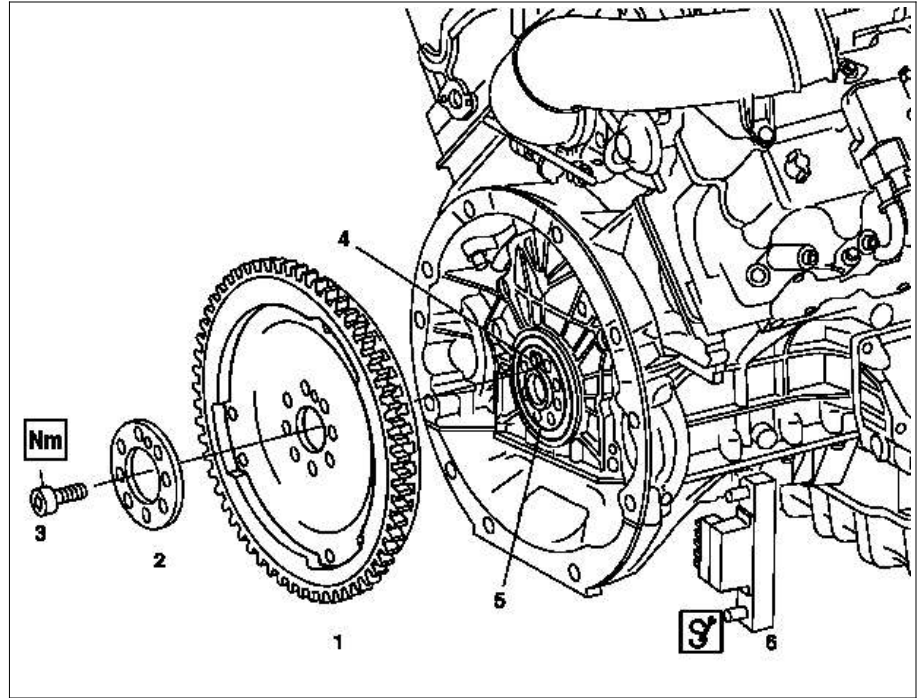

P03.30-0283-06

**Modification notes**

5.7.11	Value modified: Bolt, pressure plate to flywheel or two-mass flywheel	*BA25.10-P-1001-01A
--------	---	---------------------

		<b>Remove/install</b>	
☒ ☒		<b>Risk of death</b> caused by vehicle slipping or toppling off the lifting platform.	Align vehicle between columns of lifting platform and position the four support plates at lifting platform support points specified by vehicle manufacturer. <span style="color: red;">AS00.00-Z-0010-01A</span>
1.1	Remove automatic transmission	Model 129, 170, 202, 208, 210 Model 463 Model 463 Model 230.474 /475 Model 215, 220 without 4MATIC with engine 112, 113 Model 220, 211 with 4MATIC with engine 112, 113 Model 215, 220 with engine 137 Model 203 without 4MATIC, 209 with engine 112, 113 Model 203 with 4MATIC Model 211 without 4MATIC with engine 112, 113 Model 163 with engine 112, 113	AR27.10-P-0500B AR27.10-P-0500BD AR27.10-P-0500GA AR27.10-P-0500R AR27.10-P-0500I AR27.10-P-0500IW AR27.10-P-0500I AR27.10-P-0500P AR27.10-P-0500PW AR27.10-P-0500T <span style="color: red;">AR27.10-P-0500GH</span>
1.2	Remove manual transmission	Model 210, 202, 129 with engine 112 Model 203, 209 with engine 112 Model 211 with engine 112 Model 170	AR26.10-P-0020A AR26.10-P-0020P AR26.10-P-0020T AR26.10-P-0020D

1.3	Remove Sequentronic automated manual transmission (AMT)	Model 203, 208, 209.3 with engine 112 Model 211.0 with engine 112	AR26.10-P-0020E AR26.10-P-0020TA
2	Install retaining lock (6) for crankshaft (5) and starter ring gear		AR03.30-P-5000B
3.1	Detach clutch	Vehicles with manual transmission <b>i</b> Only unscrew or screw in bolts by 1 to 1.5 turns at a time Model 129, 163, 170, 202, 208, 210 Model 203, 209, 211 <b>Nm</b> Bolt, pressure plate to flywheel or two-mass flywheel	AR25.10-P-0050A AR25.10-P-0050P *BA25.10-P-1001-01A
4	Remove bolts (3) of flywheel or of drive plate	<b>i</b> <b>Installation:</b> Replace bolts, because if they are used again, the connection may loosen and the bolts may shear off. <b>Nm</b> Torx bolts of two-mass flywheel/driven plate at crankshaft	*BA03.30-P-1002-01D
5	Remove washer (2)		
6	Remove flywheel with starter ring gear (1) and drive plate  GF Flywheel, two-mass flywheel, drive plate, location	<b>i</b> <b>Installation:</b> The cylinder pin (4) determines the installation position. Engine 112, 113	GF03.30-P-8001-01B
7	Install in the reverse order		
8	Carry out initialization	<b>i</b> If a new flywheel or drive plate is installed, perform initialization in ME control unit with STAR DIAGNOSIS in menu item "Control unit adaptation". STAR DIAGNOSIS diagnosis system	

**Nm** Flywheel, driven plate, vibration damper, starter ring gear

Number	Designation	Engine 112		
BA03.30-P-1002-01D	Bolt, two-mass flywheel/drive plate to crankshaft	Stage 1	Nm	45
		Stage 2	⌘°	90

**Nm** Flywheel, driven plate, vibration damper, starter ring gear

Number	Designation	Engine 113.94/96/97/98			Engine 113.990/991/992/993/995	Engine 137
BA03.30-P-1002-01D	Bolt, two-mass flywheel/drive plate to crankshaft	Stage 1	Nm	45	45	45
		Stage 2	⌘°	90	90	90

**Nm** Clutch

Number	Designation	Model 129, 140, 163, 170, 202, 203, 208, 209, 210, 211, 230	Model 461, 463

BA25.10-P-1001-01A	Bolt of pressure plate to flywheel or two-mass flywheel	Stage 1	Nm	16	16
		Stage 2	Nm	25	25