

ENGINE 112 in MODELS 170, 208, 202, 210, 209, 203

ENGINE 113 in MODELS 163.174 /175, 209.375 /475

ENGINE 113.987 in MODELS 209.376 /476 up to 23.4.04

Shown on engine 112

- 1 Electric fan
- 2 Fan shroud
- 3 Poly-V-belt
- 5 Timing case cover
- 6 Chain tensioner
- 7 Sealing ring
- G2 alternator

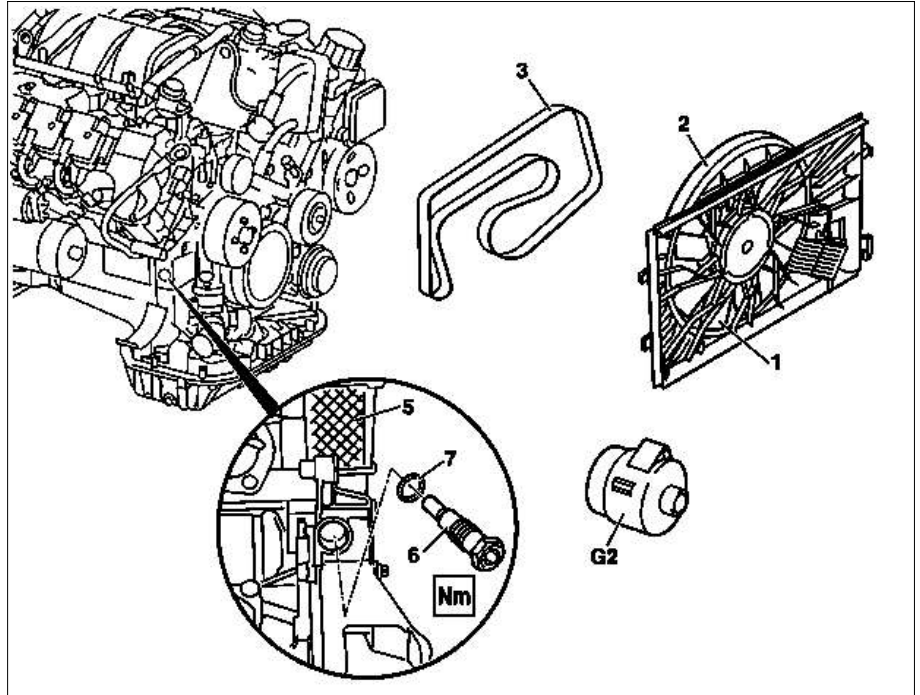

P05.10-2102-06

☒ ☒	Remove/install		
1.1	Remove fan shroud (2) together with electric fan	Models 208, 210 with engine 112	
1.2	Remove electric fan (1)	Model 170.465 with engine 112.947 Model 170.466 with engine 112.960 Models 203.061 /261 with engine 112.912 Models 203.064 /264 /764 with engine 112.946 Models 203.065 /265 with engine 112.961 Models 203.081 /281 with engine 112.916 Models 203.084 /284 with engine 112.953 Models 209.361 /461 with engine 112.912 Models 209.365 /465 with engine 112.955 Models 209.375 /475 with engine 113.968 Models 209.376 /476 with engine 113.987 Model 163.174 with engine 113.981 Model 163.175 with engine 113.965	AR20.40-P-5000SV AR20.40-P-5000PV AR20.40-P-5000GH
2.1	Remove alternator (G2)	<p>i On alternator (G2) only unscrew upper bolt, slacken lower bolt. Fold away the alternator (G2).</p> Models 202.088, 210.061 /062 /261 /262 Models 163.174 /175 with ENGINE 113 Model 170 with Engine 112 Models 203.061 /261 with engine 112.912 Models 203.064 /264 /764 with engine 112.946 Models 203.065 /265 with engine 112.961 Models 209.361 /461 with engine 112.912 Models 209.365 /465 with engine 112.955 Models 209.375 /475 with engine 113.968 Models 209.376 /476 with ENGINE 113.987 Models 203.081 /084 /281 /284 with engine 112 Model 202 with engine 112.910 /920, except 202.088 with engine 112 Model 208 with engine 112.940, 113.943 /984 Model 210 with engine 112.921 /941, except 210.061 /062 /261 /262 with engine 112 Models 210.061 /062 /261 /262 Model 202.088 <p>S External Torx set</p>	AR15.40-P-5032GH AR15.40-P-5032G AR15.40-P-5032P AR15.40-P-5032PW AR15.40-P-5032EB AR15.40-P-5032ED *001589760900

3	Remove chain tensioner (6) from timing case cover (5)	i Installation: Replace seal (7). Nm Engine 112 Nm Engine 113 Engine 112, 113	*BA05.10-P-1001-01C *BA05.10-P-1002-01B GF05.10-P-7801-01A
4	Design of chain tensioner	Install in the reverse order	

Nm Timing chain, chain tensioner

Number	Designation	Engines
BA05.10-P-1001-01C	Chain tensioner in timing case cover	Nm 80 112.910/911/ 912/913/914/ 915/916/917/ 920/921/922/ 923/940/941/ 942/943/944/ 945/946/947/ 949/951/953/ 954/955/960/ 961/970/972/ 973/975/976

Nm Timing chain, chain tensioner

Number	Designation	Engine
BA05.10-P-1002-01B	Chain tensioner housing in timing case cover	Nm 80 113.940/941/ 942/943/944/ 948/960/961/ 962/963/964/ 965/966/967/ 968/969/971/ 980/981/982/ 984/986/992/ 993/995

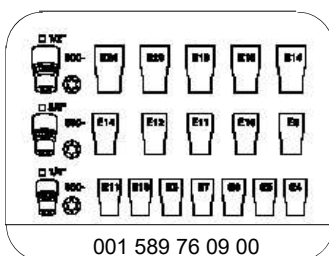

001 589 76 09 00

External Torx set