

# 2001 Mercedes-Benz ML320

2001 SYSTEM WIRING DIAGRAMS Mercedes-Benz - ML320

## Starting Circuit

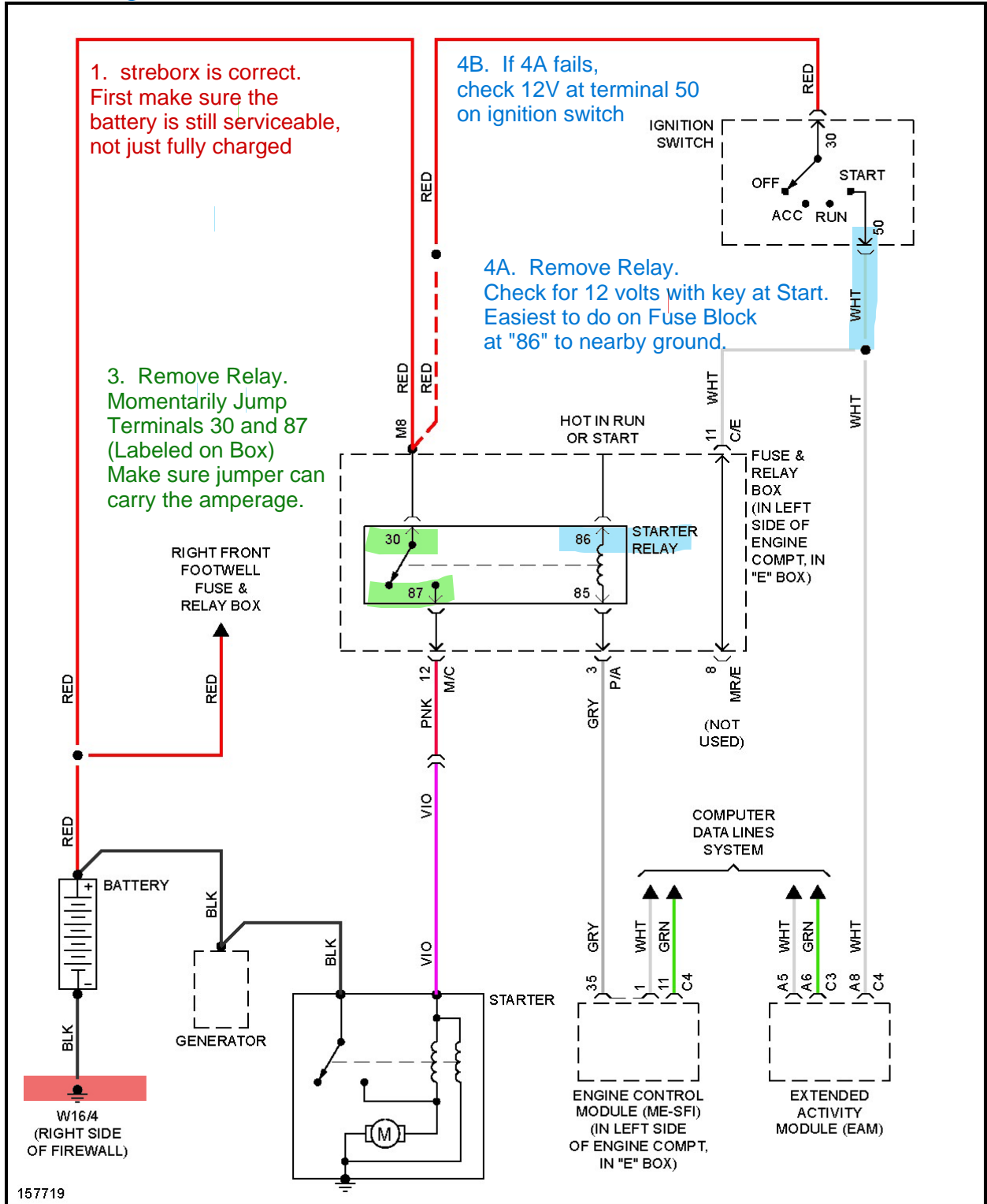

2. Not likely the cause, but check for 0 ohms from battery negative to another point on chassis