

ENGINES 272, 273 in MODEL 164

ENGINES 272, 273, 276 in MODEL 251

Shown on model 251 with engine 272

- 1 Coolant expansion reservoir
- 2 Cap
- 3 Right cylinder crankcase drain screw
- 4 Left cylinder crankcase drain screw
- 5 Drain plug of radiator
- 6 Fitting

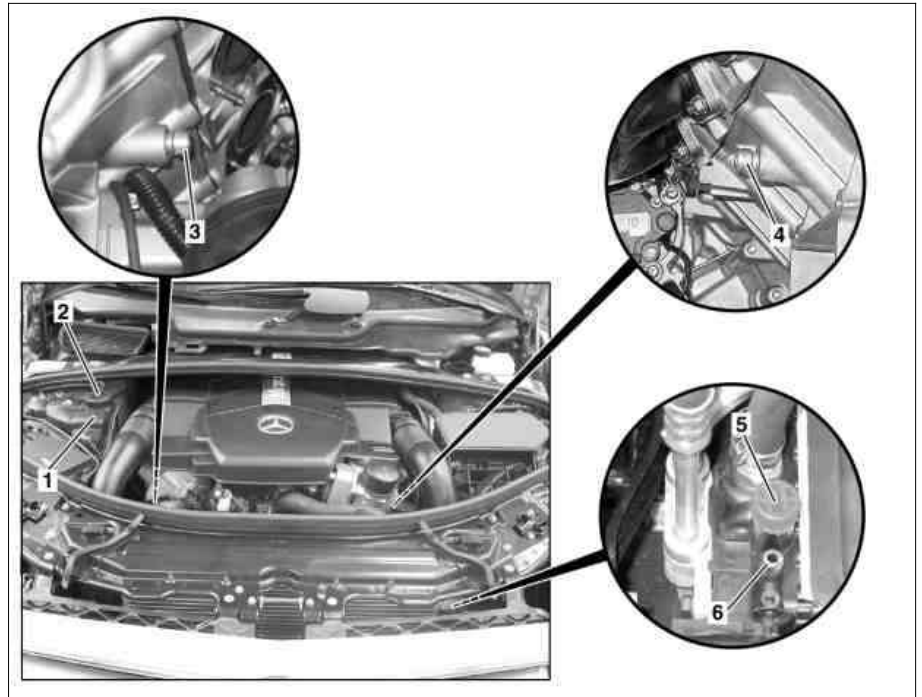

P20.00-2290-06

## Engine 276

- 7 Coolant pump drain screw
- 8 Coolant pump
- 9 Drain hose

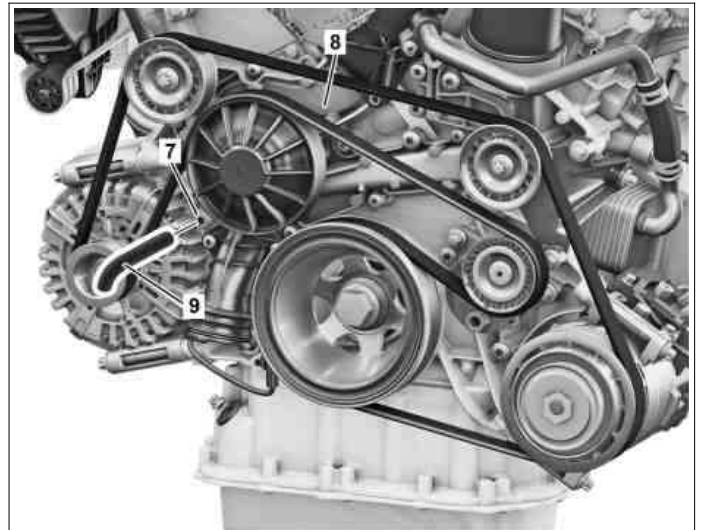

P20.00-2434-11

	Drain		
<b>⚠ Danger!</b>	<b>Risk of explosion</b> caused by escaping oxyhydrogen gas. <b>Risk of injury</b> caused by caustic burns to eyes, skin and mucous membranes from battery electrolyte (contains diluted sulfuric acid) or metal spatter due to short circuit. <b>Risk of burn injuries</b> caused by short circuit. <b>Risk of poisoning</b> caused by swallowing battery electrolyte (contains diluted sulfuric acid) or absorption of lead over the skin or orifices	No fire, sparks, open flames or smoking. Wear acid-resistant gloves and clothing and safety glasses with side guards. Do not place any conductive objects on the battery and avoid any short circuit from battery positive to ground. Only fill liquid battery electrolyte (diluted sulfuric acid) into suitable and appropriately marked containers.	AS54.10-Z-0001-01A
<b>⚠ Danger!</b>	<b>Risk of injury</b> to skin and eyes caused by scalding from contact with hot coolant spray. <b>Risk of poisoning</b> caused by swallowing coolant.	Do not open cooling system unless coolant temperature is below 90°C. Open cap slowly and release the pressure. Do not pour coolant into beverage containers. Wear protective gloves, protective clothing and safety glasses.	AS20.00-Z-0001-01A
1	Unscrew cap for coolant expansion reservoir (1)	<b>i</b> Unscrew cap slowly and relieve excess pressure.	
2	Remove bottom engine compartment paneling	Model 164	AR61.20-P-1105GZ

		Model 251	AR61.20-P-1105RT
	<b>Drain coolant from radiator</b>		
3	Slide collector siphon hose onto fitting (6) at radiator	The fitting (6) is located at bottom left of the radiator.	
4	Loosen siphon hose (5) at radiator and drain coolant.	Observe regulations for disposal of coolant.	
	<b>Drain coolant at cylinder crankcase or coolant pump</b>		
5	Detach ground line from battery	Engine 272, 273 When draining the coolant at the right drain plug (3) on the crankcase Model 164 Model 251	AR54.10-P-0003GZ AR54.10-P-0003RT AH54.10-P-0001-01A
	Notes on battery		
6.1	Loosen right or left drain plug (3 or 4) at crankcase until it can be turned manually	Engine 272, 273	
6.2	Loosen drain screw (7) on coolant pump (8) until it can be turned by hand	Engine 276	
7.1	Push drain hose on right or left drain plug (3 or 4) onto crankcase	Engine 272, 273	
7.2	Push drain hose (9) onto drain screw (7)	Engine 276	
8	Unfasten drain screw (3 and 4 or 7) on cylinder crankcase or coolant pump further by hand and drain off coolant	Follow regulations for disposal of coolant.	
	<b>Filling</b>		
9	Tighten drain plug (5) at radiator and detach siphon hose from fitting (6)		
10.1	Disconnect the siphon hose and tighten the drain plug (3, 4) at crankcase	Engine 272, 273 	*BA20.00-P-1001-02E
10.2	Detach drain hose and tighten drain screw (7) at coolant pump (8)	Engine 276 	*BA20.10-P-1008-01AA
11	Pour in coolant and bleed cooling system	Reuse clean coolant.  	AR20.00-P-1142-04A *210589009100 *285589002100 AH20.00-P-1142-01GZB AH20.00-N-2080-01A BB00.40-P-0310-01A BB00.40-P-0325-00A *BF20.00-P-1001-04A
	Notes on coolant level		
	Notes on coolant		
<b>BB</b>	Coolant specifications	Sheet 310.1	
<b>BB</b>	Anticorrosion/antifreeze agents (Sheet 325.0)	Sheet 325.0 	
12	Inspect cooling system for leaks		AR20.00-P-1010GZC
13	Attach ground lead to battery	After tightening crankcase drain plug on the right (3). Model 164 Model 251	AR54.10-P-0003GZ AR54.10-P-0003RT
14	Connect STAR DIAGNOSIS and read fault memory	After disconnecting ground line on battery  Faults which may have been caused by disconnecting wires or by a simulation must be erased in the fault memory after completing the work.	
15	Install lower engine compartment paneling	Model 164 Model 251	AR61.20-P-1105GZ AR61.20-P-1105RT
16	Screw cap onto coolant expansion reservoir (1)		

**Engine cooling, general**

Number	Designation		Engine	Engine
			272	273
BA20.00-P-1001-02E	Coolant drain plug to crankcase	Nm	12	12

**Nm Coolant pump, coolant thermostat**

Number	Designation	Stage	Nm	Engine 276
BA20.10-P-1008-01AA	Drain screw on coolant pump	Stage 1	Nm	6
		Stage 2	└°	90

**Mixture ratio for coolant**

Number	Designation	ENGINE all	
BF20.00-P-1001-04A	Mixture ratio for coolant	Antifreeze/water up to -37°C	50/50
		up to -45°C	55/45
	Specifications for service products	Sheet	<a href="#">BB00.40-P-0310-01A</a>
		Sheet	<a href="#">BB00.40-P-0325-00A</a>

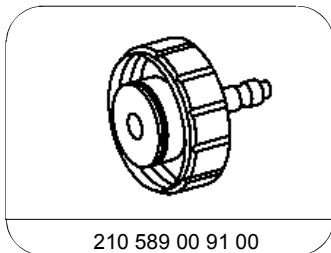

Check cap

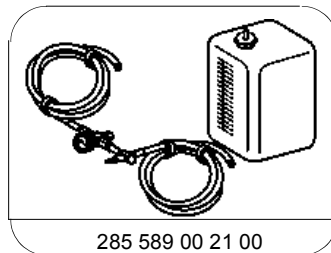

Vacuum-type cooling system filler