

AR32.20-P-0200GZ	Remove/install front spring	9.1.06
------------------	-----------------------------	--------

MODEL 164.1 except CODE (489) Airmatic (air suspension with level adjustment and adaptive damping system ADS)

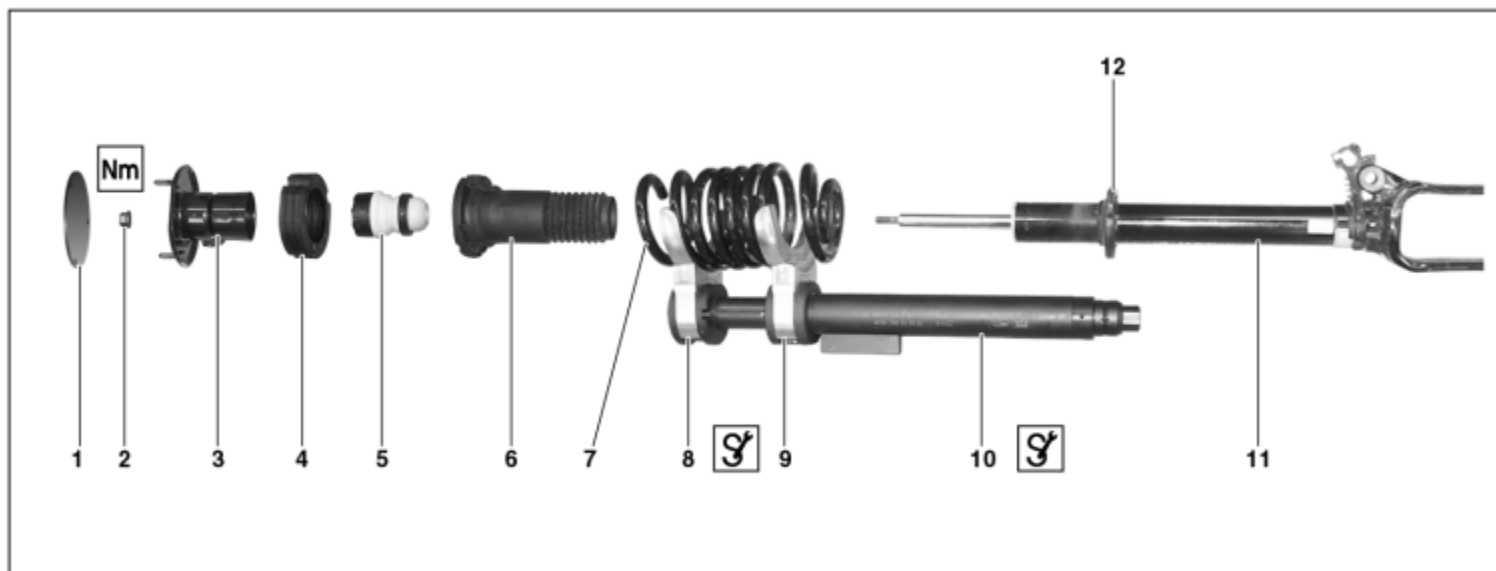











P32.25-2144-08



1 Cap
2 Securing nuts
3 Top spring retainer
4 Spring seat

5 Stop damper
6 Bellows
7 Spring
8 Clamping plate

9 Clamping plate
10 Tensioning device
11 Shock absorber

☒	Removing		
⚠ Danger!	Risk of death caused by vehicle slipping or toppling off of the lifting platform.	Align vehicle between the columns of the lifting platform and position the four support plates at the lifting platform support points specified by the vehicle manufacturer.	AS00.00-Z-0010-01A
⚠ Danger!	Risk of injury caused by pinching or crushing when working on springs or	Use only approved tensioning devices; shield off hazard area if necessary.	AS00.00-Z-0001-01A

	spring bodies that are under load	Inspect special tools for damage and proper operation (visual inspection). Wear protective gloves.	
	Notes on self-locking nuts and bolts	All models	AH00.00-N-0001-01A
1	Remove front suspension strut		AR32.25-P-1017GZ
	Disassemble/assemble		
2	Clamp tensioning device (10) in vise and insert clamping plate (8, 9)	 Tensioning device	203 589 01 31 00
		 Tensioning plates	169 589 02 63 00
3	Insert suspension strut into tensioning device (10)	 When positioning the strut, attempt to get the maximum possible number of spring coils (7) in the spring clamp.	
4	Clamp spring (7) until the upper spring cup (3) is relieved of load.		
5	Remove cap (1)		
6	Undo fastening nut (2) and remove shock absorber (11)	 Counterhold piston rod with socket wrench.	
			BA32.25-P-1003-01G
		 Socket wrench	164 589 00 10 00
7	Remove bellows (6) and stop damper (5)		
8	Release tensioning device (10) and remove spring (7) with upper spring cup (3) and spring seat (4)		
	Checking		
9	Inspect shock absorber (11)	 Check shock absorber (11) for leaks. A thin film of oil on the shock absorber (11) is acceptable. Replace shock absorber (11) if necessary.	AR32.25-P-0121A

10	Check bellows (6), stop damper (5) and spring seat (4) for signs of wear	i Replace any components with oil contamination, cracks or deformation.	
11	Assemble in the reverse order	i Assemble suspension strut such that the upper spring cup (3) is correctly assembled and positioned on the suspension strut.	
	Install		
12	Install front suspension strut		AR32.25-P-1017GZ
13.1	Check headlamp adjustment and correct if necessary	i After installing new parts.	
	Check and correct headlamp setting		AP82.10-P-8260GZ

Nm Front axle shock absorber

Number	Designation	Model 164.1/8	
BA32.25-P-1003-01G	Nut to piston rod	Nm	30

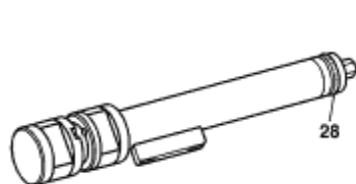

203 589 01 31 00
Tensioning device

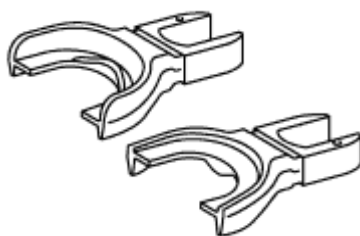

169 589 02 63 00
Tensioning plates

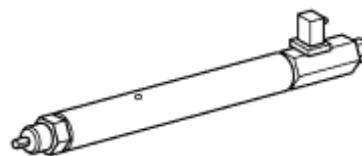

164 589 00 10 00
Socket wrench